

VIKING PUMP

A Unit of IDEX Corporation

Viking® Mag Drive Pumps

*Sealless Mag Drive Pumps For Crucial
Liquid Containment Applications*

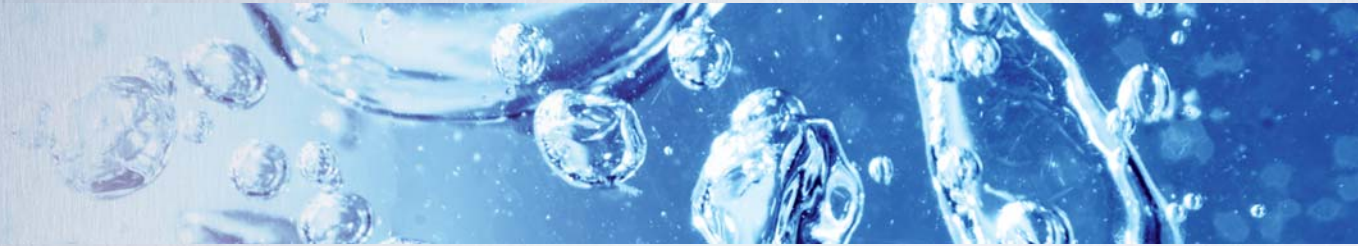

VIKING MAG DRIVE®

- Eliminates pump seal maintenance
- Highest level of liquid containment available
- Metric or U.S. Design

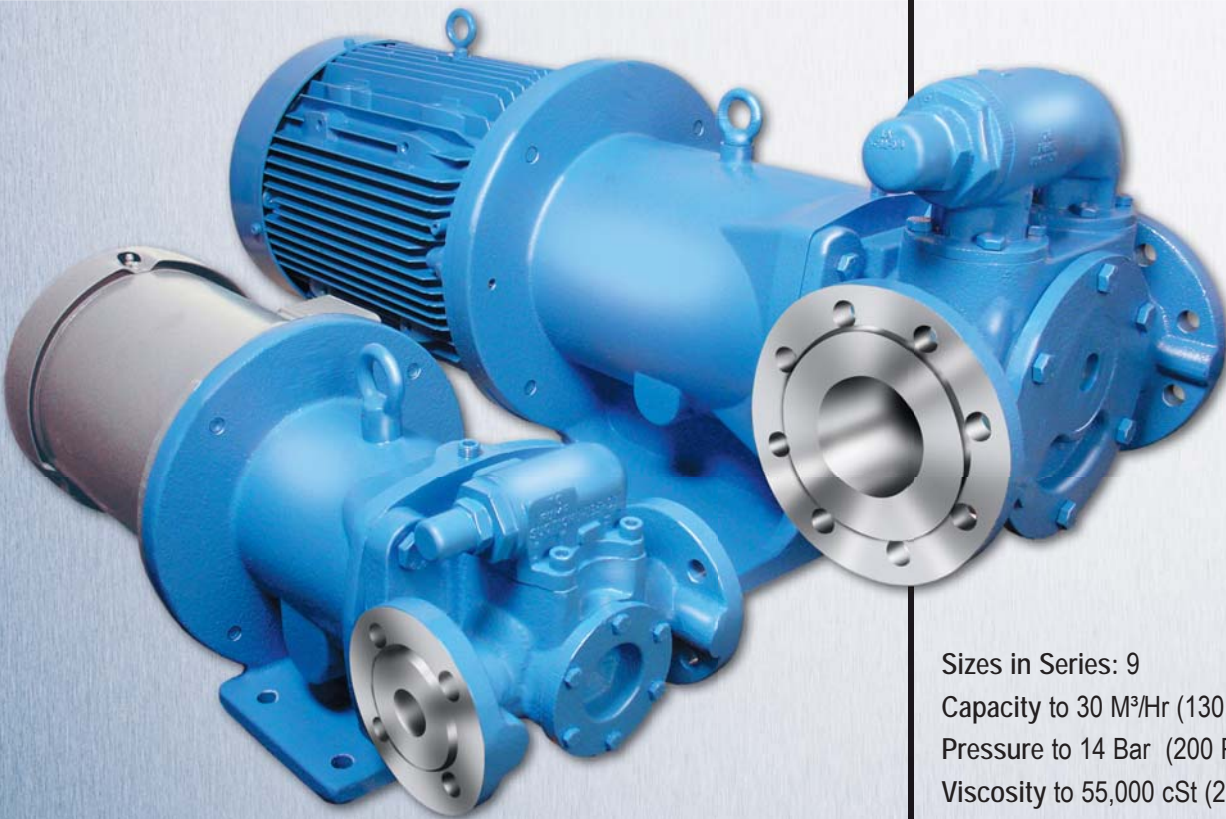

Sizes in Series: 9

Capacity to 30 M³/Hr (130 GPM)

Pressure to 14 Bar (200 PSI)

Viscosity to 55,000 cSt (250,000 SSU)

Temperature -51°C to 260°C (-60°F to 500°F)

IDEX
CORPORATION

Viking® Advantages

Performance

- No packing or mechanical seals means no seal failure or replacement
- Easily handles both high and low viscosity fluids
- Reduce material loss, contamination and general housekeeping
- Simple design, easy to maintain
- Proven reliability, 100 years of experience

Technology

- Proven sealless design
- Short-term, dry-run capabilities for easy line clearing or emptying tanks without damaging pump
- Viking developed the 1st commercially available internal gear mag drive pump

Productivity

- Highest level of liquid containment available
- Eliminates downtime due to seal replacement
- Local inventory and support worldwide
- Bi-directional pump design for enhanced application flexibility
- Lower life cycle cost

Available Options

- Ports available in ANSI or DIN Flange
- Special construction options for bushings, shaft, & clearances available
- Other options include: power load monitor, temperature probe, and low flow detector
- Gauge ports

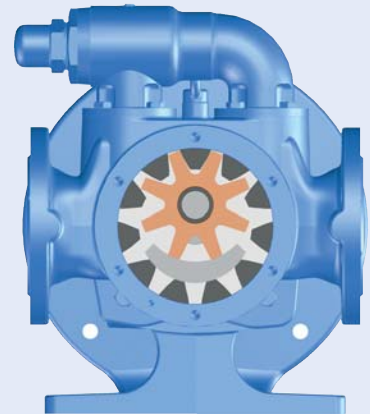

The 855 Series Mag Drive uses the Internal Gear pumping principle

The Internal Gear pumping principle offers many advantages over both centrifugal pumps and other types of positive displacement pumps, including:

- High efficiency for low life-cycle cost
- 14 Bar (200 PSI) capability
- Smooth, non-pulsating, low-shear flow
- Self priming capability
- Suction lift capability
- Capacity proportional to speed
- Excellent metering repeatability
- Able to handle thin or thick liquids in a broad temperature range
- Bi-directional pump design
- Easy-to-pipe, straight-through porting

Performance Envelope

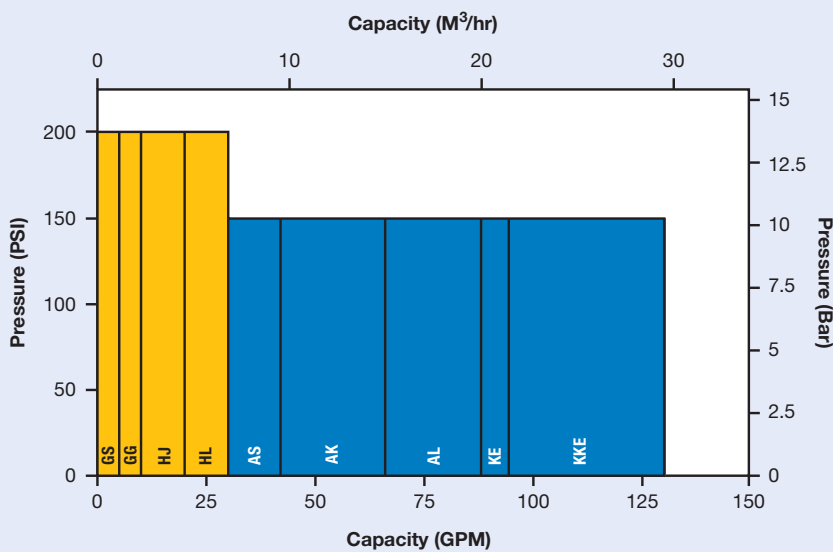

Note: Capacities to 38 M³/hr (167 gpm) and/or pressures to 14 bar (200 psi) may be allowable with engineering review.

Hard-to-Seal Liquids



Shaft seal leakage is the number one cause of pump downtime and maintenance. Shaft seals wear faster when liquid, air and heat combine at the seal to cause chemical reactions, like:

- **Crystallization** (e.g. isocyanates). Abrasive crystals cause premature wear.
- **Sticking** (e.g. adhesives, epoxy resins, paints). Seal faces bond when pump stops, and fails at startup.
- **Varnishing** (e.g. petroleum products). Layer builds up on seal faces causing separation.

Typical Applications:

- Isocyanates
- Sodium Hydroxide
- Adhesives
- Epoxy Resins

Hazardous & Reactive Liquids



Shaft seals can allow liquids and vapors out, causing hazardous exposure, and can allow air in, causing unwanted chemical reactions. Traditional sealed pumps, including those that require flushing, quenching and barrier fluids, are subject to the same failures as single seals, with the additional cost and maintenance headaches of the associated equipment (pumps, pressure vessel, tubing/piping, filters, etc.). When the costs of environmental controls are considered, the Viking Mag Drive 855 Series is a cost-effective alternative.

Typical Applications:

- Volatile Organic Chemicals
- Hazardous Chemicals
- LPG and Ammonia
- Reactive Chemicals

24/7 Operations



Unplanned downtime to fix a leaky seal is unacceptable in facilities with continuous processes, like refineries, chemical plants and paper mills. Even when pumping “safe” liquids, seals are subject to mechanical problems like loss of compression, misalignment of pump and driver, improper seal installation, shaft deflection causing off-center faces, suction lift (vacuum) causing face separation, and many others. If you can't afford pump downtime, the Viking Mag Drive 855 Series offers exceptional up-time reliability through its robust, sealless design.

Typical Applications:

- Refineries
- Chemical and Polymer Plants
- Paper Mills
- Pipelines

Model Number Key

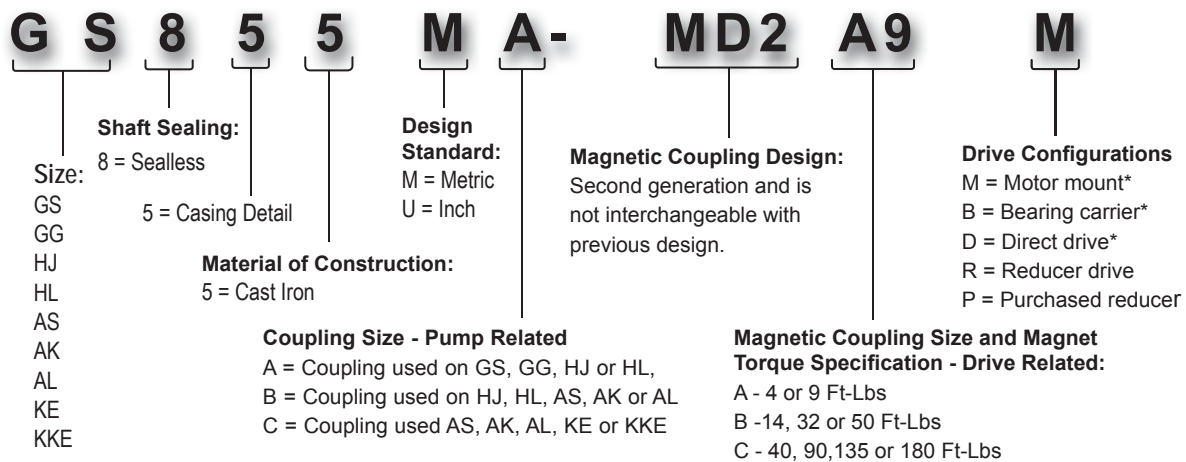

*To assure the proper bracket and outer magnet is supplied on an M unit (Motor Mounted Drive), the motor frame (NEMA or IEC) must be specified when ordering. For B and D drives, specify the shaft style (inch or metric) that will be required for proper mounting on the unit.

Viking® Benefits

ADVANCED DURABILITY

■ Proven Design

Pump has only two moving parts proven in thousands of tough applications around the world. Simple design minimizes service requirements while providing unmatched durability and reliability.

■ Unique Rotor Positioning System

Thrust washers on both sides of front bushing lock rotor position regardless of application variables. Fixed axial position permits short-term dry-run and bi-directional operation.

■ Heavy Duty Bearings and Bushings

Proven, rugged pump design equipped with heavy-duty bearings and bushings. Provides enhanced shaft support extending pump and in-canister bushing life.

■ Effective Cooling System

Simple, internal channels ensure continuous liquid flow throughout canister removing heat generated by magnetic eddy currents. Protects temperature sensitive liquids and pump

■ Metric or U.S. Design

855 Series are equipped with DIN 2501 or ANSI B16.5 compatible flanges, IEC-B5 or NEMA-C compatible motor flanges and metric or U.S. dimensional bearing carrier shafts. Provides quick, easy installation and compatibility with local standards worldwide.

■ Flanged Ports

In-line ported flanges are standard, offering 90° rotation to vertical or horizontal positions. Provides better sealing reliability than threaded ports.

■ Mounting Configurations

Close-couples to motors up to 15 kW (20 HP) to simplify mounting and eliminates a shaft coupling, guard and shaft alignment. An optional bearing carrier (shown) allows coupling to a speed reducer, gear motor, or standard motor. Provides mounting configuration matched to your application.

■ No Special Tools Required

Jack bolts for coupling disassembly are standard with the pump. Simplifies maintenance and reduces planned downtime.

■ Innovative Magnet Design

Inner magnet is encapsulated in a laser welded stainless steel canister. One-piece design extends pump life and eliminates maintenance.

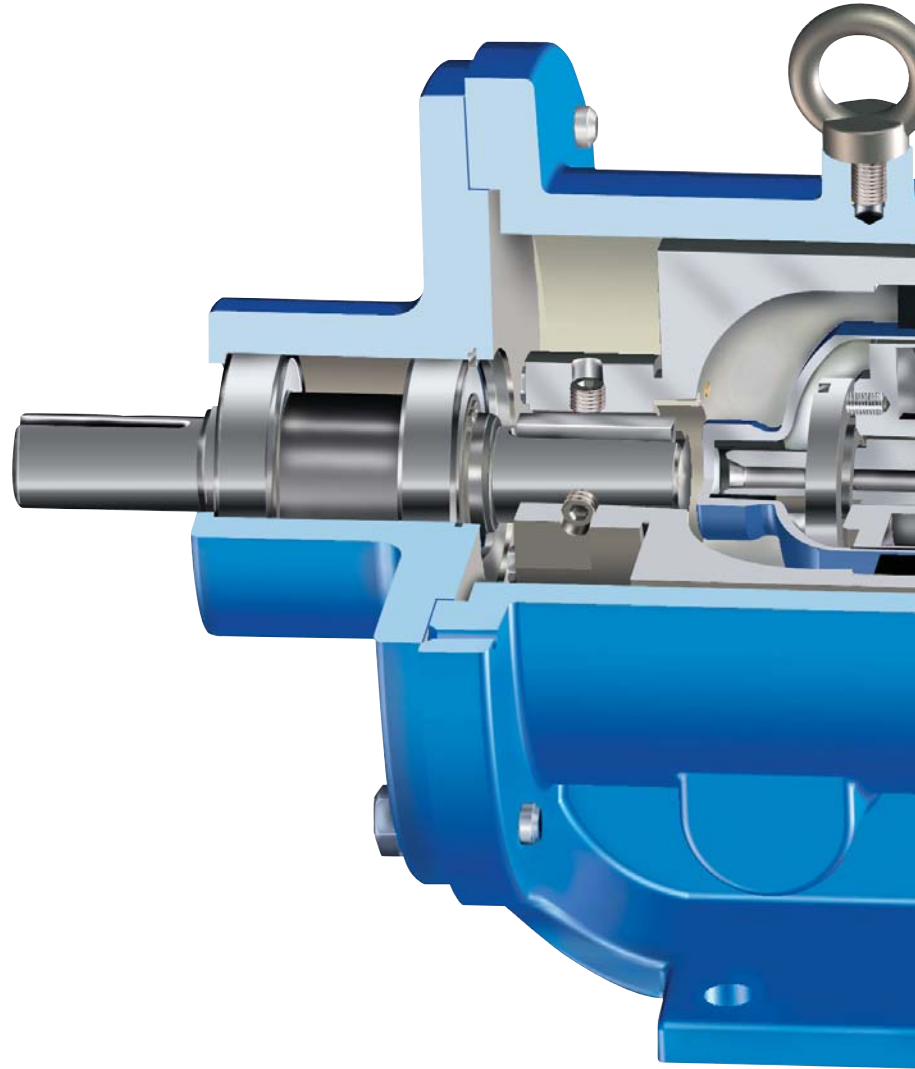

■ Lifting Lug Included

Allows for easier pump handling when installing, removing or disassembling pump. Simplifies installation.

EASY INSTALLATION

■ Externally Adjustable Relief Valve

Relief valve (not shown) can be adjusted while in service when process conditions change. Provides maximum process up-time.

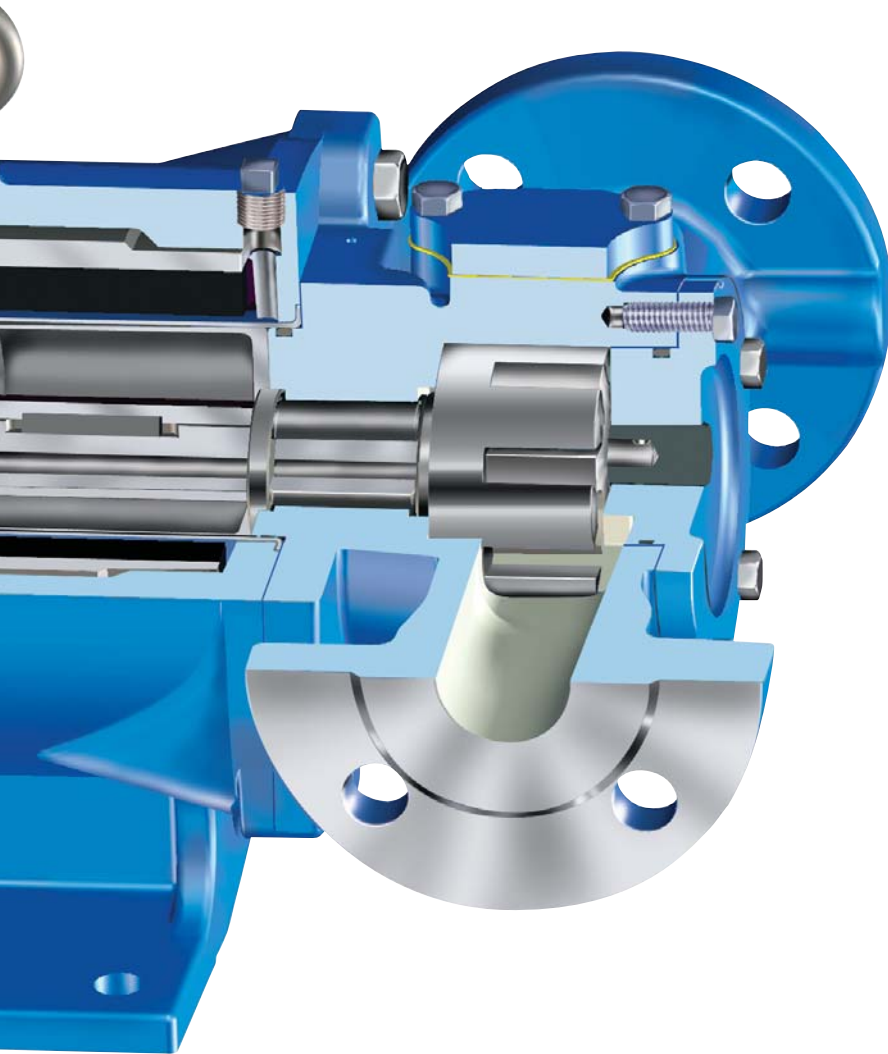

■ Relief Valve Standard

Pumps come with an adjustable internal pressure relief valve on standard design. Protects pump from over-pressure.

■ Short-Term Dry-Run Capability

Short-term run dry is possible due to state of the art design and magnet technology. Protects the pump during priming and accidental empty-tank situations.

■ Bi-Directional Pump Design

Bi-directional pumping design eliminates cost of second pump and piping needed for loading or unloading or line stripping. Provides application flexibility and reduces system costs.

■ Adjustable End Clearance

Allows the pump to be adjusted for different viscosities and temperatures if process changes, increasing productivity. Single point adjustment maintains and maximizes pump efficiency, extending life.

■ Dual Thrust Control Washers

Positive control of rotor position for more accurate flow also reduces pump wear. Provides lower life cycle costs and improves process control capability.

■ Optimized Efficiency

Proven, optimized gear and pump geometry maximizes overall efficiency. Reduces product operating cost, providing a lower total cost of ownership.

■ Higher Pressure Capabilities

Thrust control, enhanced shaft support and a wide selection of materials permits higher pressure [14 BAR (200PSI)] capabilities. Permits single pump standardization for multiple liquids and applications.

■ Easy Drain and Flush

Pump chamber drain and a canister drain facilitate flushing for easy liquid removal between batch operations or maintenance. Reduces planned downtime for maintenance and housekeeping.

Materials of Construction & Specifications

Viking Mag Drive Series 855 Construction

Component	Standard Construction	Options
Casing, Head, Magnetic Coupling Bracket	Cast Iron	
Shaft	Steel	Hardened Steel
Canister	316 Stainless Steel	
Head Shims	316 Stainless Steel	
Idler	Iron	PPS (complete)
Rotor (GS, GG)	Cast Iron	Steel
Rotor (HJ, HL, AS, AK, AL, KE, KKE)	Ductile Iron	
O-Rings	Buna-N	Viton®, PTFE (Derivative) Encapsulated
Bushings	Carbon Graphite	Hardened Cast Iron
Thrust Washers	Hardened Cast Iron	
Magnets (outer magnets nickel plated, inner magnets sealed in stainless steel canister)	Neodymium Iron Boron	Samarium Cobalt

Viton® is a registered trademark of DuPont Performance Elastomers.

Viking Mag Drive Series 855 Specifications

Pump Model	Standard Port Size		Capacity at Maximum Rated Speed			Maximum Hydrostatic Pressure		④ Maximum Differential Pressure		⑤ Maximum Recommended Temperature		Approximate Shipping Weight	
	mm	in.	M³/Hr.	GPM	RPM	BAR	PSI	BAR	PSI	Deg. C	Deg. F	Kg.	Lb.
GS855	① 25	③ 1	1.1	5	1750	27	400	14	200	107	225	27	60
GG855			2.2	10								32	70
HJ855	① 40	③ 1.5	4.5	20	1750	27	400	14	200	107	225	32	70
HL855			6.8	30								27	60
AS855**	② 65	③ 3	9.5	42	1450	20	300	10	150	107	225	32	70
AK855**			15.0	66								88	195
AL855**			20.0	88								195	195
KE855***	② 80	③ 3	21.3	94	1150	20	300	10	150	107	225	93	205
KKE855***			29.5	130								93	205

** Speeds up to 1750 RPM and corresponding capacities may be allowable with engineering review.

*** Speeds up to 1450 RPM and corresponding capacities may be allowable with engineering review.

① = Metric design standard, with DIN 2501 PN 16/25/40 Raised-Face Flanges

② = Metric design standard, with DIN 2501 PN 25/40 Raised-Face Flanges

③ = US design standard, with ANSI B16.5 125# Class Flat-Faced Flanges

④ = Sizes AS - KKE - pressures to 14 Bar (200 PSI) and viscosities to 55,000 cSt (250,000 SSU) may be allowable with engineering review.

⑤ = Maximum Temperature (standard Neodymium Iron Boron Magnets) 107° C (225° F) Maximum Temperature (optional Samarium Cobalt Magnets) 260° C (500° F).

Magnetic Coupling Specifications****

Magnetic Coupling Size	Models	Torque Rating Options Ft - Lbs.	Close-Coupled to Motor		Long-Coupled Bearing Carrier
			IEC B-5 Flange	NEMA-C Flange	
MD2A	GS855, GG855, HL855, HJ855	4, 9	80/90, 100/112	56C, 143/145TC, 182/184TC	Metric of US Shaft
MD2B	HL855, HJ855, AS855, AK855, AL855	14, 32, 50	100/112, 132	182/184TC, 213/215TC, 254/256TC	Metric of US Shaft
MD2C	AS855, AK855, AL855, KE855, KKE855	40, 90, 135, 180	132, 160, 180	254/256TC, 284/286TC	Metric of US Shaft

**** Selecting a magnetic coupling requires information from the specific pump curve to determine the horsepower and coupling torque requirement, adjusted for operating temperature. Contact your local Viking Pump distributor for pump selection assistance.

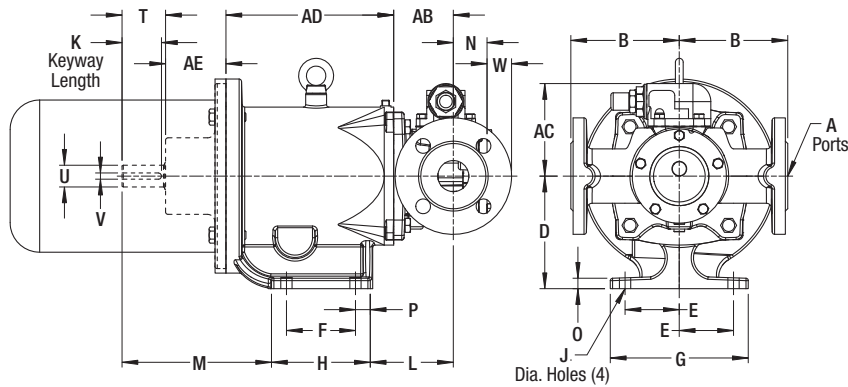

Dimensions for "M" models (Metric-standard pumps)

Coupling	Pump Model	A (mm)	B (mm)	L (mm)	N (mm)	W (mm)	AB (mm)	AC (mm)
A	GS 855 M	25 ¹	102	95	49.0	8.3	65	119
	GG 855 M							
A or B	HJ 855 M	40 ¹	140	107	43.0	32.0	77	119
	HL 855 M							
B	AS 855 M	65 ²	150	119	67.3	28.0	92	206
	AK 855 M							
	AL 855 M							
C	AS 855 M	65 ²	150	138	67.3	28.0	111	206
	AK 855 M							
	AL 855 M							
	KE 855 M	80 ²	170	143	64.0	35.6	114.3	223
	KKE 855 M							

1 DIN 2501-Compatible PN 16/25/40 Raised Face Flanges

2 DIN 2501-Compatible PN 25/40 Raised Face Flanges

3 Bearing Carrier (shown in dashed line) or IEC B-5 Flange Motor Mount

Coupling	Drive ³	D (mm)	E (mm)	F (mm)	G (mm)	H (mm)	J (mm)	K (mm)	M (mm)	O (mm)	P (mm)	T (mm)	U (mm)	V (mm)	AD (mm)	AE (mm)
A	Bearing Carrier	130	69.9	88.9	178	145.0	14.5	46	141	13.5	19	56.0	28	8	182	77.7
	80/90	130	69.9	88.9	178	145.0	14.5	—	—	13.5	19	—	—	—	182	—
	100/112	130	69.9	88.9	178	145.0	14.5	—	—	13.5	19	—	—	—	182	—
B	Bearing Carrier	145	69.9	88.9	178	127.5	14.5	46	191	13.5	19	56.0	28	8	216	77.7
	100/112	145	69.9	88.9	178	127.5	14.5	—	—	13.5	19	—	—	—	216	—
	132	170	69.9	108.0	178	146.3	14.5	—	—	13.5	19	—	—	—	236	—
C	Bearing Carrier	170	95.0	146.0	254	216.6	24.0	63	283	19.3	35.6	103.4	48	14	284	139.7
	132	170	95.0	146.0	254	216.6	24.0	—	—	19.3	35.6	—	—	—	284	—
	160/180	203	120.0	165.0	305	235.0	24.0	—	—	19.3	35	—	—	—	314	—

Dimensions for "U" models (U.S.-standard pumps)

Coupling	Pump Model	A ⁴ (in)	B (in)	L (in)	N (in)	W (in)	AB (in)	AC (in)
A	GS 855 U	1	4	3.74	1.94	0.32	2.56	4.68
	GG 855 U							
A or B	HJ 855 U	1.5	5.5	4.21	1.69	1.26	3.03	4.68
	HL 855 U							
B	AS 855 U	3	5.91	4.69	2.65	1.10	3.62	8.12
	AK 855 U							
	AL 855 U							
C	AS 855 U	3	5.91	5.44	2.65	1.10	4.37	8.12
	AK 855 U							
	AL 855 U							
	KE 855 U		6.69	5.57	2.53	1.40	4.50	8.79
	KKE 855 U							

4 ANSI 616.5-Compatible 125# Class Flat Face Flanges

5 Bearing Carrier (shown in dashed line) or NEMA-C Flange Motor Mount

Coupling	Drive ⁵	D (in)	E (in)	F (in)	G (in)	H (in)	J (in)	K (in)	M (in)	O (in)	P (in)	T (in)	U (in)	V (in)	AD (in)	AE (in)
A	Bearing Carrier	4.50	2.75	4.00	7.00	5.71	0.56	1.88	5.00	0.53	0.76	2.06	0.875	0.19	7.34	2.50
	56C, 145TC	4.50	2.75	4.00	7.00	5.71	0.56	—	—	0.53	0.76	—	—	—	7.34	—
	182/184TC	5.12	2.75	4.25	7.00	6.12	0.56	—	—	0.53	0.76	—	—	—	7.60	—
B	Bearing Carrier	5.50	2.75	4.88	7.00	6.41	0.56	2.12	7.60	0.53	0.78	2.72	1.125	0.25	9.30	2.87
	182/184TC	5.50	2.75	4.25	7.00	5.78	0.56	—	—	0.53	0.78	—	—	—	8.92	—
	213/215TC	5.50	2.75	4.88	7.00	6.41	0.56	—	—	0.53	0.78	—	—	—	9.30	—
	254/256TC	6.50	2.75	5.50	7.00	7.03	0.56	—	—	0.53	0.78	—	—	—	9.92	—
C	Bearing Carrier	6.69	3.75	5.75	10.00	8.53	0.945	2.50	11.14	0.76	1.40	4.07	1.875	0.50	11.20	5.50
	213 thru 256TC	6.69	3.75	5.75	10.00	8.53	0.945	—	—	0.76	1.40	—	—	—	11.95	—
	284/286TC	6.69	3.75	5.75	10.00	8.53	0.945	—	—	0.76	1.40	—	—	—	12.49	—



A Unit of IDEX Corporation

Leader in Positive Displacement Pumping Solutions.

Innovation and Experience

Viking Pump has been a pump industry leader and innovator since its founding in 1911. We continue to build on our ever growing experience delivering innovative new pumping solutions, including custom designs, to thousands of customers who use Viking® pumps in some of the world's toughest applications.

Broad Performance Range

Capacity:

0.5 to 360 M³/Hr (0.1 to 1,600 GPM)

Pressure:

0 to 172 Bar (0 to 2,500 PSI)

Temperature:

-84°C to 370°C (-120°F to 700°F)

Viscosity:

0.5 to 1,000,000 cSt (28 to 4,500,000 SSU)

Ultimate in Sealing Solutions

Viking's offering of packing, component mechanical seals, cartridge seals and sealless Mag Drive technology provides the best choices for sealing flexibility needed to provide your application a customized sealing solution every time - saving you money, time and unplanned downtime.

Material Options Matched to Application

Viking's dedicated iron and alloys foundries provide pump construction materials from cast iron to Alloy C. Application-specific materials of construction extend a pump's life significantly, while reducing maintenance and unplanned downtime, enabling increased production and a better bottom line.

Liquid Integrity Protection

Viking has developed multiple positive displacement pump principles to protect shear-sensitive liquids, and low-shear options to prevent damage to fibers, polymers and solids. Full-jacketing options provide precise temperature control throughout the pump. The Viking Mag Drive® and other seal options prevent fluid contact with air, assuring liquid integrity.

Local Applications and Engineering Support

Over 245 Authorized Viking Pump Distributors in 68 countries provide local application support and service. They are backed by Viking Application Engineers and Viking Region Managers strategically located around the world.

Quality Manufacturing

Viking uses ISO9001-2008, Six-Sigma, and Lean/Kaizen in its worldwide manufacturing and assembly processes to remove waste, reduce development costs, and deliver superior products. Dedicated Viking foundries and manufacturing facilities utilize state-of-the-art CNC equipment to assure unmatched quality is built into every pump.

Custom Designed Solutions

Viking has provided custom designed pumps to end-users and OEMs since its first pump in 1911, when Viking invented the gear-within-a-gear pumping principle to remove water from a rock quarry. Today, enabled by Viking's engineering staff, extensive applications experience and in-house foundries, more than 20% of Viking's sales are new designs or pump designs derived from one of our 40,000 active configurations. Whether you are an end-user or an OEM, Viking can provide custom designed pumping solutions to meet your specific needs.



For more information, contact your local Authorized Viking Pump Distributor or contact Viking at:

VIKING PUMP, INC.

A Unit of IDEX Corporation
406 State Street
Cedar Falls, Iowa 50613-0008 U.S.A.
Telephone: (319) 266-1741
Fax: (319) 273-8157
E-mail: info.viking@idexcorp.com
Web site: www.vikingpump.com

CANADA

Windsor, Ontario
Phone: (519) 256-5438
Fax: (519) 256-5070
www.vikingpumpcanada.com

EUROPE

Shannon, Ireland
Phone: +353 (61) 471933
Fax: +353 (61) 475046
www.vikingpumpeurope.co.uk

LATIN AMERICA

Mexico D.F., C.P.
Phone: +52 (55) 5255-1357
Fax: +52 (55) 5255-1356

Brazil - Sao Paulo

Phone: +55 (19) 3871-3500
Fax: +55 (19) 3871-6400

ASIA-PACIFIC GROUP

Singapore
Phone: +65-6763-6633
Fax: +65-6764-4020
www.idexfmt-asia.com

China - Shanghai

Phone: +86-21-5241-5599
Fax: +86-21-5241-8339
www.idexfmt-asia.com

China - Beijing

Phone: +86-10-6566-9090
Fax: +86-10-6567-5152
www.idexfmt-asia.com

China - Guangzhou

Phone: +86-20-3886-6156
Fax: +86-20-3886-2776
www.idexfmt-asia.com

India - Mumbai

Phone: +91-22-66976634
Fax: +91-9820334270
www.idexfmt-asia.com

China - Suzhou

Phone: +86-512-62833000
Fax: +86-512-62833010
www.idexfmt-asia.com

ASIA-PACIFIC GROUP

China - Chengdu
Phone: +86-28-86767458
Fax: +86-28-86767468
www.idexfmt-asia.com

China - Suzhou

Phone: +86-512-62833000
Fax: +86-512-62833010
www.idexfmt-asia.com

Korea - Seoul

Phone: +82-2-501-3302
Fax: +82-2-556-0788
www.idexfmt-asia.com

Australia & New Zealand

Phone: +61 2 4577 4534
Fax: +61 2 4577 5987
www.idexfmt-asia.com

MIDDLE EAST

IDEX Middle East FZE
Dubai, UAE
Phone: +971-4-299-1095/1097
Fax: +971-4-299-1069
www.idexfmt-asia.com



OFFICIAL DISTRIBUTORS FOR:

**VIKING
PUMP**

A Unit of IDEX Corporation

Viking Gear Pumps

Liquiflo 

Liquiflo Gear Pumps



FINISH THOMPSON INC.

Finish Thompson Drum & Centrifugal Pumps



Codip Air Operated PTFE Diaphragm Pumps

MICROPUMP

Micropump Gear Pumps

HNPM

HNP Mikrosysteme

HNP Gear Pumps

WANNER
Hydra-Cell
Seal-less Pump Technology

Hydra-Cell High Pressure Diaphragm Pumps



M Pumps, Centrifugal,
Turbine and Vane Pumps

ISMATEC

Ismatec Peristaltic Pumps

 **FLUID** METERING, INC.

Fluid Metering Piston Pumps

