

# POWER MONITOR

## Model M20

Affordable protection for any FTI pump including UC, DB and SP Series mag drives.



### Features:

- Provides accurate shaft power measurement
- Instantaneously shuts down pump when a change in shaft power is sensed
- Easy to install
- Autoset makes set up quick and easy
- Monitors supply power from line voltage
- Electronically locks parameters
- Digital readout of HP, % HP, kW, % kW, volts and amps
- Programmable relay configurations
- Four levels of protection (pre-alarm minimum & maximum power; alarm minimum & maximum power)
- Just three models cover all motor voltages up to 690 VAC
- Operates at 50 or 60 Hz
- Programmable analog signal proportionate to the motor's shaft power
- Carries independent testing lab approvals; CE

### How it works

The M20 utilizes a unique algorithm to measure normal work load and then calculates and sets a shut-down sequence when an increase or decrease in shaft power is detected outside the determined parameters. Pump shut-down takes place before dry-running damage can occur.

### Benefits

- More accurate than amp monitors and motor input power monitors.
- Pump curves express load data in shaft power, not motor input power.
- The significant losses of the motor are removed to improve accuracy and reliability.
- Protection parameters are set against the actual working load.
- The power displayed by the meter is the actual power being used by the pump.

### Uses:

- Dry running – Protects pumps with PTFE, silicon carbide or ceramic bushings if no liquid is present.
- Dead heading – Prevents operating the pump with a closed discharge valve or clogged filter.
- Excess power – Prevents failures due to foreign objects being sucked into the pump, changes in system piping, or changes in fluid characteristics such as viscosity or specific gravity.
- SP Series – Delay feature ensures pump is primed and operating.



FINISH THOMPSON INC.

## SPECIFICATIONS

### The complete M20 requires a transducer.

Selecting an M20 power monitor:

- Select a part number based on the operating voltage and phase for the motor
- Monitors work at either 50 or 60 Hz.

Voltage	Part Number
100-240 volt, 1 & 3 phase	J103768-1
380-500 volt, 3 phase	J103767-1
525-690 volt, 3 phase	106431

Selecting a transducer:

- Determine the full load amp draw of the motor at the installed voltage.
- Price for M20 includes transducer

Full Load Amps	Part Number
0.40 to 10.0	J103769
10.1 to 25.0	J103770
25.1 to 50	J103771

## M20 WIRING DIAGRAM

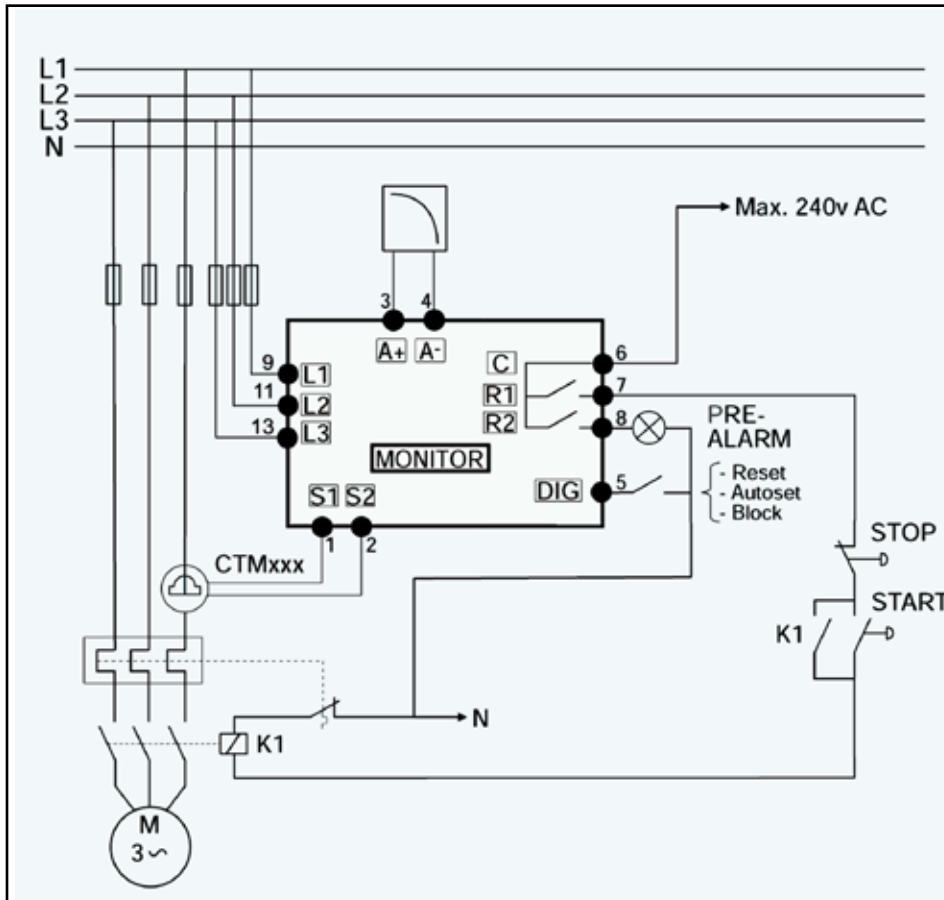

Sample Installation



**FINISH THOMPSON INC.**

921 Greengarden Road • Erie, PA 16501-1591 U.S.A.  
Ph 814-455-4478 • Fax 814-455-8518  
Email [fti@finishthompson.com](mailto:fti@finishthompson.com) • [www.finishthompson.com](http://www.finishthompson.com)

Sales 1-800-934-9384  
Literature ID No. FT08-1034A

**OFFICIAL UK DISTRIBUTOR - MICHAEL SMITH ENGINEERS LTD**  
freephone: 0800 316 7891      web: [www.michael-smith-engineers.co.uk](http://www.michael-smith-engineers.co.uk)