

31F SEALED 31F-MC MAG-DRIVE

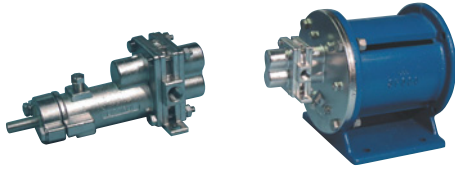

**3 - SERIES
ROTOGEAR®
GEAR PUMP**



Sealed

Close Coupled:
Sealed or Mag-Drive

PERFORMANCE CURVES

1 CPS Fluid (Water)

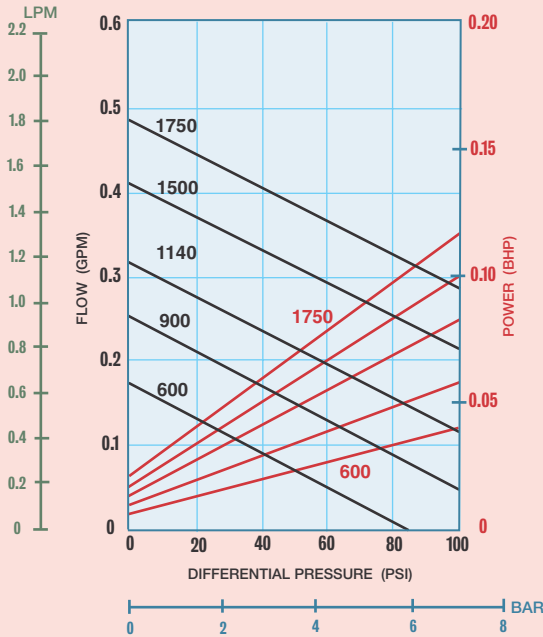

100 CPS Fluid (Oil)

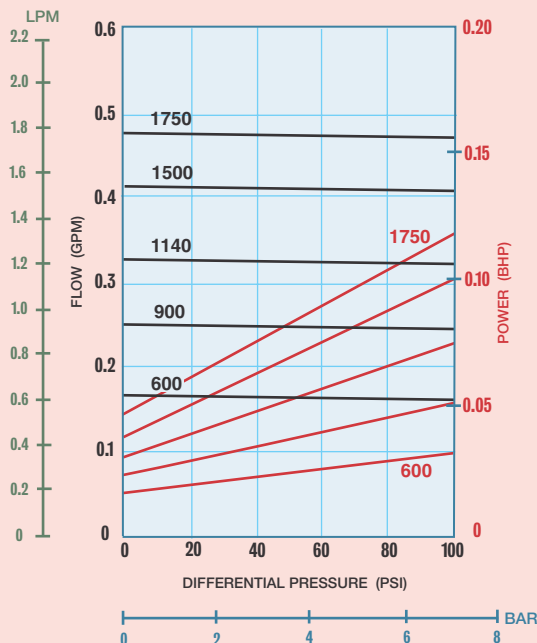

PORT SIZE	1/4" NPT/BSPT or 1/2" FLG
MAX FLOW	0.5 GPM; 1.9 LPM
MAX DIFFERENTIAL PRESSURE	100 PSI; 7 BAR
MAX DISCHARGE PRESSURE	300 PSI; 20.7 BAR
MAX TEMPERATURE	500°F; 260°C
MIN TEMPERATURE	-40°F; -40°C
MAX VISCOSITY	100,000* CPS
NPSHR @ 1750 RPM	3 FT; 0.9 M
LIFT (DRY)	0.5 FT; 0.15 M
WEIGHT (without motor)	
SEALED	2.5 LBS; 1.1 KGS
MAG-DRIVE	31 LBS; 14 KGS

* Higher viscosities possible. Contact factory.

Dimensional Data (inches)

Long-Coupled: 31F Sealed

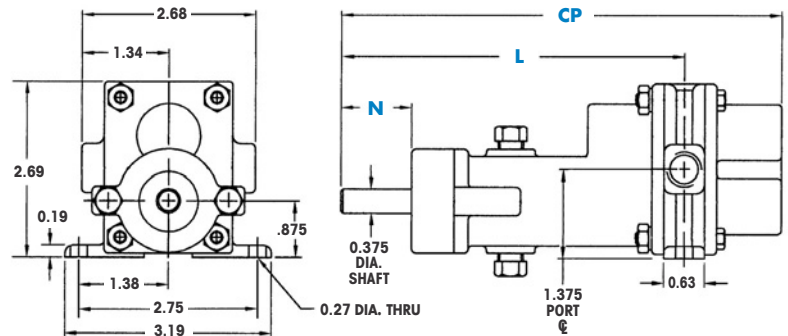

DIMENSION	SEAL CONFIGURATIONS		
	PACKING SINGLE MECHANICAL SEAL DOUBLE MECHANICAL SEAL	EXTERNAL MECHANICAL SEAL	LIP SEAL
CP(1)	6.94	7.66	6.94
N	0.81(2)	1.03	0.81
L	5.44	6.16	5.44

NOTES: (1) Add .312 inches for Bearing Flush Plug.
(2) Minimum dimension.

Dimensional Data (inches)

Close-Coupled: 31F-MC & 31F Sealed

