

CODIP

AIR OPERATED PTFE TUBULAR DIAPHRAGM PUMPS

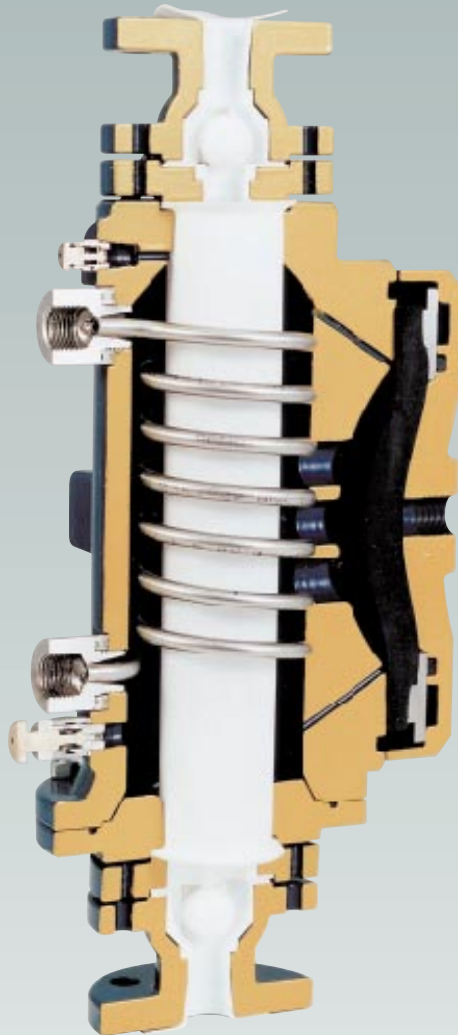

DOUBLE CONTAINMENT FOR MAXIMUM SAFETY



**EXPERIENCE AND RELIABILITY
IN HANDLING OF
CORROSIVE CHEMICALS**



Cert. N° 0011918-01

CODIP manufactures the only range of air-operated pumps with PTFE tubular diaphragm in the world; an engineering pedigree compared to the conventional PTFE diaphragm pumps.

They are successfully used for over twenty years in different segments of the fine chemical (CPI) and pharmaceutical industries for a very wide range of applications in which it may have an arduous duty: fluids of all types, viscous, abrasive, corrosive often at high temperatures, etc.

Engineered for maximised safe handling of the most aggressive chemical and abrasive applications, the CODIP hydraulically balanced tubular diaphragm (diatube) design eliminates concentrated areas of stress, the primary cause of diaphragm failures.

Conventional mechanically actuated double diaphragm and peristaltic pumps require frequent maintenance due to high stress points, while the CODIP's unique design cuts down the maintenance costs to a minimum because it combines the benefits of hydraulic actuation with the versatility of air operation.

Double containment is another important feature of the tubular diaphragm concept, which addresses the growing demand for sealless pumps and ensures zero leakage in the event of a diaphragm failure.

PUMP OPERATION

CODIP pumps operate without any mechanical linkage, electric motor or mechanical seal; an external automatic air valve directs air pressure to the backside of a flexible rubber diaphragm. An inert liquid transmits this pressure uniformly to the tubular diaphragm and through this to the process liquid.

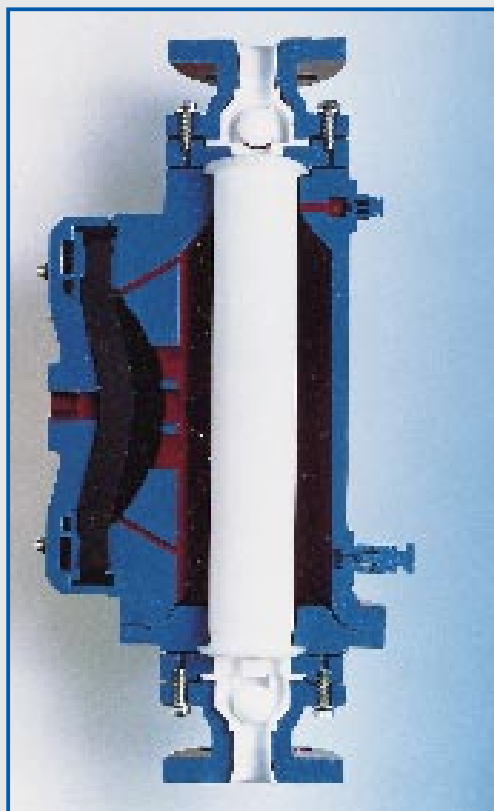

TECHNICAL FEATURES

- Pure (virgin) hydrostatically pressed PTFE wetted parts, fully guaranteed against permeation, for all corrosive chemicals and blends.
- 25 bar test pressure.
- - 20 °C up to 180 °C temperature range
- Optional Viton®, Hypalon®, EPDM or Neoprene construction is available for extremely abrasive and/or corrosive liquids.
- Dry self-priming, can run dry without damage.
- Dead heading without damage.
- Sealless double containment configuration prevents any exhausting of process fluid into the atmosphere.
- Optional electronic or electropneumatic leak detection system (IP55 or explosion proof zone 1 and zone 0).

- Unique elastomeric air membrane eliminating complex hydraulic systems.
- Completely external air distributor for easy access. Lubrication-free, non-freezing.
- Integrated stroke frequency controller independent of air pressure or discharge pressure
- Optional remote and/or metering control (pneumatic-electric-electropneumatic).

CONSTRUCTIONAL FEATURES

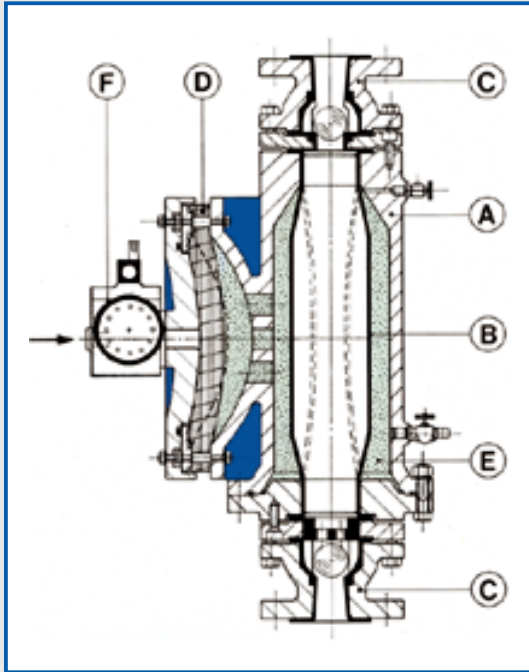

- A) 25 bar test pressure Aluminium alloy or ductile iron housing protected by an outer and inner coating of epoxy resins.
- B) Hydraulically balanced Tubular diaphragm (PTFE-Viton®, Hypalon®, EPDM, Neoprene), the very heart of the pumping system; it operates at the same internal and external pressure therefore minimising diaphragm stresses designed for extreme long continuous duty applications resulting in a life cycle normally well over 10.000 hours of maintenance-free service when put to service according to specification.
- C) Ball check valves (PTFE- Viton®, Hypalon®, EPDM, Neoprene) ; or PTFE "shuttles" valves for increased dry suction lifts (see "SH/DSL" range)

- D) Very solid flat air diaphragm (natural rubber, Neoprene, Silicone rubber, Viton/Neoprene, HNBR) is part of the secondary containment.
- E) Hydraulic inert liquid (water, glycol, glycerin, silicone oil or other compatible liquids on demand).
- F) Pneumatic air distributor: operated by filtered, clean and oil-free compressed air. All moving parts are cylindrical and all gaskets are of the self lubricated O-ring type. An integrated stroke frequency controller for adjusting the pump cycles is supplied within the standard pilot valve. Fitted with very efficient exhaust air silencers. Optionally available is a totalizing-predetermining impulse counter (batch controller) or remote control unit 3-15 psi (pneumatic actuator) transducers for 4-20 mA or other electrical signals can also be supplied.

PNEUMATIC AIR DISTRIBUTOR - FEATURES -

AIR VALVE	AIR PRESSURE		STROKE FREQUENCY (cycles/min)	AIR INLET (Ø)
	MIN.	MAX.		
SIMPLEX (RP 20/RP 60)	2,5 bar	10 bar	0-120	1/2" gas
DUPLEX (RP 60Dx/RP 150 Sx e Dx)	3 bar	10 bar	0-100	3/4" gas

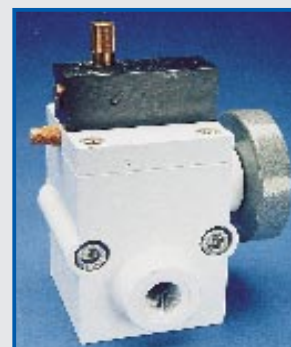

MATERIALS OF CONSTRUCTION

MODEL	PUMP BODY	INERT LIQUID	AIR DIAPHRAGM
RP 20	A/D	WG/GL/SO/PL/GLY/X	R/N/VN/S/HN
RP 60 simplex	A/D	WG/GL/SO/PL/GLY/X	R/N/VN/S/HN
RP 60 duplex	A/D	WG/GL/SO/PL/GLY/X	N/S/HN
RP 150 simplex	A	WG/GL/SO/PL/GLY/X	N/S/HN
RP 150 duplex	A	WG/GL/SO/PL/GLY/X	N/S/HN

WETTED PARTS			
	TUBULAR DIAPHRAGM	CHECK VALVES	BALLS
RP 20	P/E/V/N/F/S	P/E/V/N/F	P/G/E/V/F/C/SS
RP 60 simplex	P/E/V/N/F	P/E/V/N/F	P/G/E/V/F/C/SS
RP 60 duplex	P/E/V/N/F	P/E/V/N/F	P/G/E/V/F/C/SS
RP 150 simplex	P/E/V/N/F	P/E/V/N/F	P/G/E/V/N/F/
RP 150 duplex	P/E/V/N/F	P/E/V/N/F	P/G/E/V/N/F/

Meanings of abbreviations:

A = Aluminium alloy
 GL = Propylene Glycol
 GLY = Glycerin
 N = Neoprene
 HN = HNBR
 E = EPDM
 C = Ceramic

D = Ductile Iron
 SO = Silicone Oil
 X = others on demand
 S = Silicone rubber
 P = pure P.T.F.E.
 F = Hypalon®
 SS = 316 stainless steel

WG = Water and glycol (30%)
 PL = Liquid paraffin
 R = Natural rubber
 VN = Viton® backed neoprene
 G = Glass filled P.T.F.E.
 V = Viton®

SPECIAL ASSEMBLIES

PUMPS "SD" RANGE: suitable for processes containing solids that require all PTFE wetted parts. The PTFE tubular diaphragm type "SD", is specifically designed to handle solids containing liquids, and operates without spacers to allow maximum passage of suspended solids or crystals (max. concentration 50%) up to diameters of 7 mm (see the below table); abrasion and/or corrosion resistant check valves are, the glass filled PTFE seats and balls (other standard options for balls available are: ceramic or stainless steel AISI 316).

MAX. SIZES OF SOLIDS (mm)

Modello	RP 20	RP 60	RP 150
PTFE "SD" pumps	2÷2,5	4÷5	6÷7
Rubber pumps	3,5÷4	7	10÷11



PUMPS "SH" RANGE with PTFE "shuttle" check valves in order to achieve maximised suction lifts and to ensure an optimum sealing off the valves. The PTFE "shuttles", (different in shape for the discharge valve and suction), are specifically designed to give:

- Minimised lifting height to reduce the priming time, also effecting the efficiency of the pump
- Optimised sealing on the seats to maintain the priming
- Fluodynamically optimised shape to minimise friction losses.

The "SH" Series allow dry suction lift between 3,5 m (RP 20) and 6 m (RP 60 Dx), ensuring optimal efficiency of the pump due to the perfect sealing of the check valves in and minimising wear of PTFE seats and balls.

PUMPS "HC" RANGE with integrated stainless steel AISI 316 heat exchanger. Certain applications require the handled liquid to be kept within a certain range of temperature. This pump range is suitable for this duty without any form of electric tracing or other surface heating systems. In fact the SS coil is positioned inside to the pump body, fully immersed into the inert liquid concentric to the tubular diaphragm to heat the pumping liquid. The external connection is through two threaded 1/2" ports in the side of the pump body for steam, diathermic oil or water if you like. The air distributor is supplied with an SS AISI 316 spacer positioning it outside any form of insulation you may want to install around the pump. And also preventing it's overheating. Of course this pump range pumps can also be used to cool the handled fluid in order to come to a constant process liquid temperature.

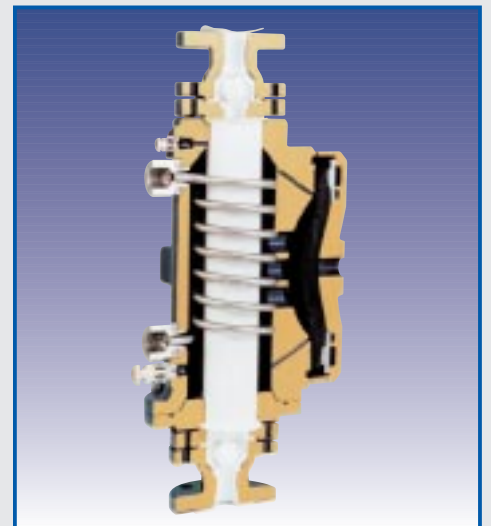

MODEL SELECTION AND SPECIFICATIONS

MODEL	FLOWRATE ⁽¹⁾ (l/min)	FLANGES ⁽²⁾ (mm)	SUCTION HEADS ⁽³⁾ (bar)	DISCHARGE HEADS (bar)
RP 20	20	25	0,35	10
RP 60	60	50	0,5	10
RP 60 Duplex	120	50+50	0,6	10
RP 150	150	80	0,4	10
RP 150 Duplex	300	80+80	0,5	10

NOTES:

- (1) The above mentioned capacities are based on 18°C water and a driving-air pressure of 3 bar, with 10 m.l.c. discharge head and 1 meter negative suction head. The effective flowrate of any given system depends on both the nature of the pumped fluid (viscosity-density-vapour pressure) and most important the layout of the suction piping (geometric pumped height-size-length volume and friction losses,etc.).
- (2) Flanges are normally DIN 2532 ND 10 or ANSI 150 lbs. Other standards can be supplied.
- (3) The above data are obtained under self-priming conditions with PTFE "shuttle" valves for the RP 20 model and for RP 60 Simplex and Duplex models, with standard PTFE ball check valves for RP 150 Simplex and Duplex models.
- (4) Duplex pumps are normally supplied without inlet and outlet manifolds. These manifolds can be supplied if required but normally it is more efficient to include them into the piping scope.

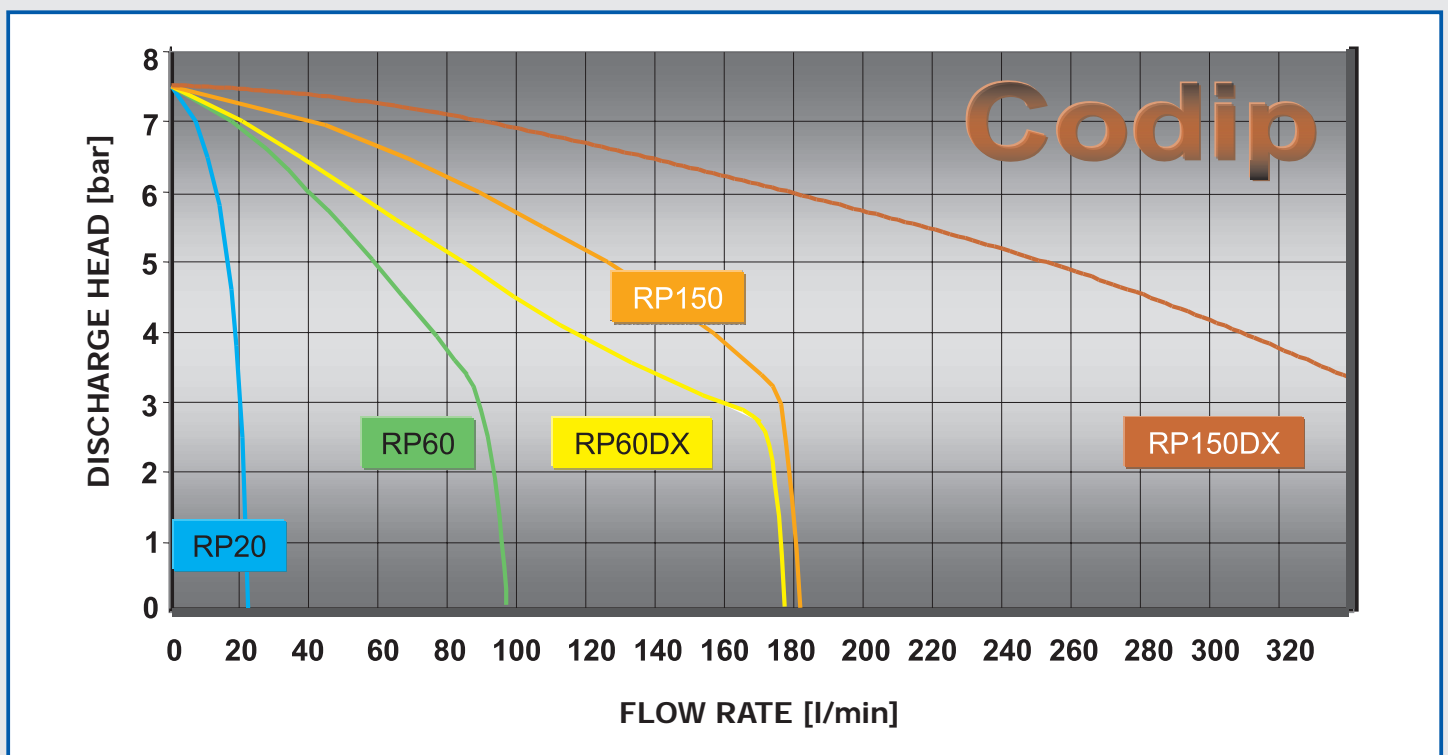

INSTALLATION NOTES

- (1) Install the pump as close as practically possible to the suction connection of. Two epoxy coated steel legs enable fixing to a pedestal. When the pump, installed above a liquid level, it is advisable to install a foot valve. Suction and discharge pipework has to be as short and straight as possible, the suction line has to be of a diameter that is at least equal to the nominal diameter of the pump. If the suction is line too long and/or too high, there is a risk of gas build-up (swan neck) and depriming. Also carefully calculate the NPSH available as it may affect the maximum obtainable flow.
- (2) The discharge piping should be as direct as possible. Long lengths of pipework may require the installation of pulsation damper, or only allow reduced capacities.
- (3) A pressure reducer **without an oiler** should be installed in the air supply line to limit the air pressure between 0,5 and 3 bar above the pumps total discharge head, with a minimum working pressure of 2,5 bar and a maximum pressure of 10 bar. Severe pipe-shock and excessive air consumption may occur when the driving air pressure exceeds the above values referred to the backpressure on the outlet side.
- (4) Install an air filter to protect the pressure regulator and air valve from pipe scale, etc.
- (5) Never use oil-lubricators, as oil in the driving air will damage the air-distributor.
- (6) Regulate the flowrate of the pump by adjusting the stroke frequency regulator on the pumps air distributor, or throttling the discharge valve. Never throttle the suction valve or reduce the air-pressure.

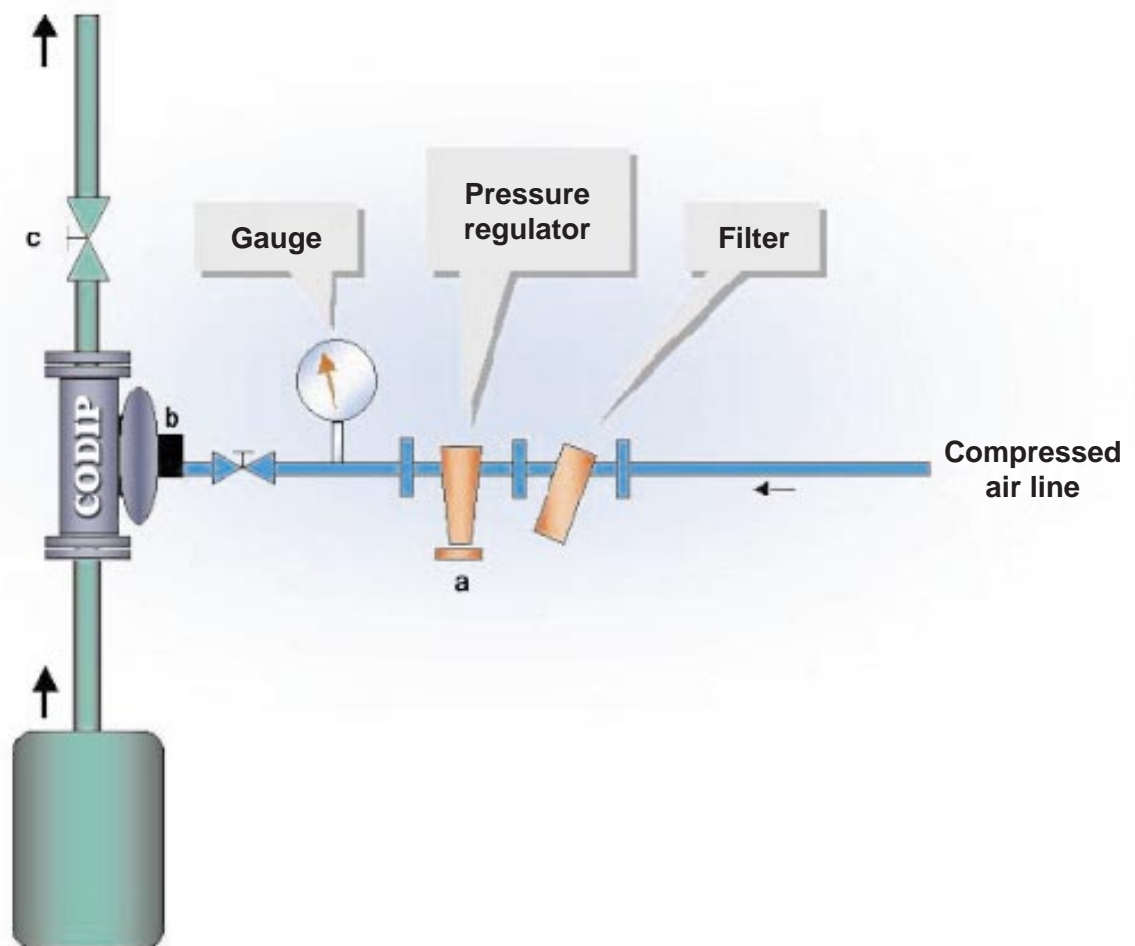

PERFORMANCE CURVES

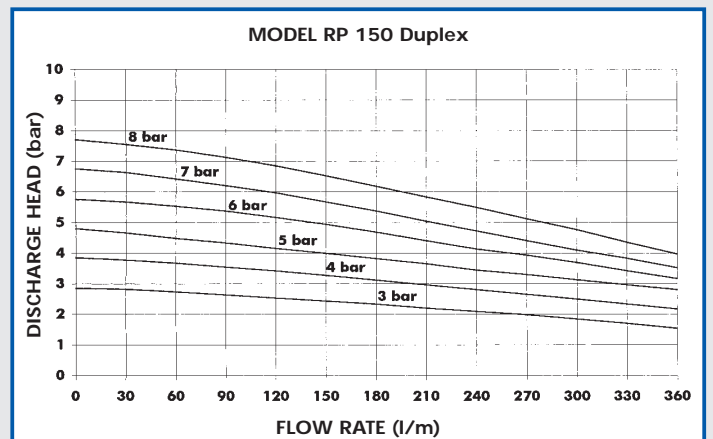
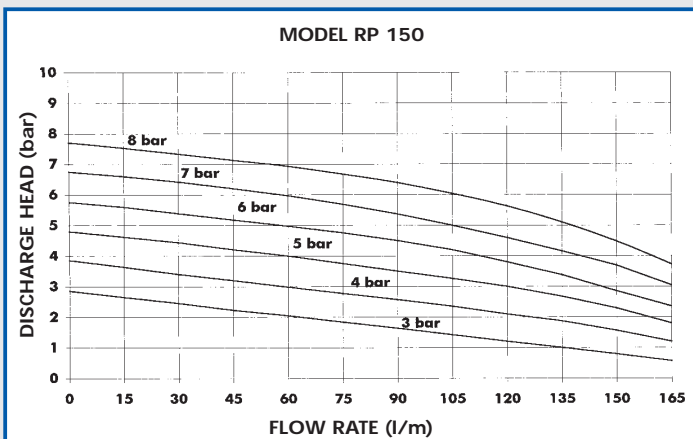
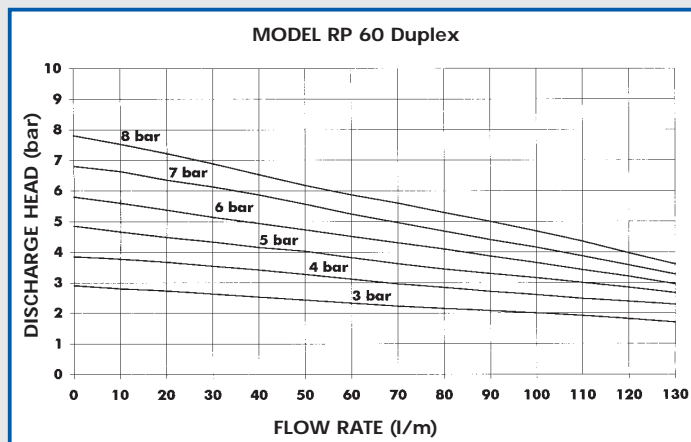
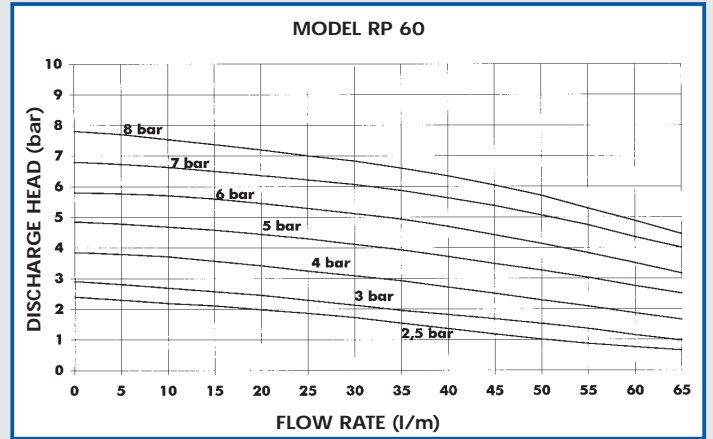
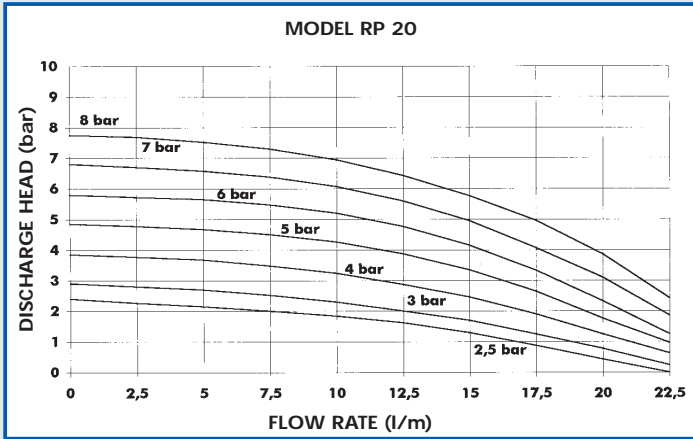

COMPRESSED AIR REQUIREMENTS

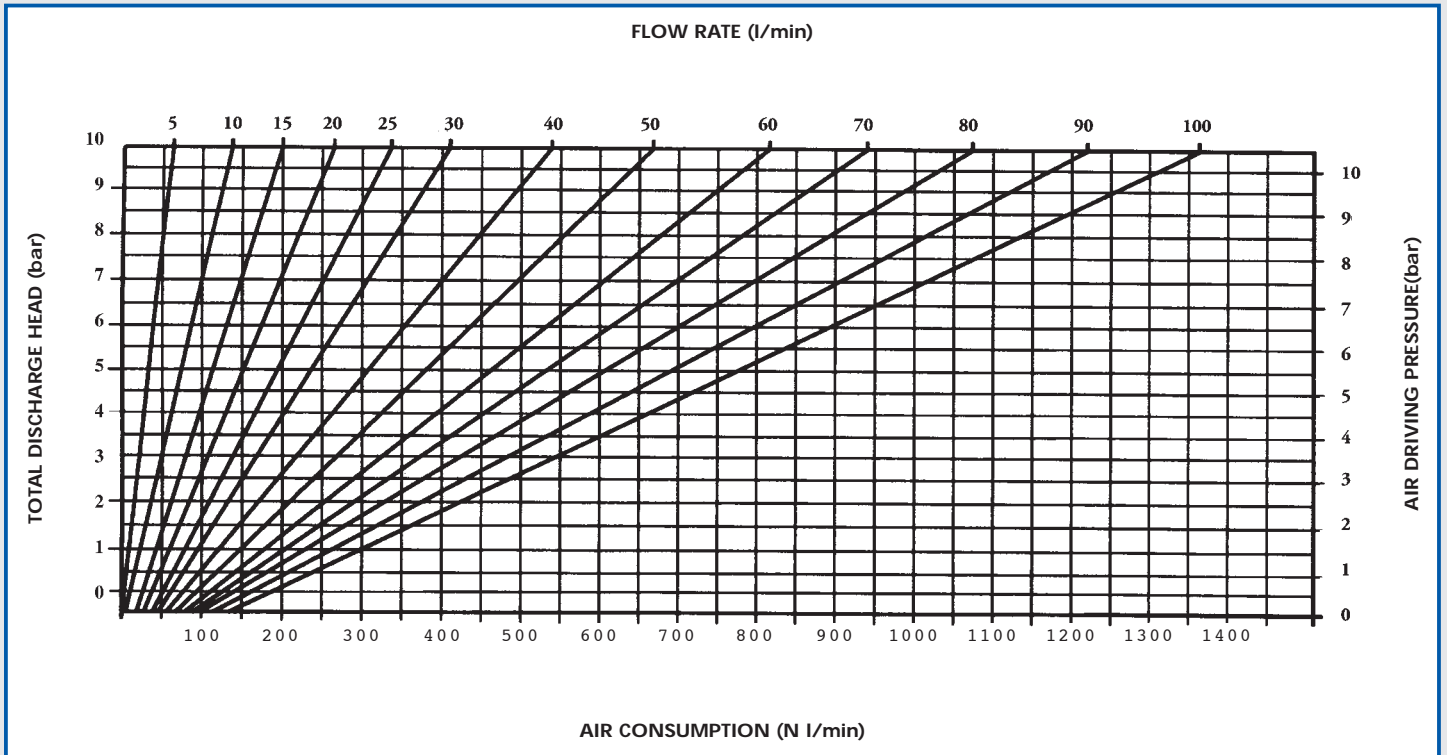

You can establish the driving air consumption by selecting the required air driving pressure on right-hand scale of the grid, from this point project a line horizontally to the left until it intersects with the desired capacity curve; the air consumption can be obtained by projecting a line vertically downward from this intersection point. For flows higher than 100 l/min, you can extrapolate this diagram.

DIMENSIONAL DATA (mm)

TIPO	RP 20	RP 60	RP 60 DUPLEX	RP 150	RP 150 DUPLEX
A	220	305	-	390	-
B	92	120	120	135	135
C	240	385	330	510	460
D1	470	650	650	940	940
D2	490	829	829	940	940
E1	200	315	315	460	460
E2	190	228	228	460	460
G	-	-	560	-	700
H	-	-	465	-	520
ØJ*	115	165	165	200	200
ØL	1/2" gas	1/2" gas	1/2" gas	3/4" gas	3/4" gas
R	130	200	200	230	230
S	70	95	95	120	120
ØT	17	20	20	20	20
V	130	155	155	450	450
W	180	275	275	315	315
X	25	50	50	50	50
Y	80	100	100	130	130
Z	50	80	80	80	80

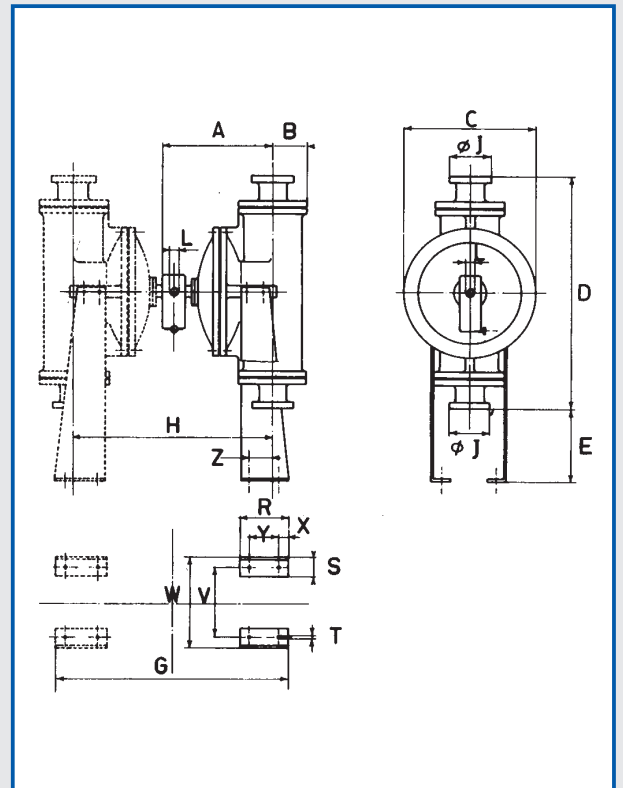

D1, E1: pumps in PTFE D2, E2: pumps in rubber

*Flanges DIN 2532 ND 10 or ANSI 150 lbs. (other standards on request)

REMOTE CONTROL FOR METERING APPLICATIONS

All models of the CODIP pumps can be fitted or retrofitted with our 3-15 psi remote control unit. The CODIP remote control unit is designed to adjust the stroke frequency and therewith the pump capacity.

The system operates with a 3-15 psi controller (pneumatic actuator) coupled to the standard air distributor.

The pneumatic actuator operates with 3-15 psi pressure modulation by means of a (tapered) conical pivot acting on the stroke frequency regulator inside the external air distributor.

The actual angle of actuators connection pivot determines the maximum value of frequency strokes; the standard range of modulation is 0-120 cycles/min for RP 20 and RP 60 Simplex models or 0-100 cycles/min for RP 150 Simplex and all duplex models.

The CODIP remote control unit can be connected to any type of electro-pneumatic transducer to convert an electrical signal (4-20 mA or other options) into a 3-15 psi pneumatic signal.



RP 60 with pneumatic actuator

ACCESSORIES

Leak detection system

The CODIP leak detection system is designed to constantly monitor the inert barrier liquid inside the CODIP pump. This may be necessary for safety or economical reasons. All CODIP pumps have a double containment shell that prevents any liquid pumped to come into the environment in case of a failure of the tubular diaphragm. Still you may want to know the presence of possibly high corrosive material in the inert barrier liquid, as the double safety barrier is no longer present in this case. For the same reason a failure of the air diaphragm has to be monitored. Another reason for monitoring the inert barrier liquid is that you can not accept a contamination of your process liquid by this inert barrier liquid. The CODIP leak detection system is extremely accurate and detects the slightest contamination of the inert barrier liquid and responds with an alarm signal.



RP 20 with titanium probe Eex d T5

This enables you to stop the pump and at the same time close a valve downstream of the pump to isolate the system and therefore prevent any possible contamination of your process.

These systems are available in either IP55 or explosion proof zone 1 or also zone 0

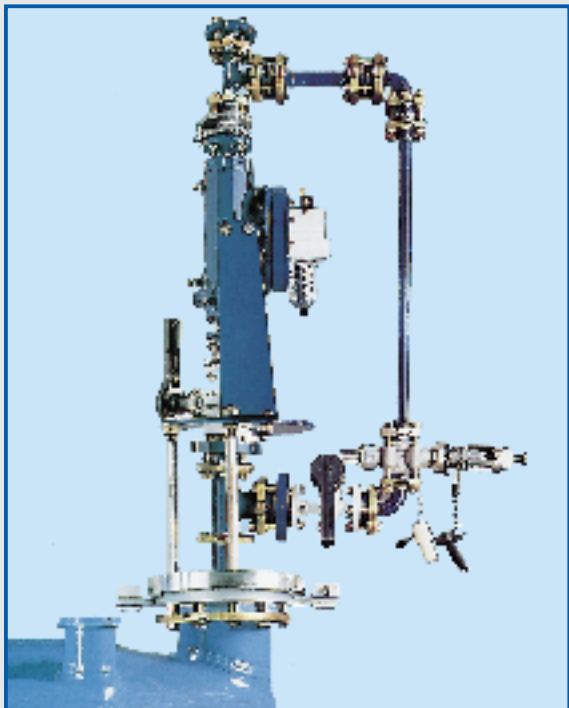

RP 20 on sampling system

MAIN APPLICATIONS

PTFE TUBULAR DIAPHRAGM PUMPS

Corrosive liquids, both hot and cold (sulphuric, HCl, HF, chlorinated compounds, liquid bromine, corrosive blends, etc.

Solvents, explosives (no electrical motor or controls required), hazardous or toxic liquids.

Unstable dispersions (PVDC, latex, etc.)

Ultra-pure liquids (no contamination or contact with atmosphere).

Pharmaceuticals as fermentation broth, antibiotics, vitamins (PTFE "SD" range pumps can be easily sterilised).

Paints varnishes, glues, inks, and resins due to the "non-sticking" properties of PTFE.

RUBBER TUBULAR DIAPHRAGM PUMPS

Liquids with abrasive solids in suspension such as ceramic slurries, crystalline products, high viscosity slurries, etc.



RP 60 PTFE



Factory:

Via Magistri Comacini, 4 - 22078 TURATE (CO) - ITALY

Sales & Marketing:

Viale Cadorna, 8 - 21052 BUSTO ARSIZIO (VA)
Tel.: +39/0331.679186 - Fax +39/0331.678341
E-mail: codipit@tin.it