



FLUID METERING, INC.

Valveless Metering Pumps & Dispensers



Solutions for...

Analytical
Laboratory
Process
Industrial
Instrumentation
OEM
Electronics
Food, Dairy, & Beverage
Agricultural & Pesticide
Spraying Systems
and more...

www.fmipump.com



"V" Variable Speed

Ideal For Automated Process Control

- Adjustable from 90 to 1800 strokes per minute for the **QV**, and 5 to 50 strokes per minute for the **QVG50**
- Q2V Ratio-Matic®** duplex for proportional metering using a single drive.
- Q2V Ratio-Matic®** duplex reduces pulsation by 50%
- Quick connect to V300 Controller (included).

*Best Value!
Most Versatile!*



QV/QVG50

QV
Motor Electrical: 1800 RPM, TENV.

Dimensions:
10" x 4 5/8" x 4 7/8" wide
(254 x 117 x 124 mm)

Shipping weight:
QV : 10 lb (4.5 kg)
V300: 5 lb (2.25 kg)

QVG50
Motor Electrical: 50 RPM, TENV.

Dimensions:
11" x 5" x 5 3/4" wide
(279 x 127 x 146 mm)

Shipping weight:
15 lb (6.75 kg)



RHV

Dimensions:
7 1/8" x 3" x 3" wide
(181 x 76 x 76 mm)

Shipping weight :
7 lb (3.15 kg)
V300: 5 lb (2.25 kg)

Electrical:
1800 RPM, TENV.

Drive + Pump Head = Complete Pump
Example: QVG50 + Q3CKC =

QV/QVG50/Q2V PDM (Includes V300)

MAX. Flow/Pressure				PDM	Piston Code	Price V300
ML/MIN	GAL/HR	PSIG	BAR			
1.25	.019	100	6.90	QVG50	RH00	
2.50	.039				RH0	
4.00	.063				Q0	
5.00	.079				RH1	
16.00	.252				Q1	
36.00	.568	Q2				
64.00	.998	25	1.72	Q3		
45	.71	100	6.90	QV	RH00	
90	1.4				RH0	
144	2.2				Q0	
180	2.8				RH1	
576*	9.1				Q1	
1296*	20.4	50	3.45	Q2		
2304*	35.9	25	1.72	Q3		



Drive Options
Dial Indicator (pg.20) Part Number: - Q485 Price:
Mounting Base (pg.12) Part Number: -MB Price:

*See Page 27 for General Specification notes

Call Us. We Have The Answers.

"RHV" Low Flow (0-180 ml/min max)

- No Valves to clog, hang up or service.
- Ceramic and PVDF standard wetted materials - Tefzel available.
- One moving part - piston.
- Accuracy of better than $\pm 1\%$ = Drift Free Operation.
- Drift-free flow ranges up to 180 ml/min, pressures from -10 to 100 psig.
- Easy grip flow control ring graduated in 450 divisions.
- Instant adjustment of flow while running.
- Adjustable from 90 to 1800 strokes per minute.
- Quick connect to V300 Controller (included).

RHV Pumps (Includes V300)

MAX. Flow/Pressure			Complete Pump	Wetted Parts	MAX. Temp	Price V300
ML/MIN	PSIG	BAR				
45	100	6.90	RHV00SKY	316 SS/PVDF/Carbon	140° F	
90			RHV0CKC			
180			RHV1CKC			
45			RHV00CTC	Ceramic / PVDF	212° F	
90			RHV0CTC			
180			RHV1CTC			
45	RHV00CTC					
90	RHV0CTC					
180	RHV1CTC					



"V" Variable Speed

Variable Flow Rate to 2300 ml/min



New

"V300" Automatic Rate Control/System

QV, QVG50, RHV and Q2V Pump Drive Modules

- Selectable 4-20 mA, 0-5 VDC, & 0-10 VDC input for automatic control.
- Membrane Switches for manual Flow Rate Settings and Start / Stop functions.
- Start, Stop & Reverse Flow while maintaining flow settings.
- Large 3 Digit LCD Flow Display.
- Universal Power Input accepts 100-240 VAC 50/60 Hz
- Rugged, anodized aluminum enclosure designed for both bench-top & wall mounting

Dimensions: 7 1/4" x 5 1/8" x 6 1/4" wide
182 mm x 128 x 159 mm



V300



Selectable 4-20 mA, 0-5 VDC, & 0-10 VDC input for automatic control. QV, QVG50, RHV & Q2V Pump Drive Modules.



Digital LCD Flow Display

PHM (PUMP HEAD MODULE)

Piston Size Code	Materials of Construction								
	CKC	CKY	CSC	CSY	SAN	SKY	SSY	STY	CTC
RH00									
RH0									
RH1									
Q0									
Q1									
Q2									
Q3									
Wetted Parts	Ceramic PVDF	Ceramic PVDF Carbon	Ceramic 316 SS	Ceramic 316 SS Carbon	Ceramic Teflon	316 SS PVDF Carbon	316 SS Carbon	316 SS Tefzel Carbon	Ceramic Tefzel
MAX.Temp	212° F	212° F	350° F	350° F	350° F	140° F	140° F	140° F	212° F
Options	(add Option Code & cost to Pump Module for complete price and part number)								
LF (pg.19)	N/C	N/C				N/C		N/C	N/C
W (pg.18)									
WT (pg.18)									
TC (pg.18)									
R479 (Pg.20)									
S ("Q" Only)									

RATIO:MATIC[®]

Proportional Dual Head Pump Drive Module



Q2V

Dimensions :
15" x 4 7/8" x 5 1/8" wide
(381 x 124 x 130 mm)
Shipping weight:
15 lb (6.75 kg)

*See page 28 "Pump Head Materials Configuration" for additional information.





"IVSP" Industrial Variable Speed Pump



New

- Flow Rates 0 to 2300 mL/min ±1%
- FMI's Patented CeramPump® Valveless Piston Design - One Moving Part in fluid path.
- Rugged, 1/4 HP, 3 phase High Torque Motor, ideal for viscous fluids.
- Space-Saving, DIN Mount Controller ideal for process control panels
- Local Keyboard & Remote Control
- Remote Speed Control: 0-20 mA, 4-20 mA, 0-10 VDC
- Multi-function I/O connector for forward, reverse, jog, emergency stop, & reset
- Complete System includes drive motor, pump head, variable speed controller, & cables.
- All electronic components



IVSP

Dimensions:
17 3/4" x 6 7/8" x 8 1/2" wide
(451 x 175 x 216mm)

Shipping weight:
43 lb (19.35 kg)

Electrical:
Controller:
Input 115 VAC, 1Ø, 50/60 Hz.
Output: 230 VAC, 3Ø 50/60 Hz

Speed adjustment
0 to 20 mA
4 to 20 mA
0 to 10 VDC

Motor:
230 VAC, 3Ø, 50/60 Hz.
Variable Speed, 1800 RPM max.

"X" Hazardous-Duty

QDX PDM (PUMP DRIVE MODULE)

MAX. Flow/Pressure			PDM	Piston Code	Drive Price
ML/MIN	PSIG	BAR			
43.13	100	6.90	QDX	RH00	
86.25					
138					
172.50					
552*					
1242*					
2208*	25	1.72		Q3	



Drive Options
Dial Indicator (pg. 20)
Part Number: - Q485
Price:

*See Page 27 for General Specification

PHM (PUMP HEAD MODULE)

Piston Size Code	Materials of Construction								
	CKC	CKY	CSC	CSY	SAN	SKY	SSY	STY	CTC
RH00									
RH0									
RH1									
Q0									
Q1									
Q2									
Q3									
Wetted Parts	Ceramic PVDF	Ceramic PVDF Carbon	Ceramic 316 SS	Ceramic 316 SS Carbon	Ceramic Teflon	316 SS PVDF Carbon	316 SS Carbon	316 SS Tefzel Carbon	Ceramic Tefzel
MAX.Temp	212° F	212° F	350° F	350° F	350° F	140° F	140° F	140° F	212° F
Options	(add Option Code & cost to Pump Module for complete price and part number)								
LF (pg.19)	N/C	N/C				N/C		N/C	N/C
W (pg.18)									
WT (pg.18)									
TC (pg.18)									
R479 (Pg.20)									
S ("Q" Only)									

*See page 28 "Pump Head Materials Configuration" for additional information.



QDX

Fixed Speed
The QDX High Flow Hazardous-Duty Class I, Group D; Class II, Group E, F, G

Dimensions:
17 3/4" x 6 7/8" x 8 1/2" wide
(451 x 175 x 216mm)

Shipping weight:
43 lb (19.35 kg)

Electrical:
115/230 VAC, 60 Hz, 1Ø, 1/3 hp, ball bearing UL listed motor, 1725 RPM, pigtail leads for conduit connection. Motor is totally enclosed fan cooled. 6.6 amps @ 115 VAC and 3.3 amps @ 230 VAC.





Programmable Variable Displacement

“VMP” Variable Speed Pump System

For Dispensing or Pulseless “Smoothflow” Applications

New

- Independently control both stroke rate and displacement volume
- Forward, Reverse, Suck-back, & Quick Prime all adjustable
- Up to 100 customer designed programs let you change setups on the fly for different applications
- Touch Screen Interface (TSI) provides intuitive setup of all fluid control parameters and communicates with up to 16 pump drives simultaneously
- RS232 and RS485 interface enables simultaneous computer or PLC control of up to 128 pump modules
- FMI's Patented CeramPump® No-Valve Design



VMP TRI Pulseless “Smoothflo”

3 Phase Pump System

Is a pump drive module with three pump heads driven as a single unit out-of-phase resulting in a pulseless flow output. Automatic control of displacement and speed are easily programmed by use of our TSI Touch Screen Interface or by remote from PLC or computer.

VMP TRI pumps offer 3 different pump head sizes to provide pulseless flows from 0.1ml/min up to 1500ml/min. Ideal for spray and coating applications where pulsing can't be tolerated.

VMP TRI

Dimensions:
8.96" x 6.75" x 7.56"
(228 x 172 x 192 mm)

Shipping weight :
7 lbs



VMP OEM Electronic Variable Displacement & Variable Speed Dispense System

Is a precision dispense pump drive offering automatic control of displacement and speed using 3 different pump head sizes dispense volumes of 0.01 to 0.320 ml/disp , 0.05 to 0.720ml/disp or 0.10 to 1.28 ml/disp @ dispense speeds from 1 to 300 dispenses/min are achievable. Units are easily programmed by our TSI Touch Screen Interface or by remote from PLC or computer. These units are ideal for production setups that are used for multiple products of differing volumes.

VMP OEM

Dimensions:
8.97" x 3.0" x 4.44"
(228 x 76 x 113 mm)

Shipping weight :
4 lbs



TSI Touch Screen Interface

Provides quick and easy programming of VMP products and can control up to 16 individual VMP Pump drives. It is capable of programming volume, speed, dwell, number of dispenses and provides up to 100 customer designed programs /pump system

TSI





“PiP” Precision Dispensers

For Pipetting, Syringing and Diluting



PiP

Dimensions:
5" x 5" x 4" wide
(127 x 127 x 102mm)
Shipping weight:
5 lb (2.25 kg)
Electrical:
115 VAC, 60 Hz, 1Ø, .08 amps,
150, 300, 600 RPM with 3 prong
power cord.

- Ideal for repetitive and volumetric dispensing of acids, solvents and aqueous solutions.
- Features FMI's unique low dead-volume pump heads, and synchronous motor drives
- Can act as a single shot dispenser using the hand/foot switch or as a single metering pump in the continuous mode.
- Using a combination of forward and reverse modes, dilutions can easily be accomplished.

PiP Pumps micro π-petter®

MAX. Dispense Rates	Complete Pump Assembly	Price
Microliters / Revolution		
0 - 25 µl	PiP00SKY	
0 - 50 µl	PiP0CKC	
0 - 100 µl	PiP1CKC	



Pump Options
Low Dead-Volume Pump Head (pg 19)
Part Number: -LF
Price:



CE

IDS2000

IDS 2000 shown with the Quick Run Module

Dimensions:
11.4" x 5.2" x 4.3"
(290 x 132 x 109 mm)

Shipping weight: 10 lb (4.5 kg)

Electrical: Power Input: 24-32 VDC, 2+ amps Drive Speed (RPM). Field selectable presets from 10 to 1200 RPM Analog 0-5 VDC input control from 6 - 1200 RPM Protection: Internal 2.5 Amp replaceable plug in fuse. Connection: 6 ft. shielded cable with connector.

“IDS” Industrial Dispensers

For Industrial Process Environments

- No Valves to clog, hang up or service.
- Drift-Free accuracy better than ± 1 %.
- Dispense or continuous metering.
- Fixed or variable speed.
- PLC compatible.
- Dispense volume: 0.002 to 1.28 cc/shot up to 7 shots/dispense at 0.5% precision.
- Rugged, stainless steel, splash-proof wall mount design.
- Quick Run Module ready-to-use interface for IDS2000 Series (Not CE)
- OEM Dispensers (See page 11 for more info)

Drive	+	Pump Head	=	Complete Pump
Example: IDS2000A	+	Q3CKC	=	

IDS PDM (PUMP DRIVE MODULE)

MAX. Flow Pressure	Pump Drive Module	Piston Size Code	*Complete Pump
Dispense/Revolution			
.025	IDS2000ARH	RH00	
.05		RH0	
.10		RH1	
.08	IDS2000A	Q0	
.32		Q1	
.72		Q2	
1.28		Q3	

*TC & SMTRH pump heads are not included

Quick Run Module Foot Switch, Power Supply on/off - Dispense/ Continuous Control for IDS2000

Part Number# 400438



Precision Adjustment Stepper “STRH”

- Meter, Dispense, Aspirate, Flush
- Precision RH adjustable pump with step motor
- Valveless, Reversible, Self priming
- Ceramic low dead-volume wetted parts
- Ideal for Prototyping

Ideal for Prototyping



STRH PUMPS

MAX. Dispense Rates	Complete Pump Assembly	Wetted Parts	Price
Microliters / Revolution			
0 - 25 µl	STRH00CKCLF	Ceramic PVDF	
0 - 50 µl	STRH0CKCLF		
0 - 100 µl	STRH1CKCLF		

STRH

Dimensions:

5 1/4" x 3 1/4" x 3 3/4"
(134 x 83 x 96 mm)

Shipping weight:

2.2 lbs (1 kg)

Electrical:

23 frame step motor
1.8° step angle
4-lead bipolar parallel
3.5 A max. current

STQP & ST Duplex Pumps

Adjustable High Flow Stepper Pump “STQP”

- Precision variable displacement Q-Pump with integral stepper motor.
- Accommodates all Q Style pump heads and RH pump heads (with RH/Q adaptor)
- Ideal for OEM applications where accurate & frequent displacement changes are expected
- Available in ST2QP Duplex Ratio:Matic® configurations
- Ideal for prototyping
- Can be driven by FMI’s SCST-01, ICST-01, or a variety of commercially available stepper driver boards.



STQP

Duplex Ratio:Matic® Stepper Pumps “ST2”

- ST2 Duplex “Ratio:Matic®” for proportional flow
- One stepper motor and controller drive two pump heads
- Available in fixed and variable displacement models.
- Each pump head displacement is independently adjustable.
- Available as STH, STRH, STQ & STQP configurations, or combinations.
- Ideal for proportional metering & dispensing, as well as, dual line production dispensing.

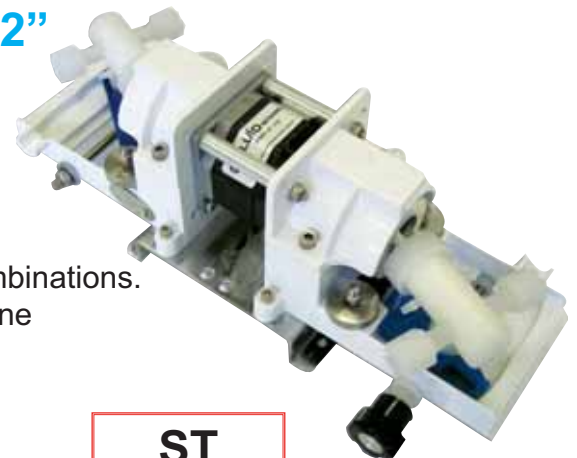

ST



“QP” Motorless Pedestal

High Flow - Rugged Duty



- No Valves to clog, hang up or service.
- One Moving Part - Piston.
- Drift-Free accuracy of better than $\pm 1\%$
- Ideal for OEM applications up to 1800 RPM
- Used extensively in laboratory, industrial, and OEM applications for both dispensing & metering up to 2300ml/min continuous flow.
- Typically driven by belt, chain or shaft coupling connected to your special motor drive, e.g. air, hydraulic, stepper, etc.
- Minimal torque requirement of 35 inch ounces.

QP

Model QP with CKC PHM

Dimensions:
6 3/8" x 4 3/8 x 5 1/8"
(162 x 111 x 130 mm)

Shaft extension:
5/16" dia. x 13/16"
(8 mm dia. x 3 mm)

Shipping weight:
5 lb. (2.25 kg)

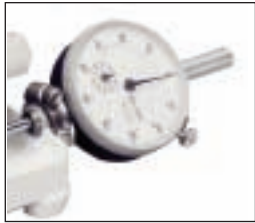

Q485 Dial Indicator for ultra fine flow adjustment (pg 20 for more info)



Rotational Sensors
See (pg 19 for more info)

LIVE ONLINE HELP

>> Chat live online with a fluid control expert.
www.fmipump.com

FLUID METERING, INC.
Valveless Metering Pumps & Dispensers

Have questions?
Chat live with an FMI application specialist at
www.fmipump.com

Example: Drive + Pump Head = Complete Pump
QP + Q1CKC =

QP PDM (PUMP DRIVE MODULE)

MAX. Flow/Pressure			PDM	Piston Code	Drive Price
ML/Rev.	PSIG	BAR			
.025	100	6.90	QP	RH00	
.05				RH0	
.08				Q0	
.10				RH1	
.32				Q1	
.72	Q2				
1.28	25	1.72		Q3	



Drive Options

Dial Indicator (pg. 20)

Part Number: - Q485

Price:

P56C Face Adapter (pg. 19)

Part Number: -P56C

Price:

Masterflex Adapter (pg. 17)

Part Number: -QP/M

Price:

PHM (PUMP HEAD MODULE)

Piston Size Code	Materials of Construction								
	CKC	CKY	CSC	CSY	SAN	SKY	SSY	STY	CTC
RH00									
RH0									
RH1									
Q0									
Q1									
Q2									
Q3									
Wetted Parts	Ceramic PVDF	Ceramic PVDF Carbon	Ceramic 316 SS	Ceramic 316 SS Carbon	Ceramic Teflon	316 SS PVDF Carbon	316 SS Carbon	316 SS Tefzel Carbon	Ceramic Tefzel
MAX.Temp	212° F	212° F	350° F	350° F	350° F	140° F	140° F	140° F	212° F
Options	(add Option Code & cost to Pump Module for complete price and part number)								
LF (pg.19)	N/C	N/C				N/C		N/C	N/C
W (pg.18)									
WT (pg.18)									
TC (pg.18)									
R479 (Pg.20)									
S ("Q" Only)									

*See page 28 "Pump Head Materials Configuration" for additional information.



Miniature Motorless "RH"

For Low Flow - High Precision



- Ceramic and PVDF standard wetted materials - also available in Tefzel
- 0 to 100 microliters per stroke
- Precision stroke to stroke = 0.5% or better
- Pressures from -10 to 100 psig
- Needs only 17 inch ounces of torque
- Requires only 2 1/4" panel space
- Standard 1/4" O.D. tubing or 1/4-28 female
- Adjustable while running or at rest
- 0 to 100% stroke length adjustment for maximum flow rate flexibility
- Easy grip flow control ring graduated in 450 divisions
- Linear speed vs. flow rate from 0 to 3600 RPM (360 ml/min)
- Standard and low flow configurations.

FMI Lab Pump Jr



Actual Size

RH Pumps

MAX. Flow/Pressure			Complete Pump Assembly	Wetted Parts	Price
µl / Stroke	PSIG	BAR			
0 - 25 µl	100	6.90	RH00SKY	316 SS/PVDF/Carbon	
0 - 25 µl			RH00STY	316 SS Tefzel Carbon	
0 - 25 µl			RH00CTC	Ceramic Tefzel	
0 - 50 µl			RH0CKC	Ceramic / PVDF	
0 - 100 µl			RH1CKC	Ceramic / PVDF	

RH-LF

RH-LF feature integrally molded 1/4-28 female low dead volume ports. This allows for quick connections to 1/16" & 1/8" O.D. micro bore tubing and fittings (FMI Q661 pg. 21).

Dimensions:

2 1/4" O.D. x 3 1/2"
(57 O.D. x 89 mm)

Shaft Extension:

5/16" dia. x 3/4" long
(8 mm dia. x 19 mm long)

Shipping weight:

2 lb (0.9 kg)



Drive Options

Low Dead Volume Pump Head (pg. 19)

Part Number: - LF

Price: N/C

Adapter for Q (PDM) (pg. 20)

Part Number: - RH/Q

Price:

Masterflex Adapter (pg. 17)

Part Number: - RH/M

Price:

See page 28 for pump head codes, material of construction

"RH/Q" Adapter See page 20



OEM version



RH

Actual Size





Lab-OEM-Production

Ideal for Prototyping



STRH

Precision Adjustment Stepper “STRH”

- Meter, Dispense, Aspirate, Flush
- Precision RH adjustable pump with step motor
- Valveless, Reversible, Self priming
- Ceramic low dead-volume wetted parts
- ST2RH Duplex “Ratio:Matic®” for proportional flow
- Ideal for Prototyping

MAX. Dispense Rates	Complete Pump Assembly	Wetted Parts	Price
Microliters / Revolution			
0 - 25 µl	STRH00CKCLF	Ceramic PVDF	
0 - 50 µl	STRH0CKCLF		
0 - 100 µl	STRH1CKCLF		



SMTRH

Sub-Microliter “SMTRH”

- 500 nL to 25 µl per dispense
- Meter, Dispense, Aspirate
- Valveless, Reversible, Self Priming
- Ceramic low dead-volume wetted parts



SCST-01

FMI Stepper Control Kit “SCST-01”

- Quick start control for all FMI stepper pumps
- Stroke rate to 1200 RPM maximum
- 7 dispense modes
- 0 - 5 VDC input control
- Automatic current reduction
- Stall detection & restart
- Easy hook-up
- Small size (board only 3 1/2” x 3 1/4” x 1 1/4” high)



KIT SCST-01 includes:
Power supply, cables and controller.

Intelligent Stepper Development Kit “ICST”

- Ideal for R&D and Prototyping.
- Complete Development Kit provides the ultimate in programming flexibility.
- Four "Pic-n-Run" ready-to-go programs or create your own.
- Control forward, reverse, speed, purge, suck-back, ramp up/down, profile, inputs, outputs . . . and more.

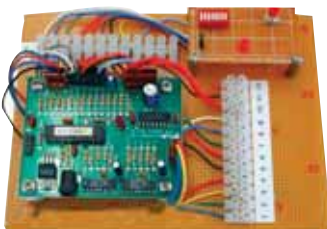

ICST



OEM Dispensers/Pumps

High Precision Step Motor Pumps for OEM Applications



- No Valves to clog, hang up or service.
- One Moving Part - Piston.
- Drift-Free accuracy better than $\pm 1\%$.
- Precision - CV of 0.5% or better.
- Ceramic and fluorocarbon fluid path.
- Displacement of 0 to 1280 microliters (1.28 ml) per revolution.
- 1.8° stepper motors with opto sensors.
- Excellent chemical resistance.
- 6 standard models and custom models.
- Special OEM pricing available upon request.



STH

Dimensions:
4 5/8" x 3 1/8" x 2 1/8" wide
(117 x 79 x 53 mm)

Shipping weight :
2 lb. (0.9 kg)

Low Flow "STH"

STH Pumps

MAX. Dispense Rates	Complete Pump Assembly *	Wetted Parts	Price
Microliters / Revolution			
0 - 25 μ l	STH00CKCLF	Ceramic PVDF	
0 - 50 μ l	STH0CKCLF		
0 - 100 μ l	STH1CKCLF		

23 Frame Stepper 6 wire motor std.

*Shown with optional 17 size motor

High Flow "STQ"

STQ Pumps

MAX. Dispense Rates	Complete Pump Assembly *	Wetted Parts	Price
Milliliters/Revolution			
0 - .32 ml	STQ1CKC	Ceramic PVDF	
0 - .72 ml	STQ2CKC		
0 - 1.28 ml	STQ3CKC		

*Standard 23 frame stepper motor shown



STQ

Dimensions:
6 1/2" x 3 5/8" x 3 1/4" wide
(166 x 91 x 82 mm)

Shipping weight :
3 lb. (1.35 kg)

Economical Fluid Control "RO"

- Economical, fixed displacement
- Reciprocating, Oscillating Ceramic Piston
- Valveless, Reversible, Self Priming
- Transfer, Wash, Aspirate, Flush

Price : Consult Factory



RO

Want Something Special-- Ask us!





“QD” High Speed - High Flows

For General Lab and Industrial Use



QD

Dimensions:
9 3/4" x 4 3/4" x 5 3/8"
(248 x 121 x 137mm)

Shipping weight:
10 lb (4.5 kg)

Electrical:
115 VAC, 60Hz, 1Ø, 1.25 amps, 1/25 Hp, 1725 RPM, shaded 4 pole, TEFC, sparkless, thermally protected with 3 prong power cord.
"Motor is UL reconized"



Q485 Dial Indicator for ultra fine flow adjustment see (pg 20) for more info

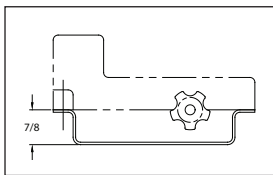

“Q” FIXED MOUNTING BASE KIT MB

Sturdy mounting base accessory for “Q” Line metering pumps. Allows pumps to be firmly bolted to surface in horizontal or vertical operating position. Hardware for attaching base to pump and instructions included.

- No Valves to clog, hang up or service.
- Ceramic and fluorocarbon standard wetted materials.
- One Moving Part - Piston.
- Drift-Free accuracy better than $\pm 1\%$.
- Flow rate infinitely adjustable from 0 to 2200 ml/min in either direction.
- Convenient multi-position tilt stand for wall or counter mounting.
- Rugged, long life, fan cooled, thermally protected, ball bearing motor.

Example: Drive + Pump Head = Complete Pump
QD + Q3CKC =

QD PDM (PUMP DRIVE MODULE)

MAX. Flow/Pressure				PDM	Piston Code	Drive Price
ML/MIN	GAL/HR	PSIG	BAR			
43.13	0.681				RH00	
86.25	1.3				RH0	
138.0	2.1				Q0	
172.50	2.7	100	6.9	QD	RH1	
552	8.6				Q1	
1242*	18.9	50	3.45		Q2	
2208*	30.0	25	1.72		Q3	

*See General Specifications note (pg 27)

Drive Options

230 VAC (50 Hz)*

Part Number: **-2**

Price:

Mounting Base (pg.12)

Part Number: **-MB**

Price:

Dial Indicator (pg.20)

Part Number: **-Q485**

Price:

Hazardous Duty

Part Number: **QDX**

Price:

PHM (PUMP HEAD MODULE)

Piston Size Code	Materials of Construction								
	CKC	CKY	CSC	CSY	SAN	SKY	SSY	STY	CTC
RH00									
RH0									
RH1									
Q0									
Q1									
Q2									
Q3									
Wetted Parts	Ceramic PVDF	Ceramic PVDF Carbon	Ceramic 316 SS	Ceramic 316 SS Carbon	Ceramic Teflon	316 SS PVDF Carbon	316 SS Carbon	316 SS Tefzel Carbon	Ceramic Tefzel
MAX.Temp	212° F	212° F	350° F	350° F	350° F	140° F	140° F	140° F	212° F
Options	(add Option Code & cost to Pump Module for complete price and part number)								
LF (pg.19)	N/C	N/C				N/C		N/C	N/C
W (pg.18)									
WT (pg.18)									
TC (pg.18)									
R479 (Pg.20)									
S (“Q” Only)									

*See page 28 "Pump Head Materials Configuration" for additional information.



Direct Current “RHB” Instrumentation Pumps



- 12, 24, 90 VDC motors with close-coupled RH Pump Heads.
- Widely used to inject discrete quantities of additive fluids into main discharge lines of tank trucks and pest control vehicles, as well as for environmental sampling & injection.
- Offers the advantage of mechanical adjustment of stroke length, plus electrical control of stroke rate by voltage variation.
- Extended motor shaft accepts user supplied Rotational Sensor.



RHB Pumps

MAX. Flow/Pressure			Complete Pump Assembly	Wetted Parts	MAX. Temp	Price
ML/MIN	PSIG	BAR				
65	100	6.90	RHB00SKY	316 SS/PVDF/Carbon	140° F	
130			RHB0CKC	Ceramic / PVDF	212° F	
260			RHB1CKC			

RHB

Dimensions:
8" x 3" x 3" wide
(203 x 76 x 76 mm)

Shipping weight:
7 lb (3.15 kg)

Electrical:
12 VDC, 4 amps, 2600 RPM,
totally enclosed, with 6" pigtail
leads. Shaft extension: 5/16"
dia. x 1" long with flat.

Drive Options

24 VDC (3 amps) for RHB

Part Number: -4

Price:

90 VDC (0.41 amps) for RHB

Part Number: -5

Price:

Direct Current “QB” For Mobile, and Remote Applications

- No Valves to clog, hang up or service.
- One Moving Part - Piston.
- Drift Free accuracy better than $\pm 1\%$.
- Offers the advantage of mechanical adjustment of stroke length, plus electrical control of stroke rate by voltage variation.
- Extended motor shaft accepts user supplied Rotational Sensor.



QB

QB PUMPS: Rated at 1800 RPM (or approximately 8 volts for 12 VDC models.)

Dimensions:
10 1/2" x 5" x 4 1/2" wide
(267 x 127 x 114 mm)
Shipping weight: 8 lb (3.6kg)

Electrical:
12 VDC, 4 amps; 24 VDC, 3 amps
90 VDC, 0.41 amps, totally
enclosed with 6" pigtail leads.
Shaft extension: 5/16" dia. x 1"
long with flat.

Example: Drive + Pump Head = Complete Pump
QB + Q1CKC =

QB PDM (PUMP DRIVE MODULE)

MAX. Flow/Pressure			PDM	Piston Code	Drive Price
ML/MIN	PSIG	BAR			
45	100	6.90		RH00	
90				RH0	
144			QB	Q0	
180				RH1	
576*	70	4.38		Q1	
1296*	30	2.07		Q2	
2304*	25	1.72		Q3	



Drive Options

Dial Indicator (pg.20)

Part Number: -Q485

Price:

Mounting Base (pg.12)

Part Number: -MB

Price:

90 VDC (0.41 amps)

Part Number: -5

Price:

*See Page 27 for General Specification notes



www.fmipump.com • pumps@fmipump.com • 800-223-3388 • 516-922-6050



“QG” Low Speed - Low Flows

For General Lab and Industrial Use

- No Valves to clog, hang up or service.
- One Moving Part - Piston.
- Drift-Free accuracy better than $\pm 1\%$.
- Can be combined with all RH and Q Pump Head Modules.
- Flow rate infinitely adjustable from 0 to maximum in either direction.



QG6,20



Dimensions:
10 3/4" x 4 7/8" x 5 3/4" wide
(273 x 124 x 146 mm)

Shipping weight:
10 lb (4.5kg)

Electrical:
115 VAC, 60 Hz, 1Ø, 1 amp,
6, 20 RPM,
shaded 2 pole, enclosed
ventilated, thermally
protected, with 3 prong
power cord - UL, CE.



Q485 Dial Indicator for
ultra fine flow adjustment
(see pg 20) for more info



Rotational Sensors
(see pg 19 for more info)

LIVE ONLINE HELP

» Chat live online with a
fluid control expert.
www.fmipump.com

FLUID METERING, INC.
Valveless Metering Pumps & Dispensers

Have questions?
Chat live with an FMI
application specialist at
www.fmipump.com

Drive + Pump Head = Complete Pump
Example: QG6 + Q1CSC =

QG PDM (PUMP DRIVE MODULE)

MAX. Flow/Pressure				PDM	Piston Code	Drive Price
ML/MIN	GAL/HR	PSIG	BAR			
0.15	.002	100	6.90	QG6	RH00	
0.30	.004	100	6.90		RH0	
0.48	.007	20	1.38		Q0	
0.60	.009	100	6.90		RH1	
1.92	.030	75	5.17		Q1	
4.32	.068	50	3.45		Q2	
7.68	.119	25	1.72	Q3		
0.50	.007	100	6.90	QG20	RH00	
1.00	.015	100	6.90		RH0	
1.60	.025	20	1.38		Q0	
2.00	.031	100	6.90		RH1	
6.40	.101	50	3.45		Q1	
14.40	.227	40	2.76		Q2	
25.60	.399	25	1.72		Q3	



Drive Options

230 VAC (50/60 Hz)*

Part Number: -2

Price:

24 VAC (50/60 Hz)*

Part Number: -3

Consult Factory

Mounting Base (pg.12)

Part Number: -MB

Price:

Dial Indicator (pg.20)

Part Number: -Q485

Price:

*Flow Rates are reduced approximately 18% when operating on a 50 Hz electrical supply.

PHM (PUMP HEAD MODULE)

Piston Size	Materials of Construction									
	Code	CKC	CKY	CSC	CSY	SAN	SKY	SSY	STY	CTC
RH00										
RH0										
RH1										
Q0										
Q1										
Q2										
Q3										
Wetted Parts	Ceramic PVDF	Ceramic PVDF Carbon	Ceramic 316 SS	Ceramic 316 SS Carbon	Ceramic Teflon	316 SS PVDF Carbon	316 SS Carbon	316 SS Tefzel Carbon	Ceramic Tefzel	
MAX.Temp	212° F	212° F	350° F	350° F	350° F	140° F	140° F	140° F	212° F	
Options	(add Option Code & cost to Pump Module for complete price and part number)									
LF (pg.19)	N/C	N/C				N/C		N/C	N/C	
W (pg.18)										
WT (pg.18)										
TC (pg.18)										
R479 (Pg.20)										
S ("Q" Only)										

*See page 28 "Pump Head Materials Configuration" for additional information.



Low Speed - Low Flows "QG"

For General Lab and Industrial Use



- A choice of five different drive speeds.
- Ceramic and fluorocarbon standard wetted materials.
- Long-life, fan cooled, thermally protected, ball bearing gear motors.
- Convenient multi-position tilt stand for wall or counter mounting.

QG PDM (PUMP DRIVE MODULE)

MAX. Flow/Pressure				PDM	Piston Code	Drive Price
ML/MIN	GAL/HR	PSIG	BAR			
1.25	.019			QG50	RH00	
2.50	.039				RH0	
4.00	.063				Q0	
5.00	.079	100	6.90		RH1	
16.00	.252				Q1	
36.00	.568			Q2	QG150	
64.00	.998	25	1.72	Q3		
3.75	.059			RH00		
7.50	.118			RH0		
12.00	.189			Q0		
15.00	.237	100	6.90	RH1	QG400	
48.00	.758			Q1		
108.00	1.706			Q2		
192.00	2.995	25	1.72	Q3		
10.00	.158			RH00		
20.00	.316			RH0	QG400	
32.00	.505			Q0		
40.00	.632	100	6.90	RH1		
128.00	2.022			Q1		
288.00*	4.550			Q2		
512.00*	7.987	25	1.72	Q3		



Drive Options
230 VAC (50/60 Hz)* Part Number: -2 Price:
24 VAC (50/60 Hz)* Part Number: -3 Price:
Mounting Base (pg.12) Part Number: -MB Price:
Dial Indicator (pg.20) Part Number: -Q485 Price:



QG50,150,400

Dimensions:
10 3/4" x 4 7/8" x 5 3/4" wide
(273 x 124 x 146 mm)

Shipping weight:
10 lb (4.5 kg)

Electrical:
115 VAC, 60 Hz, 1Ø, 1 amp,
50, 150, 400 RPM, shaded 2
pole, enclosed ventilated,
thermally protected, with 3
prong power cord - UL, CE.

*See Page 27 for General Specification notes

PHM (PUMP HEAD MODULE)

Piston Size	Materials of Construction									
	Code	CKC	CKY	CSC	CSY	SAN	SKY	SSY	STY	CTC
RH00										
RH0										
RH1										
Q0										
Q1										
Q2										
Q3										
Wetted Parts	Ceramic PVDF	Ceramic PVDF Carbon	Ceramic 316 SS	Ceramic 316 SS Carbon	Ceramic Teflon	316 SS PVDF Carbon	316 SS Carbon	316 SS Tefzel Carbon	Ceramic Tefzel	
MAX.Temp	212° F	212° F	350° F	350° F	350° F	140° F	140° F	140° F	212° F	
Options	(add Option Code & cost to Pump Module for complete price and part number)									
LF (pg.19)	N/C	N/C				N/C		N/C	N/C	
W (pg.18)										
WT (pg.18)										
TC (pg.18)										
R479 (Pg.20)										
S ("Q" Only)										

*See page 28 "Pump Head Materials Configuration" for additional information.



PD-60-LF
Pulse Dampener Accessory
(see pg 20) for more info.

LIVE ONLINE HELP

» Chat live online with a fluid control expert.

www.fmipump.com

Valveless Metering Pumps & Dispensers

Have questions?
Chat live with an FMI
application specialist at
www.fmipump.com





“QBG” Low Current DC

Ideal for extended 12/24 volt battery operation in remote locations. They are rated 60 RPM at 12 VDC and 120 RPM at 24 VDC.



QBG

Dimensions:
9 3/4" x 5 1/4" x 6 3/4" wide
(246 x 135 x 171 mm)

Shipping weight:
7 lb (3.15kg)

Electrical:
12/24 VDC, 60-120 mA
(depending on load), with 6" pigtail leads.



RHSY



Dimensions:
5" x 5" x 4" wide
(127 x 127 x 102 mm)

Shipping weight:
4 lb (1.8kg)

Electrical:
115 VAC, 60 Hz, 1Ø, .08 amps,
with 3 prong power cord - , CE.

	Drive	+	Pump Head	=	Complete Pump
Example:	QBG	+	Q1CKC	=	

QBG PDM (PUMP DRIVE MODULE)

MAX. Flow/Pressure			PDM	Piston Code	Drive Price
ML/MIN	PSIG	BAR			
1.5				RH00	
3.0	60	4.1		RH0	
4.8				Q0	
6.0			QBG	RH1	
19.2	30	2.07		Q1	
43.2	20	1.38		Q2	
76.8	10	0.70		Q3	



Drive Options
Dial Indicator (pg. 20) Part Number: -Q485
Price:
Mounting Base (pg. 12) Part Number: -MB
Price:

Note: Flow rates shown for QBG are based on 12 VDC, 60 RPM operation.

“RHSY” Synchronous Pumps

The Ultimate in Low Flow Metering Accuracy

- Drift-Free accuracy better than $\pm 1\%$ independent of load variations or fluctuations in line voltage.
- Compact design “RH” pump with synchronous motor assembly.
- Micrometer-like fine adjustment using an easy grip flow control ring graduated in 450 divisions.
- Choice of 150, 300, and 600 RPM through a simple and safe belt arrangement change.
- Forward-Off-Reverse switch for instant flow direction control.
- Available with low dead volume pump head and low flow tubing kit.

RHSY Pumps

MAX. Flow/Pressure			Complete Pump Assembly	Wetted Parts	MAX. Temp	Price
@150 RPM ml/min	@300 RPM ml/min	@600 RPM ml/min				
3.75	7.5	15	RHSY00SKY	316 SS / PVDF / Carbon	140° F	
7.5	15	30	RHSY0CKC	Ceramic / PVDF	212° F	
15	30	60	RHSY1CKC			

Drive Options
230 VAC (50Hz,..04 amp) * Part Number: -2
Price:

*Flow Rates are reduced approximately 18% when Pump Drive Module is operating on a 50 Hz electrical supply.



Pneumatic "PD"

For Non-Electric Operation



- Provides a compact, variable speed, air powered drive.
- Ideal power alternative when electrical power source not available.
- SPD** up to 1800 RPM.
- GPD** up to 400 RPM.



Example: Drive + Pump Head = Complete Pump
 SPD + Q1CKC =

SPD PDM (PUMP DRIVE MODULE)

MAX. Flow/Pressure			PDM	Piston Code	Drive Price
ML/MIN	PSIG	BAR			
45				RH00	
90				RH0	
144	100	6.90	SPD	Q0	
180				RH1	
576	70			Q1	
1296	50	3.45		Q2	
2304	25	1.72		Q3	



Drive Options
Dial Indicator (pg. 20) Part Number: -Q485
Price:
FMI Pulse Dampener (pg. 21) Part Number: "58003"
Price:

**SPD
GPD**

Dimensions:
8" x 3" x 3" wide
(203 x 76 x 76 mm)

Specification:
SPD: Air requirements
9-10 CFM at 40 psig.
Air Inlet size: 1/8" (F) NPT.

GPD: Heavy-duty gear box
Air requirements:
14-16 CFM at 40 psig.
Air Inlet size: 1/8" (F) NPT

Shipping weight: 9 lb (4.05 kg).

*See Page 27 for General Specification

FMI Masterflex® Kits QP/M & RH/M

Enhance your Existing Masterflex Pump Drives

- Move to state-of-the-art valveless piston technology.
- Extend your pump's operating pressure up to 100 psig.
- Improve your long term accuracy to better than $\pm 1\%$.
- Add precise mechanical flow adjustment to your L/S™ drives.
- Increase your pump's efficiency by providing dual proportional fluid metering when adding FMI's CeramPump® technology to an existing L/S™ peristaltic pump head.
- Ceramic and fluorocarbon standard wetted materials.
- Installs in minutes to your L/S™ standard pump head, L/S™ EASYLOAD pump head, or directly to any L/S™ drive
- Flow rates from microliters to 768 ml/min.



QP/M

Masterflex- Reg TM of Cole-Parmer Instrument Co.
 L/S - Reg TM of Cole-Parmer Instrument Co.
 EASY-LOAD - Reg TM of Cole-Parmer Instrument Co.

KIT # QP/M



RH/M

KIT # RH/M (See page 9)





Options

“W”, “WT” Isolation Gland Pump Head Modules

- For saline, slurries, abrasives, particulates, anaerobics, and crystal forming fluids.
- Isolates main pumped fluid from seal area and atmosphere.
- 2 extra ports for Gland “Barrier” liquid or gas.
- For Q1/Q2CKC, Q3CKC, CKC-LF, & CSC Pump Head Modules.

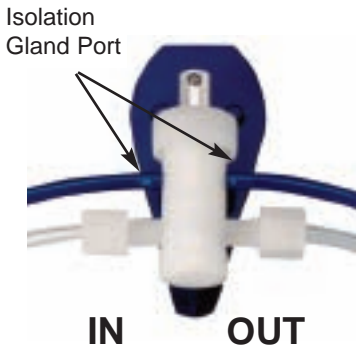

CKCW

“CKC-W” Standard

- Temperature to 212°F.
- Pressure to 60 psig.
- Ceramic piston and liner in fluorocarbon cylinder case.
- Main flow ports for tubing up to 1/2” I.D. using special adapters; Gland ports: 1/8” barbs for 1/8” I.D. tubing

CKC-W

3CKC-W



CSC-W

“CSC-W” Stainless Steel

- Gland Design temperature to 350° F
- Pressure to 100 psig
- Ceramic piston and liner in 316 SS case.
- Main flow 1/4” NPT female; Gland Ports: 10-32 female

CSC-W



CSC-WT

“CSC-WT” High Temperature

- For maintaining process fluid temperatures and pumping viscous fluids
- High temperature to 350°F
- Accepts 2 standard 1/4” x 1” cartridge heaters & thermocouple
- Pressure to 100 psig
- Ceramic piston and liner in 316 SS cylinder case
- Main flow 1/4” NPT female ports; Gland Ports 1/8” NPT female

CSC-WT



CSC-TC

“CSC-TC” Tri-Clamp Pump Head Modules

- For 3/4” Tri-Clamp® style sanitary flange fittings.
- Quick assembly-disassembly without tools.
- Ideal for CIP or disassemble for sterilization.
- For beverage, food, pharmaceutical and biotech applications.
- 316 SS and ceramic wetted path for “Q” pumps only.

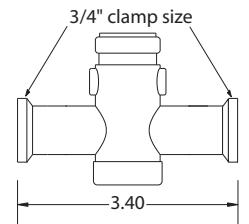

CSC-TC



Options



Pump Heads "LF"

- For low flow (under 50 ml/min), and Zero Dead Volume Applications.
- Direct connection to 1/4-28 low flow fittings
- RH-LF & Q-LF*** pump heads feature integrally molded 1/4-28 female low dead volume ports. This allows for quick connections to 1/16" or 1/8" O.D. micro bore tubing and fittings such as FMI Q661 (pg 21).
- Add suffix "LF" after Pump Head configuration

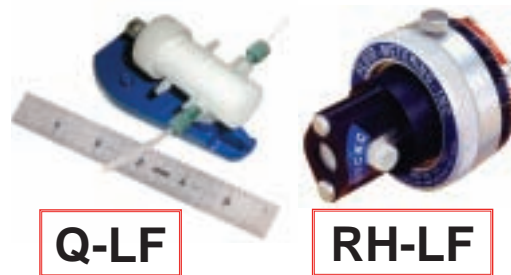

* polypropylene case

Proximity Type Rotational Sensor

PART NO.	FORM	CONTACT RATING	MAX RPM
PRS-1	SPST-N.O.	10 Watts, Max.	1000

Life: 50 Million Operations at 5 VDC, 10 mA

HES-6

Hall Effect Electrical Specification

PART NO.	Supply Voltage (VDC)	Supply Current (mA max.)	Output Type	Output Voltage (V)	Output Current (Max.)	6" Leadwires
HES-6	4.5 TO 24	10.0	Sink	0.4	40mA	22 gauge teflon insulated

Life: Indefinite

PRS-1

Hall Effect Sensor



Sanitary Pump Heads "SAN"

- Ideal for accurate and dependable handling of discrete fluid streams in sanitary applications.
- No internal threads or blind holes to harbor bacterial growth.
- Easily dismantles for scrubbing, brushing, & sterilization
- 316 SS and Teflon® fluid surfaces highly resistant to chemical & biological attack.
- Ideal for Food, Dairy, Brewery, Pharmaceutical, & Biotech applications.

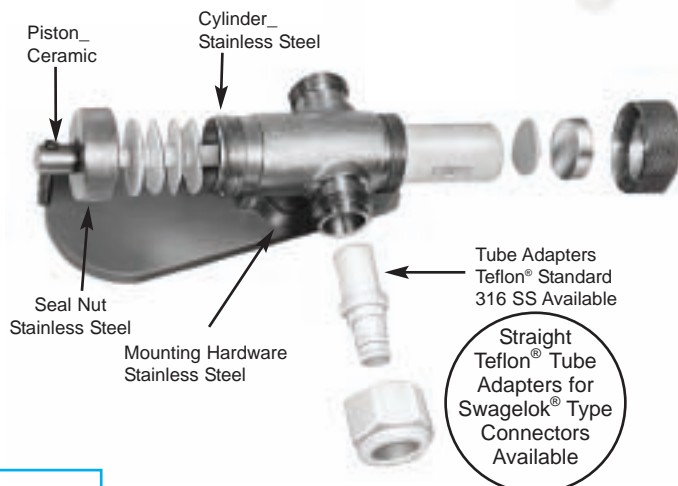

ALL STAINLESS STEEL VERSION AVAILABLE WITH SS PORT NUTS, TUBE ADAPTERS & CARRIER -"SAN-S"

SAN SAN-S

DESIGNED FOR QUICK DISASSEMBLY FOR MAXIMUM CLEANING

Adapter Kit "P56C"

- Adapter Kit for easy hook-up to your NEMA 56C FACE Foot Mount motor.
- Requires pump Drive Module QP
- Kit includes adapter, coupling and hardware

Shipping Weight: 4 lb (1.80 kg)

P56C

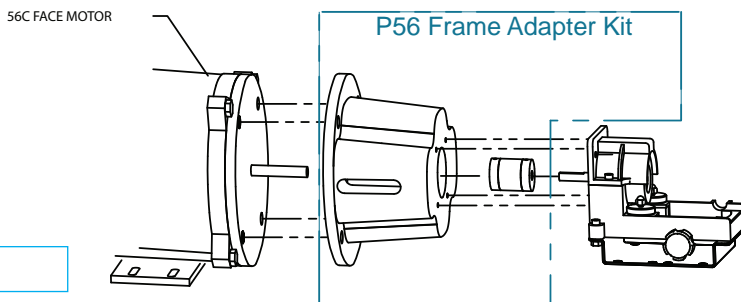



Accessories

“R479” Low Flow Isolation Kit

- Low flow adapter for stainless steel "Q" pump heads (except SAN).
- Isolates stainless steel cylinder case from process fluid for maximum chemical inertness.
- 1/4-28 female thread provides minimal system dead volume.
- Typically used with FMI "Q661" Small Bore Tubing Kit.
- Ideal for chromatography applications when used with "PD-60-LF" Pulse Dampener.
- For flows up to 50 ml/min and pressures to 100 psig.



R479

R479 Kit for LOW FLOW APPLICATIONS(Replaces R412, when used)

#R478 Consists of ten spare ferrules

Kit #R479 Consisting of four ferrules, two adapters & assembly/removal tools

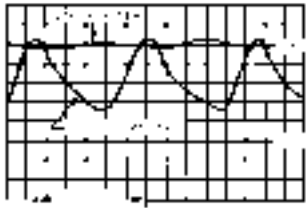

Actual Recorded Pulse Pattern of an FMI LAB PUMP with and without the PD-60-LF

“PD-60-LF” Pulse Dampener

- Provides pulseless flow for low flow metering applications
- Suppresses approximately 90% of pulse magnitude.
- Corrosion resistant 316 SS and Teflon® wetted surfaces.
- Excellent reduction of baseline drift & noise in feeding low pressure LC systems.
- For flows up to 50 ml/min & stroke rates up to 150 RPM against head pressures of 10 to 65 psig.
- Accepts standard 1/4-28 low flow tubing accessories.
- Includes isolated pressure gauge.



PD-60-LF

PD-60-LF

“RH/Q” Adapter



“RH/Q” Adapter

- Adds versatility to your RH pump head by adapting it to any "Q" pump drive.
- Simple installation of adapter to RH pump head using only 3 screws.
- Pump assembly can easily be slipped onto the Drive Module in seconds without tools.

Kit #RH/Q

RH/Q

“Q485” Dial Indicator Kit

- Ultra-precise flow adjustment for "Q" pumps.
- Responds to the slightest adjustment of the "Q" pump adjusting knob.
- Each increment on direct reading dial represents 1/1000 of maximum flow.
- Easily attaches to all "Q" Pump bases.
- Can be ordered with pump or separately.



Q485

Kit #Q485



Accessories



“Q661” Small Bore Tubing Kit

1/4-28 Fittings and 1/16”, 1/8” O.D. Teflon Tubing

Designed for all LF Pump Heads and to complement the FMI R479, R412-5K, and PD-60-LF, the Small Bore Tubing Kit has a flangeless design that eliminates the need for special tools and assures leak-free, zero dead-volume connections. They provide Tefzel® and Teflon® wetted surfaces.



Q661

Kit Q661 - 1/16” & 1/8”

Contains Both
Q661A and Q661B

Kit Q661A - 1/16”

10’ - 1/16”O.D. x 1/32” I.D. TFE Tubing
10 - Delrin Nuts (Black)
10 - Tefzel Ferrules (Blue)

Kit Q661B - 1/8”

10’ - 1/8”O.D. x 1/16” I.D. TFE Tubing
10 - Delrin Nuts (Green)
10 - Tefzel Ferrules (Yellow)

Kit Q661C - 1/8”

10’ - 1/8”O.D. x 1/16” I.D. TFE Tubing
10 - Teflon Nuts (White)
10 - Tefzel Ferrules (Yellow)



Low Flow Barb Adapters for 1/16” and 1/8” I.D. Tubing

Threaded 1/4-28 UNF Fitting to Kynar Barb Bottom sealing, rotating adapters consisting of a white nylon 1/4-28 fitting with 5/16” hex nut and Kynar (fluid path) insert barb.



#110873A for use with 1/8” (3.2 mm) I.D. tubing. Pkg. of 10



#110874A for use with 1/16” (1.6 mm) I.D. tubing. Pkg. of 10



“PD-HF” In-Line Pulse Suppressor

(For High Flow Applications)

New InLine Pulse Suppressor for high flow systems of 50 ml/min or greater and stroke rates higher than 150 against head pressures of 10 to 65 psig. Unique encapsulated polyethylene bellows design that eliminates tubing vibrations and cavitation problems. Easy to connect 1/4” compression fittings. Best results achieved when installed on both suction and discharge lines.



Model PD-HF

PD-HF

Corrugated Teflon® Tubing Pulse Suppressor

(For High Flow Applications)

Highly flexible no kink tubing for high flow, 50 ml/min or greater, high pressure (100 psig) applications. Eliminates cavitation and mechanical stress. Best results when used on both suction and discharge lines. Slips over 3/8” barbed fitting. 3/8”I.D.x12” long



#58003

Tubing Adapters

(For Plastic Case Pump Heads)

The integrally molded port fittings on the standard FMI Type K pump heads accept all 1/4” O.D. tubing. For other tubing arrangements, special port adapters are required.

#R412-0K	Adaptor for 1/8” I.D. Tubes
#R412-1K	Adaptor for 1/4” I.D. Tubes
#R412-2K	Adaptor for 3/8” I.D. Tubes
#R412-6K	Adaptor for 1/2” I.D. Tubes
#R412-5K	Adaptor for 1/4-28 ferrule fittings
#H476K	Adaptor for 1/8” O.D. Tubes
#110949	Adaptor for 6 mm O.D. Tubing





"H" Style Pump Typical Flow Data

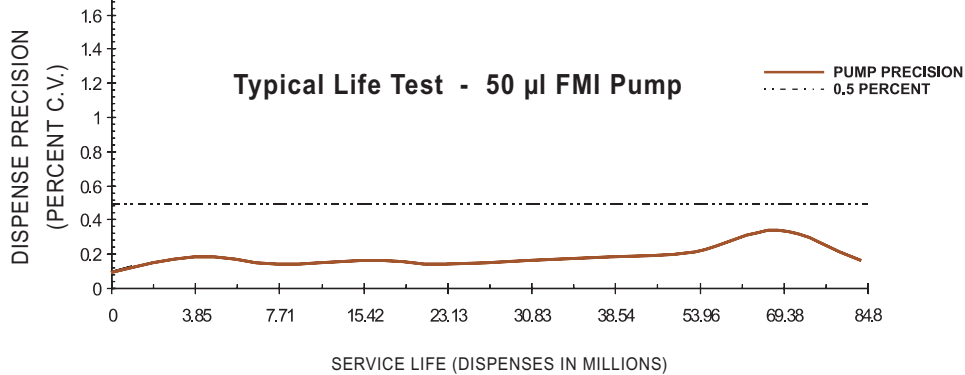
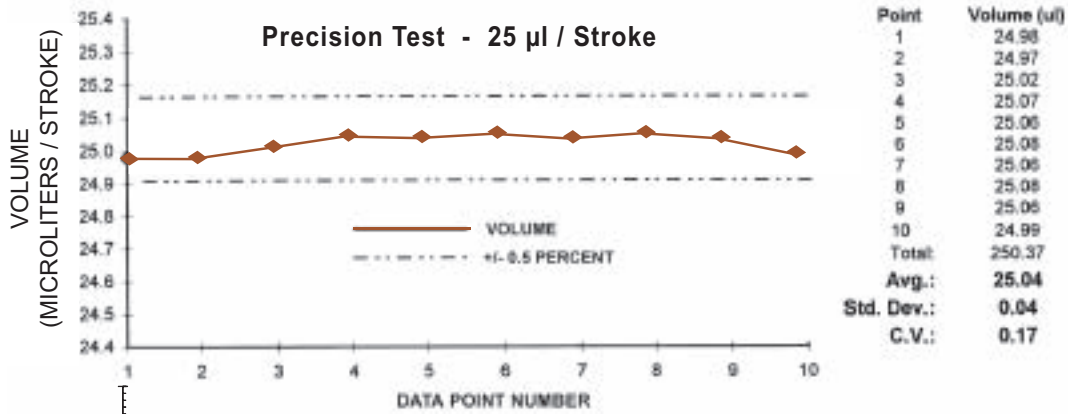
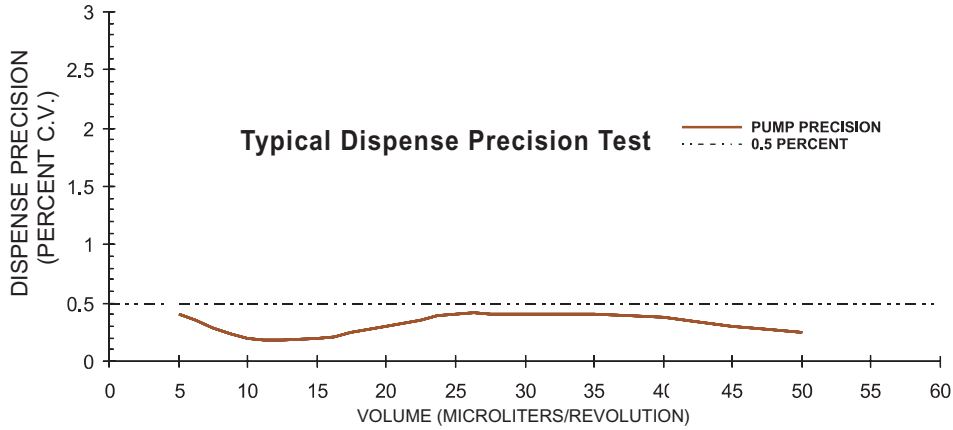

Precision
Repeatability and degree of variation of a set of values

Accuracy
How close the average value is to the true value

FMI Pumps
Accuracy: 1%
Precision: 0.5% (% C.V.)



“Q” Typical Performance Curves



Performance curves shown below are applicable to the new “Q” line of metering pumps.

Performance Curve shown represents a test run on an FMI LAB PUMP handling ambient air at 70°F with CKY Pump Head Module.

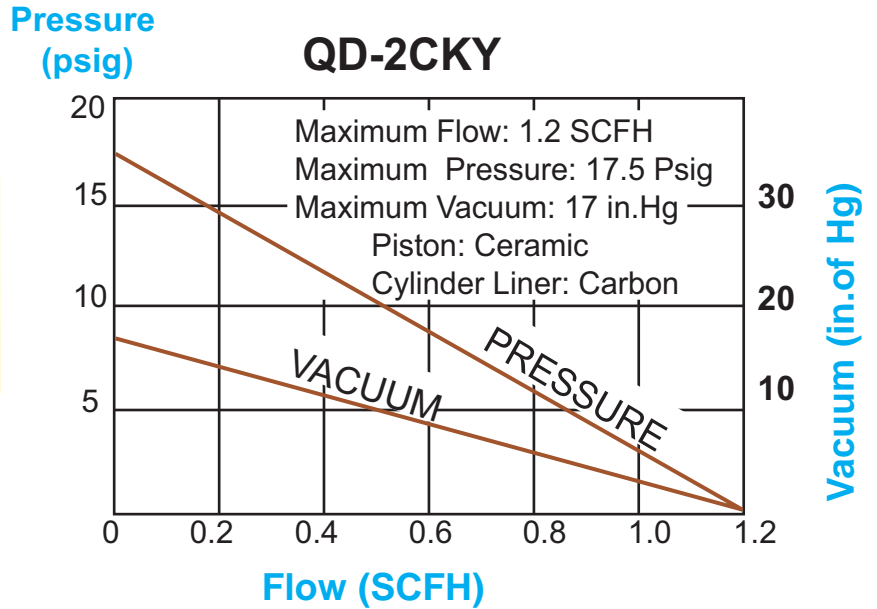

PERFORMANCE FLOW CURVES: Typical flow “curves” for FMI LAB PUMPS with “CSC” pump heads handling water at a pump setting of 100% full stroke. Internal fluid slip (decrease in flow with increased pressure) is least at 100% and increases as stroke displacement is decreased. Always select a pump with maximum output nearest your actual requirement.

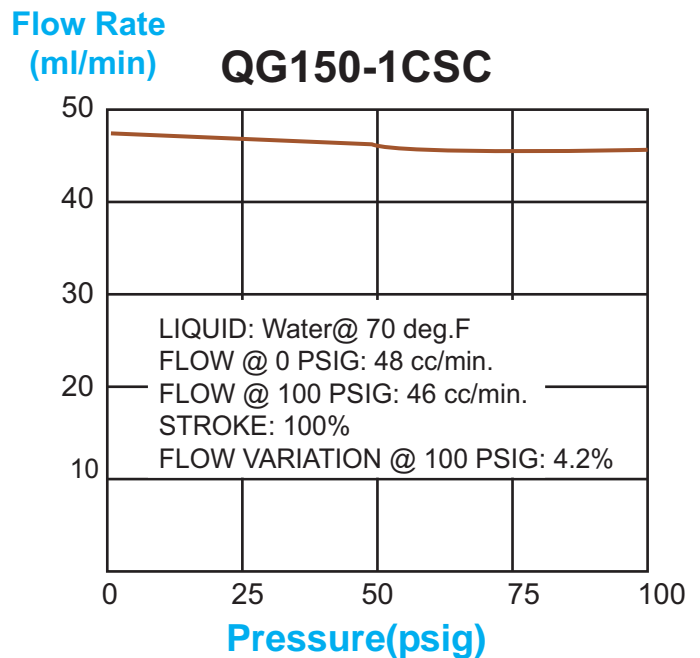
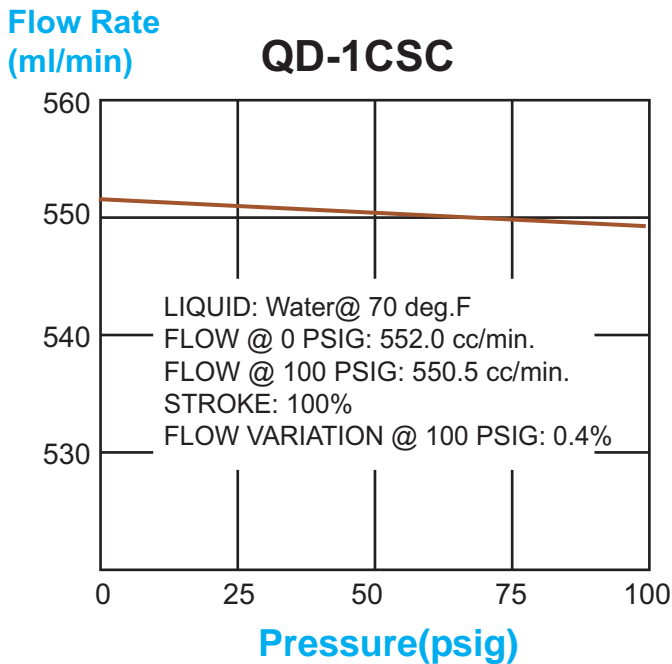

Nearly 50 years of pump and dispensing knowledge. Tell us your needs- we have the answers.





One Dispenser / Pump For all your Applications

Valveless Syringing Aspirate & Dispense

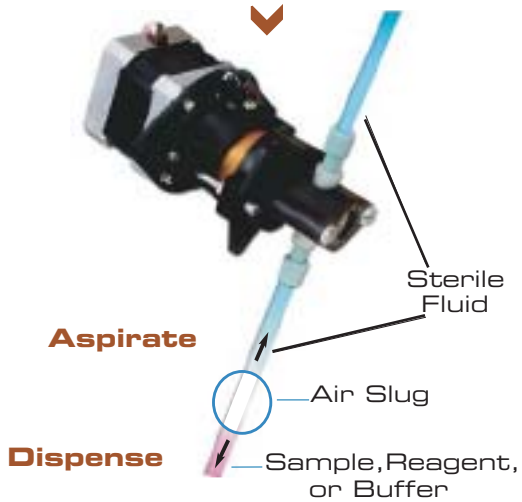

Fast Prime Flush & Wash

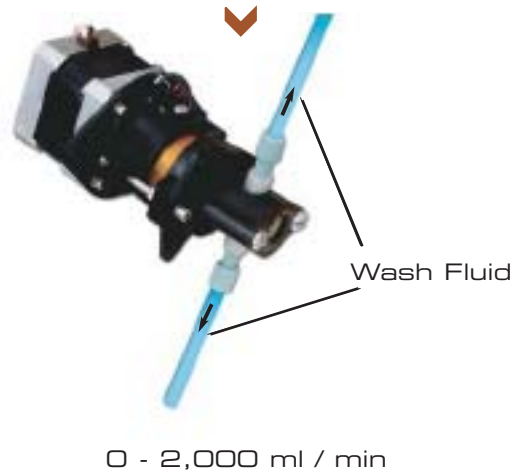

Continuous Dispensing



Continuous Metering

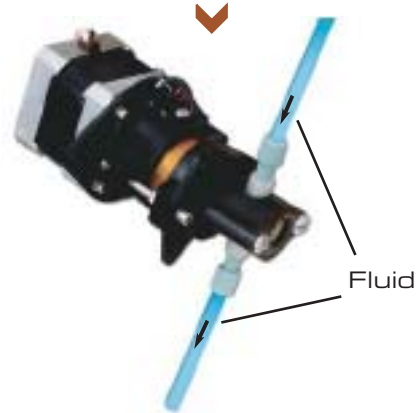

*FMI Dispensers
& Metering pumps
Can Do it ALL...*

*Call us
with your
Application*



Typical Applications



Typical Fluid Metering & Dispensing Applications

Medical

Blood Analyzer sample & reagent fluid control
Contact Lens Mfg. - Monomer Dispensing
Dialysis Systems
Immunoassays & MicroPlates
Solvent welding for Disposable Kits

Analytical Instrumentation

TOC Analyzers
Particle Analyzers
Viscosity Instrumentation
Titration Equipment
Liquid Chromatography
Water & Wastewater Monitoring
Stack Gas Monitoring

Industrial

Agricultural & Pesticide Spraying Systems
On-Site Petroleum Additive
Paints, Dyes, Inks, & Pigments
Lubricant Dispensing
Ferofluid dispensing for Speaker Mfg.

Food, Dairy, & Beverage

Aseptic Packaging - Peroxide Dispensing
Preservative Treatment of Meats & Poultry
Nutrient & Color Addition
Brewery additives
Vitamin Addition for Milk
Color Addition for Yogurt
Cottage Cheese Mfg.
Candy Polishing

Electronics

Plating Bath Chemicals
Semiconductor Chemical Distribution
Circuit Board Cleaning Systems
Battery Manufacturing
CMP & ECP Wafer Processing
Flux Addition for Wave Soldering
Wire Coating for Stators & Armatures

LIVE ONLINE HELP

>> Chat live online with a fluid control expert.

www.fmipump.com

FMI FLUID METERING, INC.
Valveless Metering Pumps & Dispensers

*Tech Questions?
FMI has nearly 50 years of fluidics expertise. We Can help with your simple or unique application. If you need help ask us. We have answers.*





Valveless Ceramic Dispensers & Metering Pumps Since 1959!

- No Valves, Drift-Free Operation.
- One moving part.
- Accuracy better than $\pm 1\%$.
- Precision Dispensing - CV of 0.5% or better..
- Flow rates from microliters to 4600 ml/min.
- Positive Displacement up to 200 psig.
- Viscosity Independent - Unaffected by viscosity of fluids.
- Millions of Maintenance-Free Cycles.
- Inert, corrosion resistant fluid path - ceramic & fluorocarbon standard.
- Self-priming to 15 feet, vertical lift.
- Instant Reversibility - While running.
- Large Selection of Drives - Fixed, variable, pneumatic, stepper, hazardous duty and OEM.
- Delivery from Stock - No waiting time.

OPERATION

The valveless pumping function is accomplished by the synchronous rotation and reciprocation of the ceramic piston in the precisely mated ceramic cylinder liner.

One complete piston revolution is required for each suction /discharge cycle as shown.

The piston always bottoms for maximum fluid and bubble clearing.

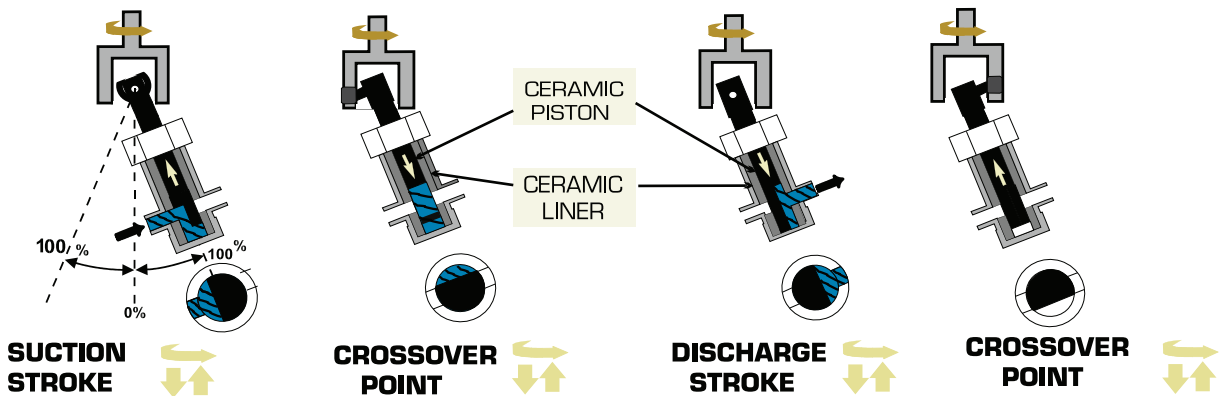

The piston rotates and reciprocates. As the piston is pulled back and the piston flat opens to the inlet port, suction is created and fluid fills the pump chamber. As the piston reaches the highest point in the reciprocation cycle, the pump chamber is now at its maximum volume capacity. Continuing the rotation, the inlet port is then sealed

and crossover occurs. As the inlet port is sealed and the pump chamber is full, the outlet port opens up. **Only one port is open at any time and at no time are both ports interconnected.**

Continuing the rotation and reciprocation, the piston is forced down and the piston flat opens to the outlet port. Discharge is created and fluid is pumped out. The piston bottoms for maximum fluid and bubble clearing. Continuing the rotation, the outlet port is then sealed

and crossover occurs. As the outlet port is sealed and the pump chamber is empty, the inlet port opens to start another suction stroke. **Only one port is open at any time and at no time are both ports interconnected.**

EASY FLOW RATE ADJUSTMENT

- Moving the pump head position changes the piston stroke length and, in turn, the flow rate.
- Infinite fine flow adjustments between zero and 100% flow rate.
- Flow rate indicator provides for accurate and simple linear calibration.
- Flow rate can be changed while pump is operating or at rest.

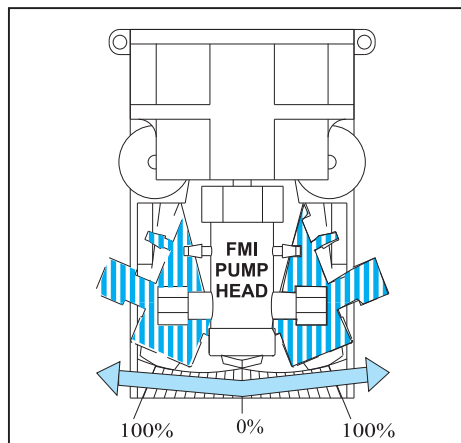

On all FMI pumps, flow rates may be altered when operating or at rest. On the "Q" line this is done by turning the Flow Control Knob which moves the flow rate indicator along a fixed 20 unit scale linearly calibrated "10-0-10". The "10" equals 100% flow rate in that direction, "0" equals zero flow. To improve the fine adjustment of the flow rates on the "Q" line, there is an optional **Dial Indicator Kit Q485** which provides for 1000 discrete settings. The "RH" line flow adjustment is accomplished by turning an easy-grip Flow Control Ring graduated in 450 divisions from 0 to 100% flow.



How To Order



1. Determine your flow rate in ml/min and your pressure requirements in PSIG.
2. Check that the drive power fits your application, i.e. AC, DC, stepper, etc.
3. Check the Piston Size Code for your flow rate and select a Pump Drive Module plus options.
4. Go to page 28 and select a Pump Head Module (PHM) compatible with your fluid and application.

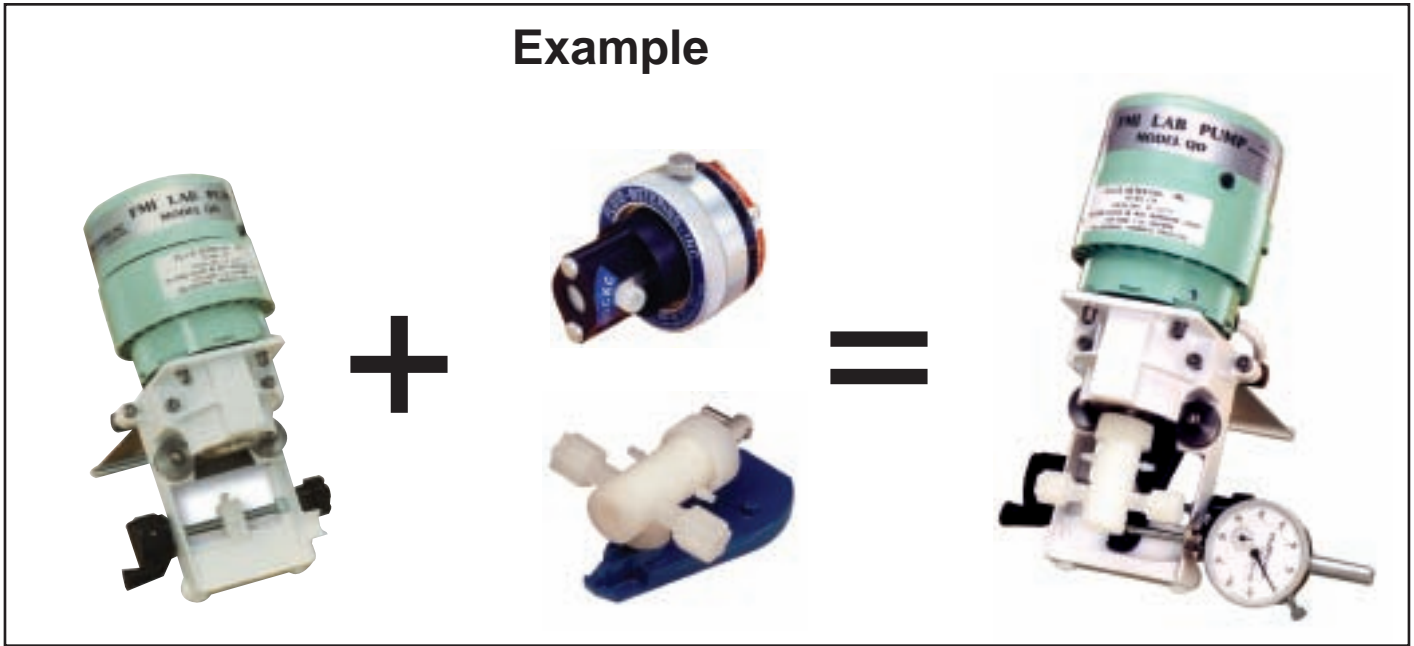

Example

Q PUMP DRIVE MODULE	Q OR RH PUMP HEAD MODULE	COMPLETE PUMP ASSEMBLY
Pump Drive: QD +Option(s): Q485 Cost: _____	Pump Head: Q-1CKC Option(s) W Cost: _____	= Total Cost: Pump Drive Modules, Pump Head Modules and options are mounted, tested and shipped as one unit when ordered together.
Pump Drive: _____ \$ _____	Pump Head: _____ \$ _____	
+ Option: _____ \$ _____	+ Option: _____ \$ _____	
Cost: _____ \$ _____	Cost: _____ \$ _____	= Total Cost: \$ _____

Not Sure What you need? Chat with us!

LIVE ONLINE HELP
 >> Chat live online with a fluid control expert.
www.fmipump.com
FLUID METERS, INC.
 Valveless Metering Pumps & Dispensers

Have questions?
 Chat live with an FMI application specialist at
www.fmipump.com

GENERAL SPECIFICATION NOTES FOR ALL PUMPS*

1. Physical characteristics of your pumped fluid may affect the rating/capacity relationships shown in the performance tables for each FMI unit.
2. The maximum flow rates shown in the tables are for **H₂O** at 2 psig.
3. Flow rates are infinitely variable from zero to maximum capacities shown.
4. Pumping capacities are reduced approximately 18% when the Pump Drive Module is operating on a 50 Hz electrical supply.
5. **Fluorocarbon cylinder cases (Q line only) are rated for a maximum pressure of 60 psig or the lower pressure shown in the charts.**
6. 3/8" I.D. tubing or greater is required for flows higher than 500 ml/min.
7. 1/2" I.D. tubing or greater is required for flows higher than 1200 ml/min.





Pump Head Codes & Materials

The table below provides codes for all available Pump Head Modules (PHM). After selecting the appropriate Pump Drive Module (PDM) and Piston Size Code, (refer to Drive Section, pages 2-16) select a PHM and available options below. FMI pump heads are made from various materials of construction for use in most applications. All FMI pumps are modular in design. The Pump Head

Modules can be easily removed for cleaning or replaced with a spare pump head for use with different fluids. Some customers have separate pump heads for use with each fluid handled or flow rate desired. When ordered together, Pump Drive Modules, Pump Head Modules, and options are mounted, tested and shipped as one unit.

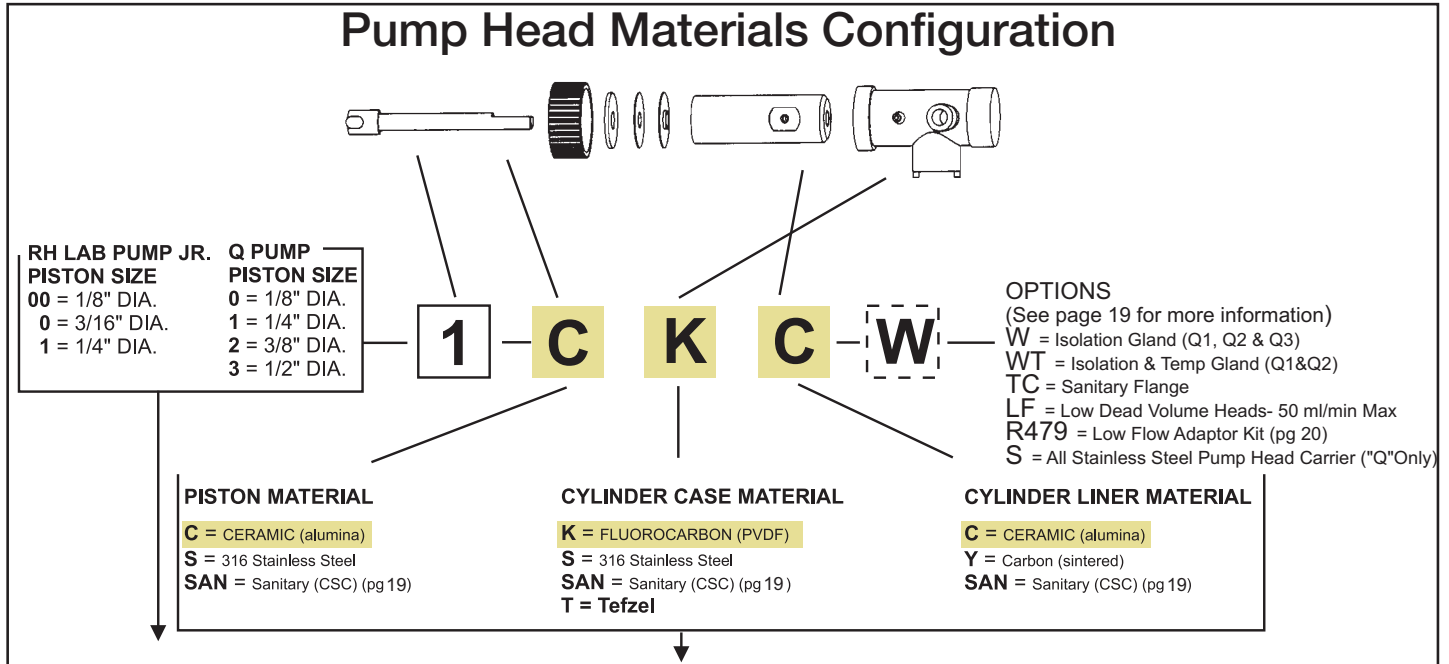

PHM (PUMP HEAD MODULE)

Let us Help you make a selection

LIVE ONLINE HELP

>> Chat live online with a fluid control expert.
www.fmipump.com

FLUID METERING, INC.
Valveless Metering Pumps & Dispensers

Have questions?
Chat live with an FMI application specialist at
www.fmipump.com

Piston Size Code	Materials of Construction								
	CKK	CKY	CSC	CSY	SAN	SKY	SSY	STY	CTC
RH00									
RH0									
RH1									
Q0									
Q1									
Q2									
Q3									
Wetted Parts	Ceramic PVDF	Ceramic PVDF Carbon	Ceramic 316 SS	Ceramic 316 SS Carbon	Ceramic Teflon	316 SS PVDF Carbon	316 SS Carbon	316 SS Tefzel Carbon	Ceramic Tefzel
MAX.Temp	212° F	212° F	350° F	350° F	350° F	140° F	140° F	140° F	212° F
Options	(add Option Code & cost to Pump Module for complete price and part number)								
LF (pg.25)	N/C	N/C				N/C		N/C	N/C
W (pg.24)									
WT (pg.24)									
TC (pg.24)									
R479 (Pg.26)									
S ("Q" Only)									

See Materials of Construction section for more information on wetted parts - pg 29



Materials of Construction



FMI fluid contact components are fabricated of carefully selected materials. Each one has discrete characteristics of physical strength, abrasion resistance, and dimensional stability under varying conditions of pressure, temperature, and resistance to attack by certain chemicals. Since no one material possesses all of the characteristics required to handle all chemicals under all possible conditions, FMI offers a selection of materials of construction for each pump component that fluids contact during the pumping process. These components and materials are identified on page 28 of the catalog by code designation, common usage names and trade names.

General Characteristics are as follows:

C - Ceramic

Ceramic is used in most of the pumps for piston and/or cylinder liners. Ceramic pistons may be used with ceramic and carbon cylinder liners. Ceramic cylinder liners can only be used with ceramic pistons.

Sapphire hard, fused crystalline Ceramic Al₂O₃, excellent chemical resistance, thermal stability and mechanically resistant to common abrasives.

Caution: Subject to binding or freezing when stored after improper cleaning - brittle and subject to fracture under sudden impact loading - not suitable for very "dry" fluids such as hexane.

K - Fluorocarbon

Fluorocarbon PVDF, is used for some **cylinder cases and tubing fittings**. Autoclavable @ 240°F maximum. Good chemical tolerance to most fluids.

Caution: Sensitive to degrading effects of some organic solvents, esters, and ketones.

S - Stainless Steel 316

Stainless Steel 316 is used for some **pistons, cylinder cases and/or tube fittings**. Not to be used as piston with ceramic cylinder liner.

Excellent chemical, and physical strength characteristics.

Caution: Subject to attack by some halides, strong acids, and bases - subject to surface abrasion and wear in piston application.

Y - Carbon

Carbon is used for some **cylinder liners**. Suitable for use with stainless steel and ceramic pistons.

Hard crystalline stage, ingot sintered, pure carbon chemically resistant to most commonly used fluids.

Caution: Sensitive to strong oxidants and all abrasive materials.

T - Tefzel, Dupont.

Fluoropolymer E-TFE - Used for **cylinder cases** in some FMI Pump Head Modules. Excellent chemical resistance to most acids, bases and solvents. Autoclavable @ 240°F maximum.

Rulon®AR, Saint-Gobain

Fluorocarbon, filled PTFE - Used for **lip seals** in some FMI pump heads. Excellent chemical resistance, - physically soft, resilient and wear resistant - abrasive to soft metals and should therefore not be used with "S" pistons in high stroke rate applications.

Rulon®J, Saint-Gobain

Fluorocarbon, filled PTFE - Used for **lip seals** in some FMI pump heads. Good chemical resistance, sensitive to some organic solvents, strong acids and bases - physically soft, resilient and non-abrasive.

Teflon®, Dupont Co.

Fluorocarbon PTFE - Used for **seals and fittings** in some FMI pump head modules - excellent chemical resistance characteristics - soft, pliable, easily cut, nonstick surface chemically stable over wide thermal range, dimensionally sensitive to temperature change - not suitable for structural components.

Application Tips

PRESSURE: In most FMI pump models, motor starting torque is the limiting factor in the stated pressure rating. Fluids such as oils, creams and gels that are good lubricants are more easily pumped than aqueous or "dry" fluids and therefore require less motor torque and may be pumped against pressures considerably greater than those given in the rating charts.

All pump head components are designed to withstand backpressures up to 100 psig at room temperatures, though pump heads with fluorocarbon cylinder cases may exhibit some loss of pumping capacity at pressures over 60 psig.

ACCURACY: FMI pump accuracy is based on a simplified positive displacement mechanism. The valveless design provides an accuracy of better than 1% when handling medium viscosity fluids (50 to 500 centipoise). Aqueous solutions and light solvents work well but may exhibit some sensitivity (fluid slip) to variations in discharge head pressure. Gums, gels and non-abrasive semi-solids are handled with a high degree of accuracy... a direct result of the valveless design.

Viscous, tacky solutions, semi-solids and heavy slurries which tend to resist (cavitate) suction flow into a pump head can be handled with ease by selecting an FMI pump employing a relatively slow reciprocation rate.

The principal flow rate deviations of an FMI pump are fluid slip and stroke repetition rate. These two factors in turn are related to load factors such as viscosity, differential pressure, and drive motor voltage. When these two factors are controlled, the FMI pump will handle most fluids with reproducibility of better than 0.5%.

GAS PUMPING: Due to the valveless design of the FMI pump "CKY" and "CSY" pump heads are able to perform accurate gas transfers. With no valves to introduce random compression errors, gas sample flow in bagging, scrubbing and transit operation can be accurately preset based on actual piston displacement.







IMPORTANCE OF CLEAN FLUIDS: While a certain amount of caution must be exercised in the use of abrasive fluids in any metering pump, the "CKC" and "CSC" tend to be more tolerant of suspended solids than other metering pumps. To assure fluid compatibility, consult the Materials of Construction information above.

FOR BEST PUMPING RESULTS: Select an FMI PUMP having a maximum flow rating as near to the desired flow rate as possible.





Selection Guide for FMI's Pump Heads

	<p>QCKC Pump Heads offer excellent chemical resistance with most acids, caustics, and solvents (with the exception of acetone, methyl ethyl ketone (MEK), & methylene chloride). These pump heads are rated to 212 deg F, autoclaved to 240 deg F (non-operating), and for pressures to 60 psig.</p> <p>Fluid Path: Ceramic and PVDF fluorocarbon.</p>
	<p>QCKC-W "Gland" Pump Heads are identical to the above but include an extra pair of ports which provide an "isolation gland" for a barrier liquid or gas to isolate air sensitive, crystal-forming process fluids from atmosphere. Temperature & pressure as above.</p> <p>Fluid Path: Ceramic and PVDF fluorocarbon.</p>
	<p>QCSC Pump Heads offer excellent chemical resistance to almost all solvents. They have an extended temperature & pressure range of 350 deg F and 100 psig.</p> <p>Fluid Path: 316 SS, Ceramic and Teflon standard.</p>
 New	<p>QCSC-W "Gland" Pump Heads are identical to above but include an extra pair of ports which provide an "isolation gland" for a barrier liquid or gas to isolate air sensitive, crystal-forming process fluids from atmosphere. Process fittings are 1/4" NPT female; gland ports are 10-32 female.</p> <p>Fluid Path: 316 SS, Ceramic and Teflon standard.</p>
	<p>QSAN Pump Heads are designed for sanitary applications ideal for food, biotech, & pharmaceutical applications. These pump heads contain no internal threads, are highly resistant to chemical and biological attack, and are easily dismantled for cleaning and sterilizing. (Model QSAN-S shown)</p> <p>Fluid Path: Ceramic and Teflon standard.</p>
 New	<p>QCSC-TC "Tri-Clamp[®]" Pump Heads are designed for sanitary applications, in addition to having no internal threads, these pump heads have standard 3/4" sanitary quick-connect style fluid connections compatible with Tri-Clamp[®] fittings.</p> <p>Fluid Path: 316 SS, Ceramic and Teflon standard.</p>
 New	<p>QCSC-WT "Hi Temp Gland" Pump Heads are designed for applications, which require temperature control of the pump head. These pump heads provide space for two standard 1" x 1/4" cartridge heaters and a 1/8" thermocouple, as well as, an "isolation gland". Pump heads are rated for 350 deg F and 100 psig.</p> <p>Fluid Path: 316 SS, Ceramic and Teflon standard.</p>
	<p>RHLF "Low Flow" Pump Heads feature 1/4-28 female low dead volume ports as well as excellent chemical resistance. Designed for flows to 50 ml/min or dispenses 100 µl or less. RHLF pump heads are rated to 212 deg F, autoclaved up to 240 deg F (non-operating), and can be used in applications up to 100 psig.</p> <p>Flow Path: Ceramic and PVDF fluorocarbon standard - other materials available. RH00SKYLF, RH0CKCLF, H1CKCLF</p>
	<p>RH Pump Heads, 1/4" compression ports, and excellent chemical resistance to most acids, caustic, and solvents with some exceptions including acetone, methyl ethyl ketone (MEK), & methylene chloride. Designed for flows to 360ml/min. RH pump heads are rated to 212 deg F, autoclaved up to 240 deg F (non-operating), and pressure to 100 psig</p> <p>Flow Path: Ceramic and PVDF fluorocarbon standard-other materials available. RH00SKY, RH0CKC, RH1CKC</p>





ONE YEAR LIMITED WARRANTY

FMI LIMITED WARRANTY

FMI products are manufactured to a high level of mechanical precision from materials that are resistant to attack by many corrosive chemicals. These products, however, may be self-destructive when used with non-compatible fluids or when located in physically hostile environments or when operated under non-specification voltage or pressure conditions.

FMI, therefore, warrants only as follows:

Each pump has been test operated with water to rated pressure prior to shipment from the factory. The qualifying performance of each pump is recorded by serial number in a permanent record of the company. If at any time within the first 1 year after any FMI product has been shipped to a customer (user), it fails to perform according to FMI literature, the product, with written explanation of the problem, may be returned, freight prepaid, to the FMI plant for examination, repair or replacement at FMI expense (labor and material). All such returns must have prior FMI customer service authorization before returning. If, upon examination, FMI determines that abusive practices, non-compatible fluids or destructive environment of operation or a combination of these factors is responsible for improper performance of the product, all labor and materials costs involved shall be at the expense of the customer. All such returns shall be redelivered F.O.B. FMI factory.

FMI is not liable for special, indirect or consequential damages that may result from use, failure or malfunction of the product, and any recovery against FMI may not be greater than the purchase price paid for the product.

No person is authorized to change the terms of this warranty.

FMI TERMS AND CONDITIONS

PRODUCT STANDARDS

FMI products are certified and sold to comply with written FMI specifications. Only the corporation is authorized to modify product claims and specifications. Products are subject to change without notice.

RETURNS FOR CREDIT

Standard FMI catalog products under most circumstances, may be returned to the FMI factory for credit when still in unused condition, packed in original shipping cartons, and meets current product specifications. All such returns, must have prior FMI customer service authorization before returning. A restocking charge of 15% of original invoice price will be made on each to cover related restocking costs.

PRICES

Prices are subject to change without notice.

QUANTITY DISCOUNTS

Quantity discounts on standard catalog products purchased in units of ten or more are available. Contact FMI sales department for details.

QUOTATIONS

Prices quoted in writing will remain in effect for 30 days or any other time period stated in the written quotation.

MINIMUM BILLING

Minimum billing for FMI products is \$25.00 domestic and foreign invoice value per order, net of shipping costs and any applicable discounts regardless of price list value of order.

SHIPMENTS

Shipments are usually made within 24 hours of receipt of order.

F.O.B. SHIPPING POINT

All FMI prices are for delivery F.O.B. factory, Syosset, New York, packed for domestic shipment unless otherwise stated in writing.

FREIGHT POLICY

Provisions are made for pick-up, prepay and bill, or freight collect

delivery. All shipping costs other than those normal to FMI domestic product packaging and F.O.B. policy are incurred at customer request and expense. International orders are sent freight collect, unless otherwise specified.

FREIGHT CLAIMS

All claims for damaged merchandise should be made with the delivering carrier.

TERMS OF SALE PAYMENT TERMS

There are no provisions for financing of customer orders. Invoices are considered due and payable when presented.

International sales are cash in advance. Customers may establish an open account status by presenting FMI evidence of prompt payment history including: a) three general credit references, b) one or more bank references, c) Fluid Metering, Inc. reserves the right to obtain a credit report from a national reporting agency.

PROMPT PAYMENT DISCOUNT

1%, 10 days, net 30 for open account
Domestic sales – 2% cash with order

Prices are subject to change for payment terms other than those listed above.

FMI Customer Service Representatives and Technical Support Staff are available Monday through Friday from 8:00 am to 5:30 pm EST. You can also FAX your specifications 24 hours a day to 516-624-8261 or visit our internet site at: www.fmipump.com

WE have EDI at FMI - Give us a call.

We accept Visa, MasterCard and American Express





Components to Solutions

The Answer to All of Your Fluid Control Needs

PUMP HEADS

Variable Displacement

For applications which require frequent changes in dispense volumes or flow rates, FMI's selection of adjustable pump heads includes precision micrometer adjustment for ultra-fine control, even while running.

Fixed Displacement

Many processes and OEM instrumentation applications benefit from FMI's "set it and forget it" pumps. Once calibrated, fixed displacement pumps will maintain a precision of better than 0.5% for millions of cycles.

Special Applications

Special pump head designs and materials are available to meet your unique application requirements for Food, Pharmaceutical, Biotech, Industrial, and Process applications.



DRIVES & CONTROLLERS

Fixed Speed Drives

Ideal for General Purpose Laboratory, Industrial and OEM applications, FMI offers a full complement of fixed speed drives ranging from 6 RPM geared to 2300 RPM direct drive.

Variable Speed Drives

Provide extreme versatility for Industrial, Process Mobile, and Environmental Monitoring applications.

Stepper Motor Drives

Provide superior performance for Medical, Analytical, Industrial and OEM Instrumentation.

FMI 2008 SHOW SCHEDULE

FMI will demonstrate its full line of Metering Pumps, Dispensers and Accessories at the following Trade Shows:

Jan 27 - 29	Lab Automation	Palm Springs	CA	Booth 486
Jan 29 - 31	MD & M West '08	Anaheim	CA	Booth 1141
March 03 - 06	PITTCON '08	New Orleans	LA	Booth 4715
April 1 - 4	Analytica '08	Munich	Germany	Booth B2 251/7
April 22 - 23	NYSAWWA	Saratoga Springs	NY	Booth 71
July 29 - 31	AACC '08	Washington, DC	DC	TBA
August 18 - 20	ACS '08	Fall Philadelphia	PA	TBA
Sep 23 - 25	Ass'y Tech/Design & MD&M	Midwest Expo' 08	Chicago, IL	Booth 1236



5 Aerial Way, Suite 500 Syosset, NY 11791 USA
 Tel: 1-516-922-6050 Toll-free: 1-800-223-3388
 Fax: 1-516-624-8261