

## How a magnet drive works

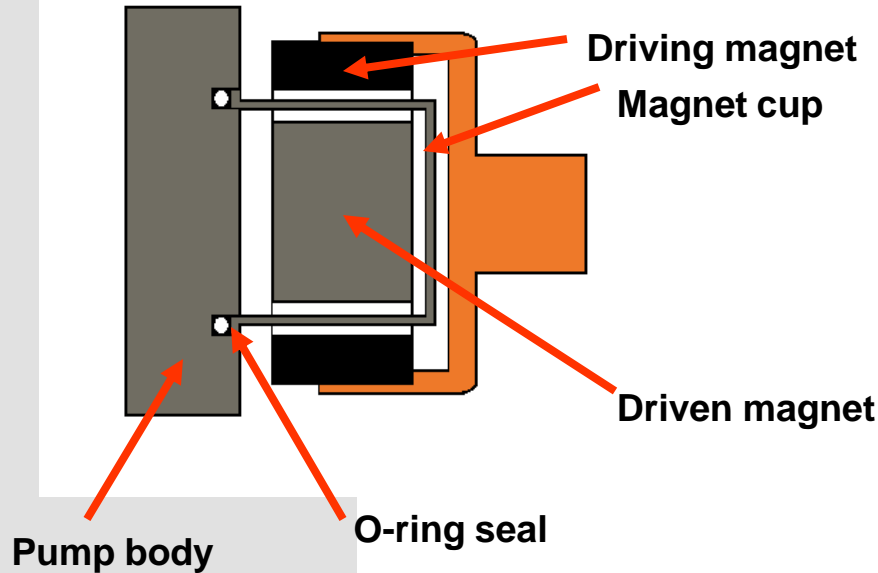

- Using a static seal greatly reduces maintenance and virtually eliminates the possibility of contamination or leakage.

- Magnetically coupled pumps utilise a static seal that is not subject to wear from moving parts.

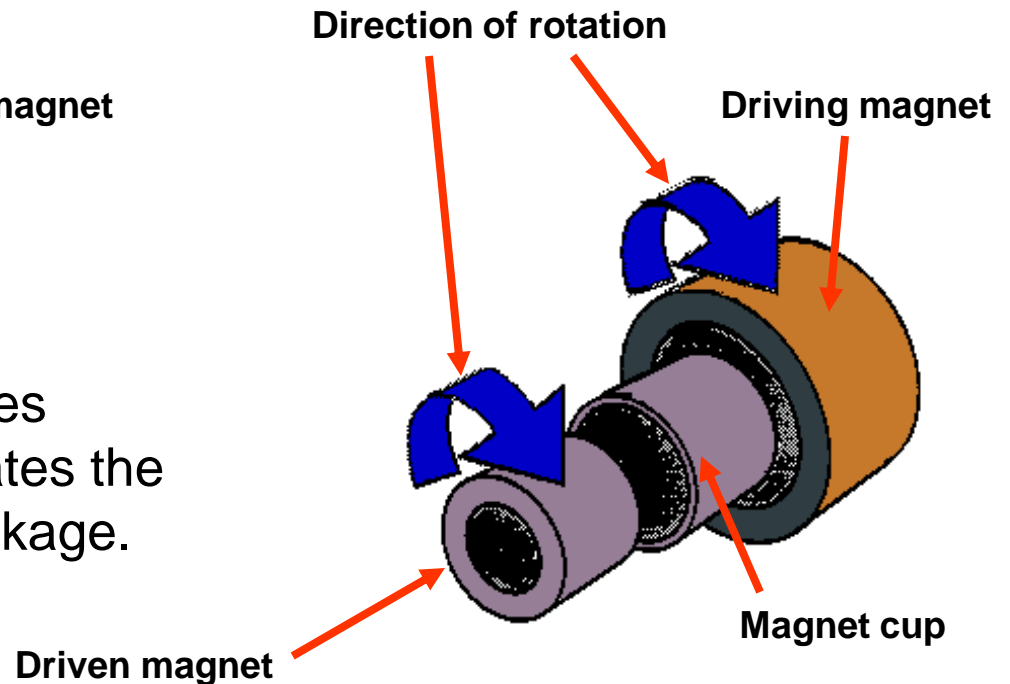

## Magnet Drive

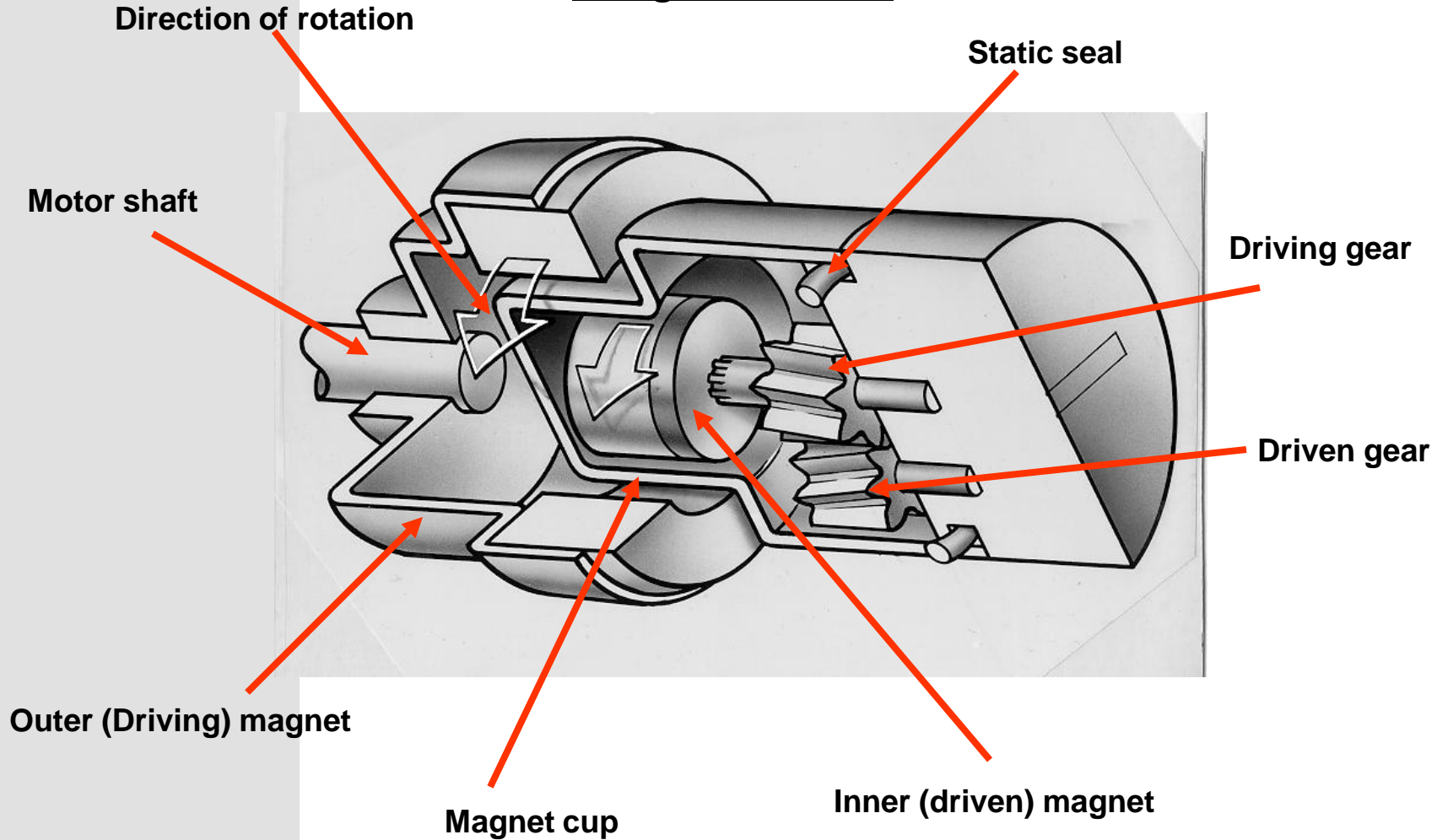

## Magnet Drive

- A straight bar magnet has two poles, North and South. Micropumps' annular (ring) magnets each have eight poles.
- These eight poles create eight sets of flux patterns. Different materials display different magnetic properties, the stronger the magnet the higher the number of flux lines per unit area.

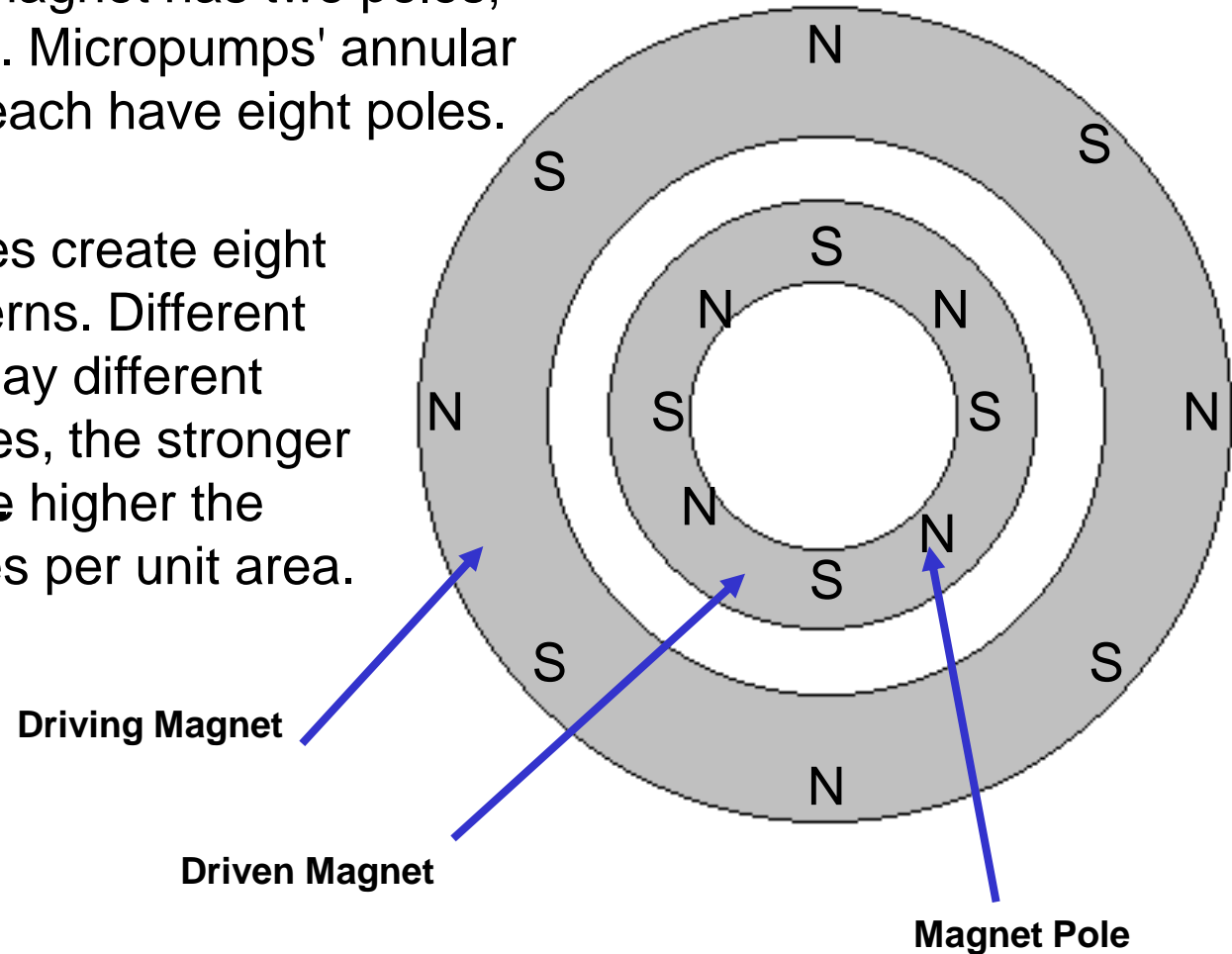

## Magnet Drive

- Magnet strength is measured in terms of “Flux Density”.
- When the driven magnet is placed inside the driving magnet these eight sets of flux patterns align themselves North/South, North/South, North/South etc. creating the magnetic coupling.

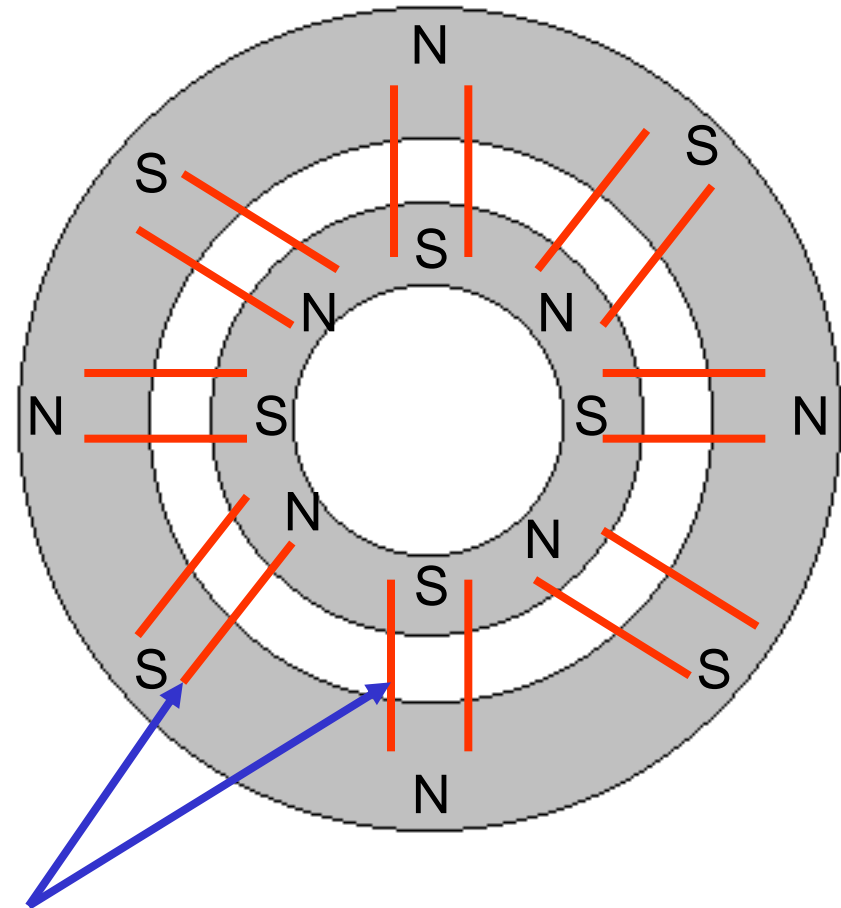

Flux lines

## Magnet Drive

<b>Material</b>	<b>Application</b>
<b>Barium Ferrite</b>	<b>Medium strength, Medium Temperature</b>
<b>Neodymium</b>	<b>High strength, Medium temperature</b>
<b>Samarium Cobalt</b>	<b>High strength, High temperature</b>

- Standard magnets are constructed from Barium Ferrite.
- It is possible to use, for example, a Samarium Cobalt driven magnet and a Barium Ferrite driving magnet.
- Neodymium and Samarium Cobalt are generally used in applications requiring high discharge pressures and/or extreme temperatures.

## Magnet Drive Strength

- Magnetic material is classified by its strength and is measured in terms of MegaGausse-Oersteads, or MGO:
  - Barium Ferrite has a strength of 1 MGO.
  - Neodymium has a strength of 10 MGO.
  - Samarium Cobalt has a strength of 26 MGO.
- Micropump purchases its Barium Ferrite and Neodymium material in an un-magnetised format, whereas Samarium Cobalt arrives pre-magnetised.
- Magnet coupling strength depends on driven/driving magnet combination.

## Magnet Drive

- Extreme temperatures will affect a magnets strength:
  - As a rough guide, magnetic strength decreases linearly with increasing temperature at a rate of roughly 0.2% per degree Celsius.
  - This means that a magnet coupling operating at 170 ° C will have 50% of the strength it had at room temperature.
  - Inversely the magnetic strength increases, but not linearly, at temperatures below ambient.
    - Thus, a pump re-circulating cold refrigeration fluid will have a higher decouple point than the same pump re-circulating high temperature oil.
  - As the temperatures return to ambient the magnets regain their original strength.
  - The Atomic structure changes at temperatures over 400°C, causing the magnet to demagnetise.

## Magnet Drive

- The magnetic attraction between the Driving and Driven magnets has a torque limit.
  - Magnet Decouple occurs when this torque limit is exceeded.
- The Decouple point is determined by magnet strength, but is influenced by temperature, fluid viscosity and system conditions.
- Magnet Decouple will result in total non performance of the pump whilst the motor appears to be operating normally.
- Once the two magnets Decouple they will not re-couple until the driving magnet is brought to a complete stop. The two magnets will then automatically align and re-couple.