

High performance series

Micro annular gear pump mZR[®]-11508

For industrial production and process technology

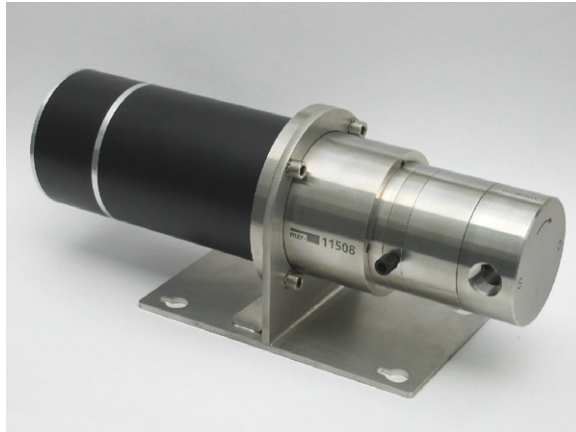

- **High dosage precision**
precision CV < 1% at low volumes
- **Long service life**
wear-resistant tungsten carbide
- **Broad viscosity range**
methanol, water, solvents, adhesives, grease, gel
- **Dynamic precision motor**
brushless DC-motor with encoder
- **Compact measurements**
length 309 mm
- **High differential pressures**
achievable even for low viscosity liquids
- **Pulseless delivery, low shear stress**
rotary micro annular gear technology

The micro annular gear pump mZR-11508 is equipped with tungsten carbide rotors and bearings. Hard construction material and precision manufacturing techniques guarantee excellent dosage precision, high service life and

wear resistance for low volume dosage of non-lubricating liquids. Driven by a high-power DC-motor the pump has a compact design and covers the flow range from 0.19 ml/min to 1152 ml/min. The mZR-11508 is suitable for contin-

uous delivery and discrete dosage of low and high viscosity liquids. It achieves high differential pressures and provides a pulseless flow. Its robustness and the available accessories make it suitable for challenging applications.

Applications

- Chemical processing
- Industrial and plant engineering
- Packaging
- Medical and pharmaceutical industry
- Mini plant technology
- Spraying
- Dispensing of adhesives
- Ink and paint dosage
- Vacuum applications

Technical data

Flow rate	0.19 – 1152 ml/min
Smallest dosage volume	100 µl
Displacement volume	192 µl
Differential pressure range	0 – 60 bar (870 psi), 0 – 150 bar * (2175 psi *)
Max. inlet pressure	10 bar (145 psi)
Operating temperature range	-5 ... +60 °C (-20 ... +120 °C **)
Viscosity range	0.3 – 150,000 mPas
Precision	< 1 % Coefficient of Variation CV
Pulsation	< 6 %
Speed range	1 – 6000 rpm
Fluid connection	3/8" NPT internal thread, lateral optional 3/8" NPT internal thread, frontal
Wetted parts	stainless steel 316L (1.4435), tungsten carbide Ni-based; shaft seal: graphite-reinforced PTFE, alloy C276 (2.4819); static seals: FPM, optional: EPDM, FFPM
Motor	brushless DC-motor, IP 54, 42 V DC, max. 368 W
Encoder	500 counts per turn, type HEDL 5640
Interface	motor cable length 3 m, 6-pole plug for motor winding, 12-pole plug for encoder and hall sensors
Measurements (L x B x H)	309 x 108 x 124 mm
Weight	approx. 8 kg

Customized solutions on request.

* for viscosity > 16 mPas

** with optional heat insulation module, heating module

Contact

HNP Mikrosysteme GmbH
Juri-Gagarin-Ring 4 · D-19370 Parchim

phone +49| 3871| 451-301
fax +49| 3871| 451-333

e-mail info@hnp-mikrosysteme.de
<http://www.hnp-mikrosysteme.de>

Measurements

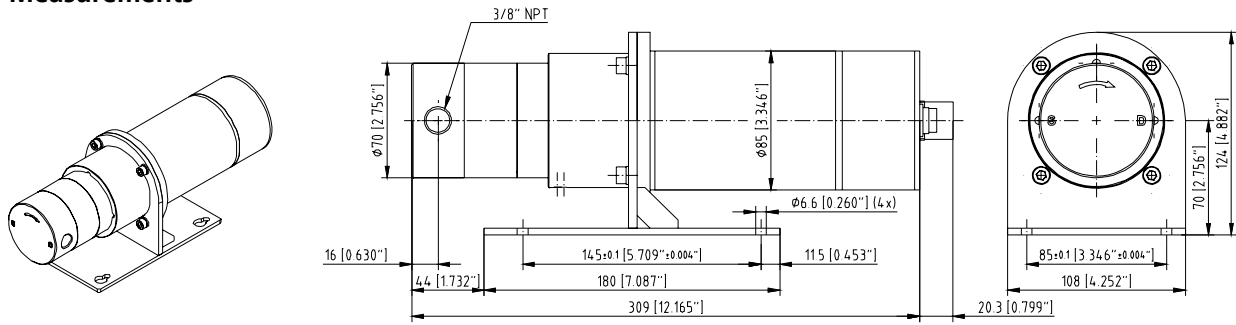

Subject to technical changes.

Flow charts

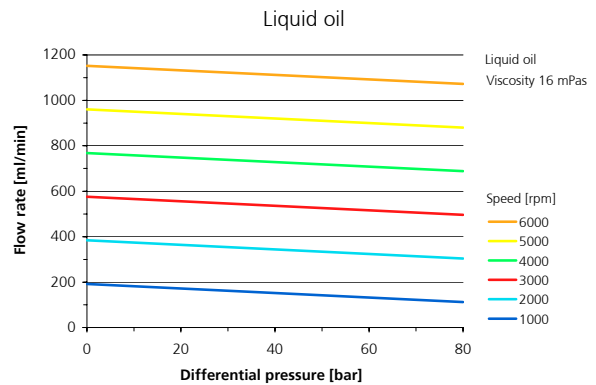
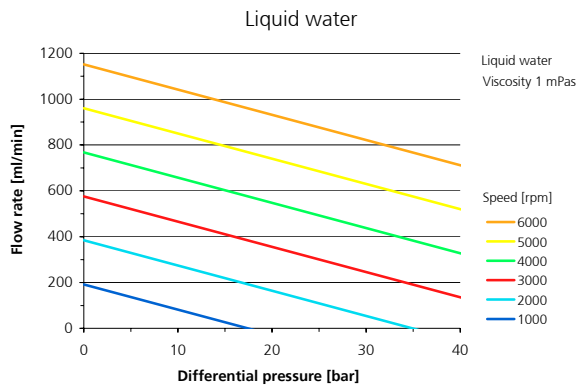

Control and software



- speed control S-HV for continuous delivery tasks
- servo-amplifier in a rugged aluminum case
- supply voltage 11–70 V DC, nominal current up to 10 A (optional max. current 20 A)

- speed range 10 – 6000 rpm
- internal potentiometer for speed control (optional external potentiometer)
- item no. 66 03 01 01



- speed and position control S-HP for continuous and discrete dispensing tasks
- servo-amplifier in a rugged aluminum case
- supply voltage 11–70 V DC, nominal current up to 10 A (optional max. current 20 A)

- speed range 1 – 6000 rpm
- standard interface: RS-232, CAN
- operating system EPOS
- 4 digital inputs 24 V DC
- 4 digital outputs 24 V DC
- item no. 66 04 01 03

Item number

10 03 01 37

mzr-11508 S pump with brushless DC-motor, lateral fluid connection 3/8" NPT

Accessories

Liquid supply accessories
Fluidic seal module
Heat insulation module
Heating module

threaded fluid connectors, tubes, filters etc.
use of liquids sensitive to air or water or for vacuum applications
use for increased liquid temperature up to 120 °C
active heating of the pump head up to 120 °C operating temperature

Micro annular gear pumps (and housings) are protected by assigned patents: DE 198 43 161 C2, EP 1115979 B1, US 6,520,757 B1, EP 852674 B1, US 6,179,596 B1, EP 1354135. Patents pending: DE 101 46 793, US 10,466,792, DE 10 2004 052 866. In the US, Europe and Japan additional patents are pending.
mzr® is a registered German trademark of HNP Mikrosysteme GmbH.