

# E MONITOR

**Design:**

- 1 Shaft
- 2 Winding
- 3 Probe
- 4 Bearing
- 5 Shaft sleeve
- 6 Thrust washer

 Liquid

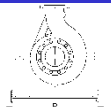
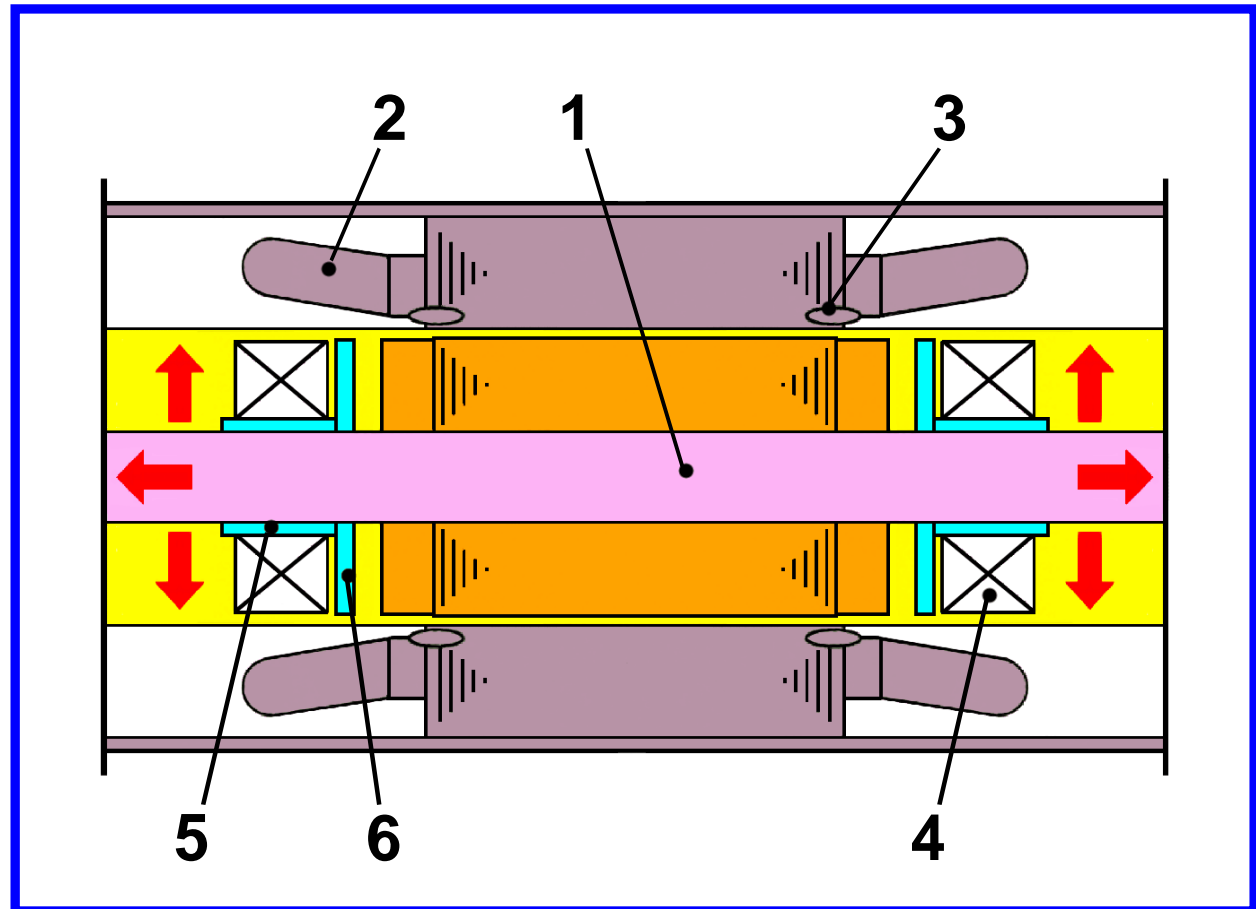

# NIKKISO E MONITOR

— GOOD — CAUTION STOP

AXIAL

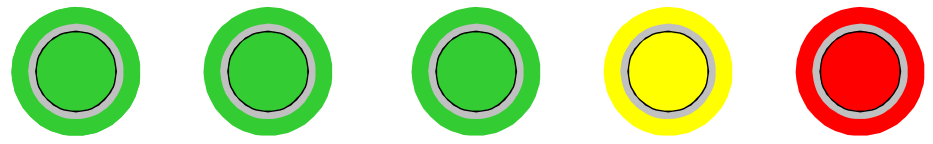

RADIAL

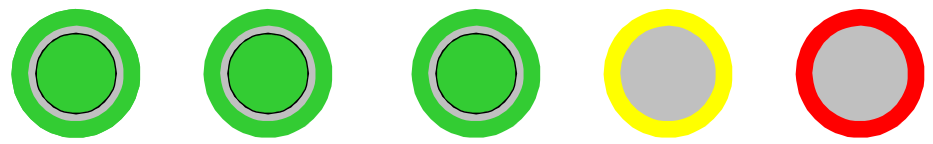

POWER

REV.

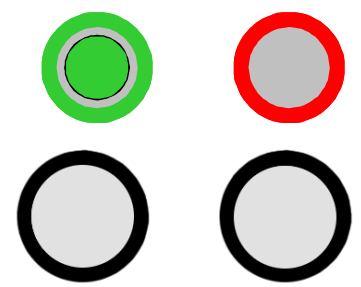

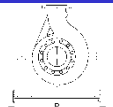
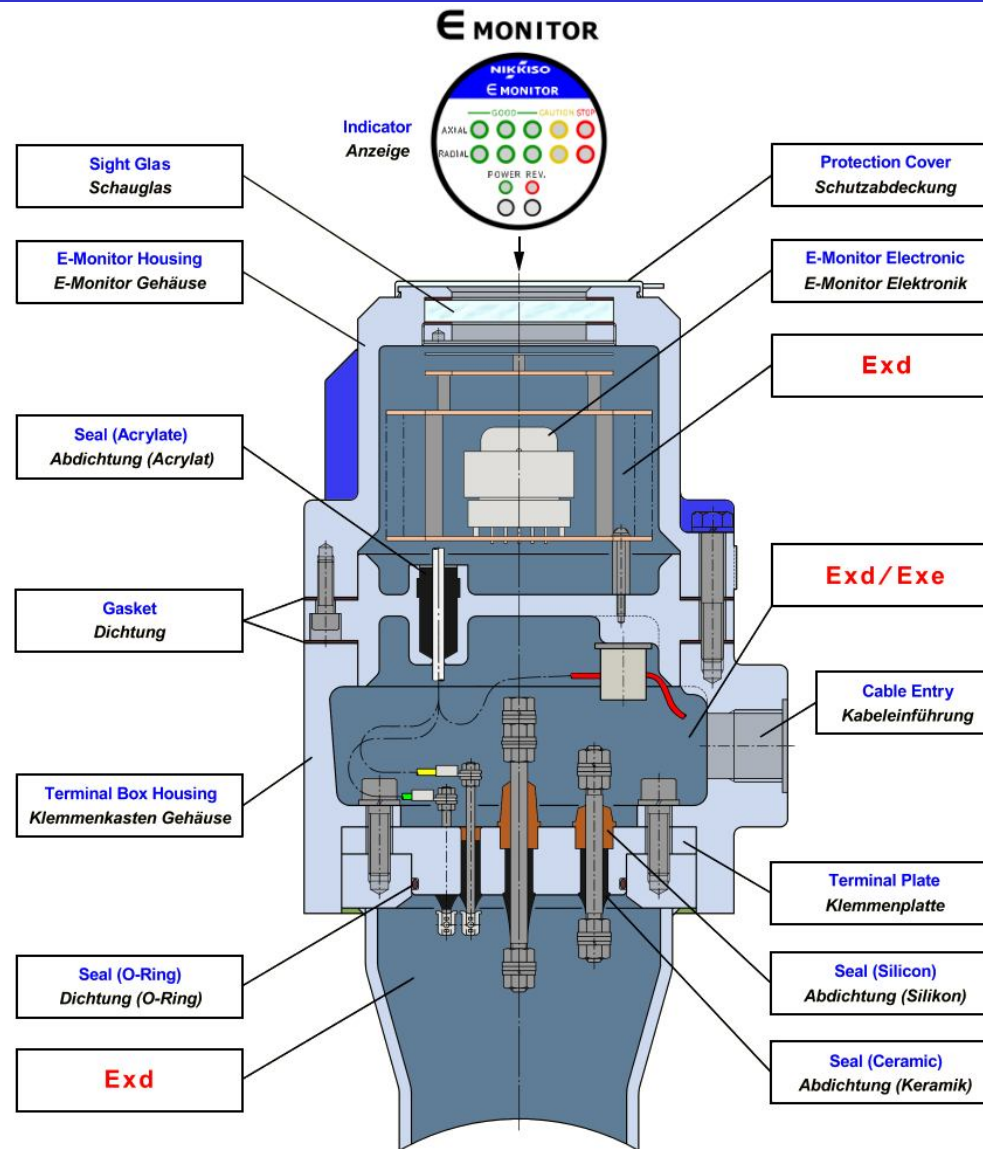

LOCAL INDICATION

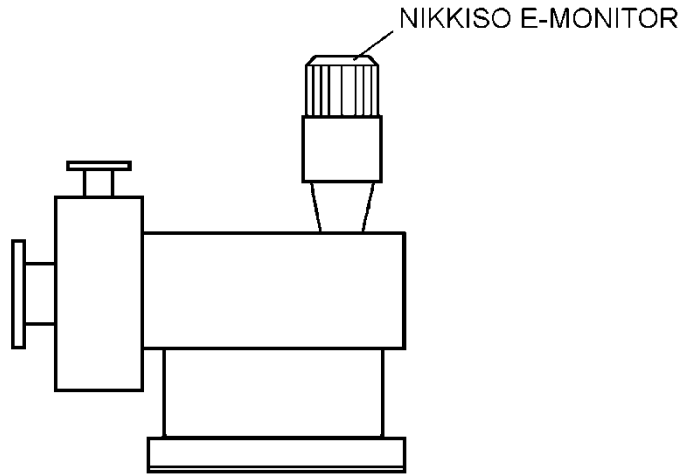

LOCAL AND REMOTE INDICATION

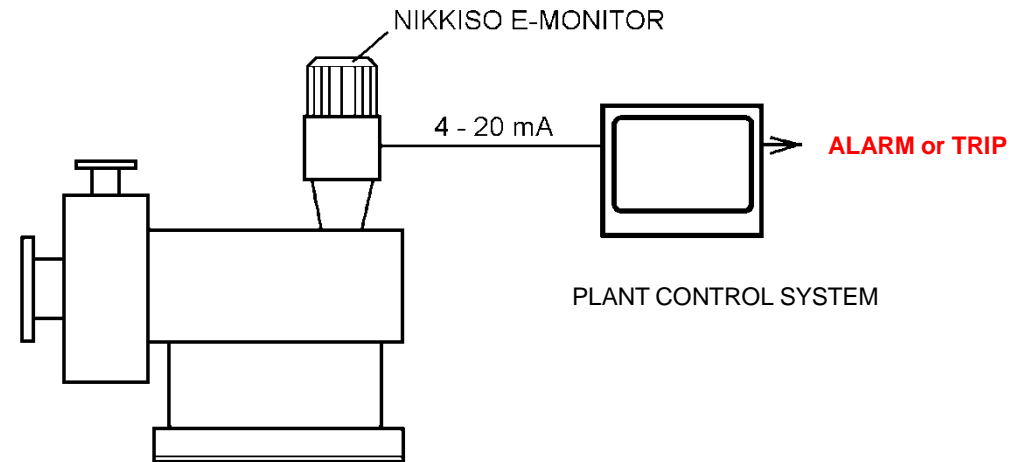
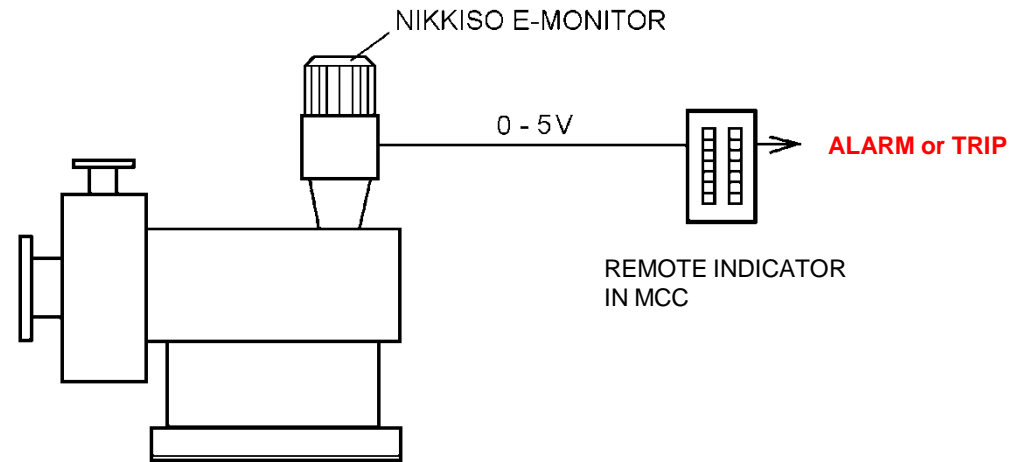

The E-monitor helps the customer ...

- plan maintenance of the pumps
- prevent costly pump failures
- avoid un-scheduled down time
- increase the operational reliability of the plant

