

Canned Motor Pump

HY - Series

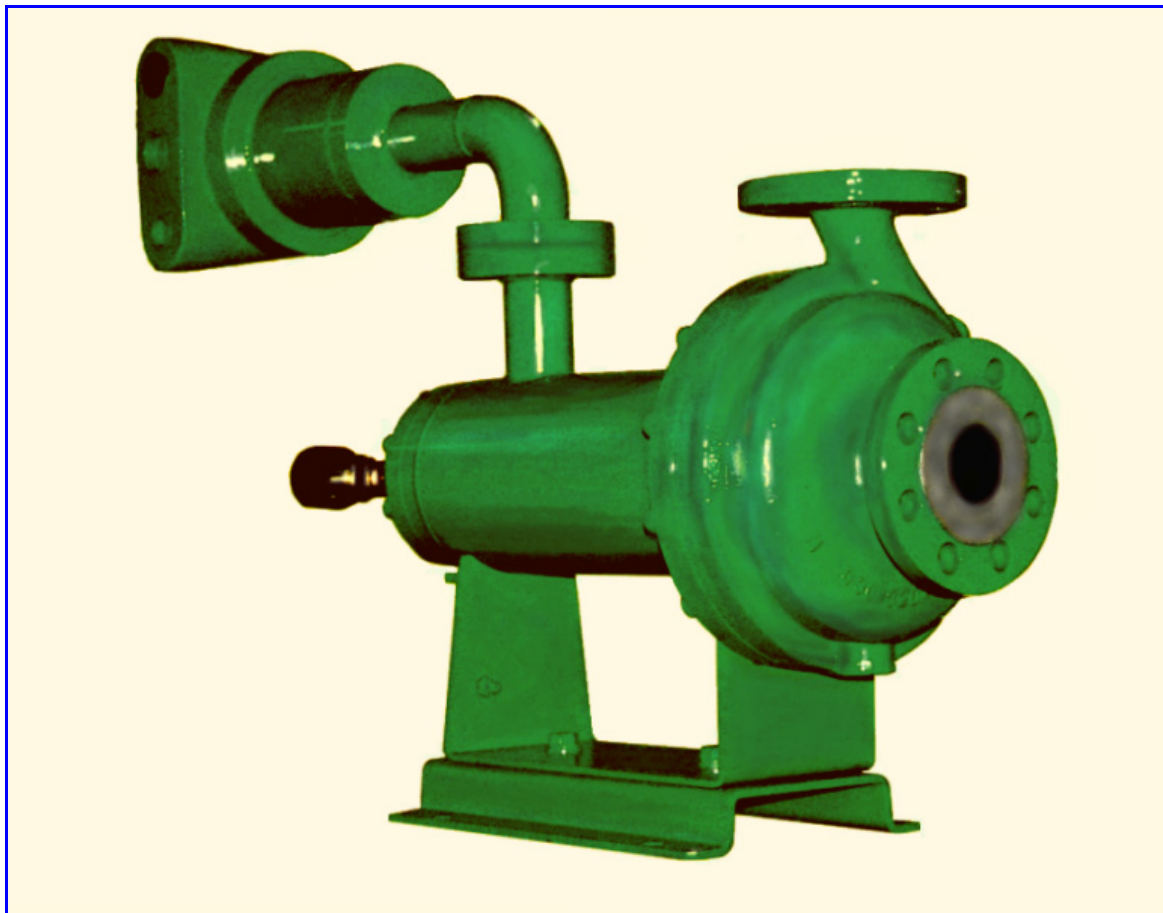

High temperature liquids - No cooling required



Capacity	max. 130 m ³ /h
Head	max. 90 m
Motor rating	max. 7,5 kW
Medium temperature	max. 250 °C

General HY - Series

Nikkiso HY-Series canned motor pumps are centrifugal pumps, which are due to their construction without shaft seals. The pumps are driven by integrated canned motors.

Space requirements and noise emissions are much lower than those of conventional centrifugal pumps.

The HY-type is designed for hot fluid application up to 250°C. without external cooling.

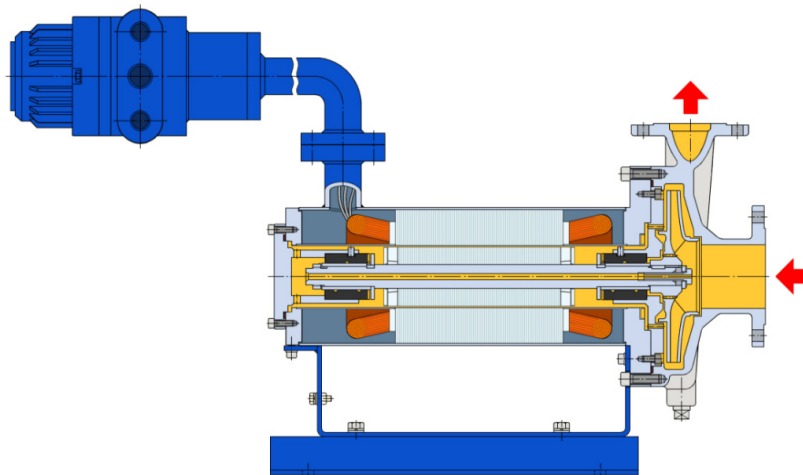

- Compact size
- Axial thrust balanced for long bearing life
- Bearing wear monitoring
- For liquid temperatures up to 250°C no external cooling required
- Nikkiso block building system
- Heating jackets for pump / motor available
- Spare parts interchangeable with SGM-Series

Applications:

Nikkiso HY - Series canned motor pumps are mainly used for aggressive, inflammable, explosive and toxic clean liquids at high temperatures and offers advantages over conventional pumps when pumping water.

The pumps are proven for use in vacuum systems.

The pumps are used for

- Hot water up to 200 °C
- Heat transfer liquids also offers advantages over conventional pumps when pumping water.
- Solidifying liquids (solidifying point to 160°C)

Pressure / Capacity Envelope

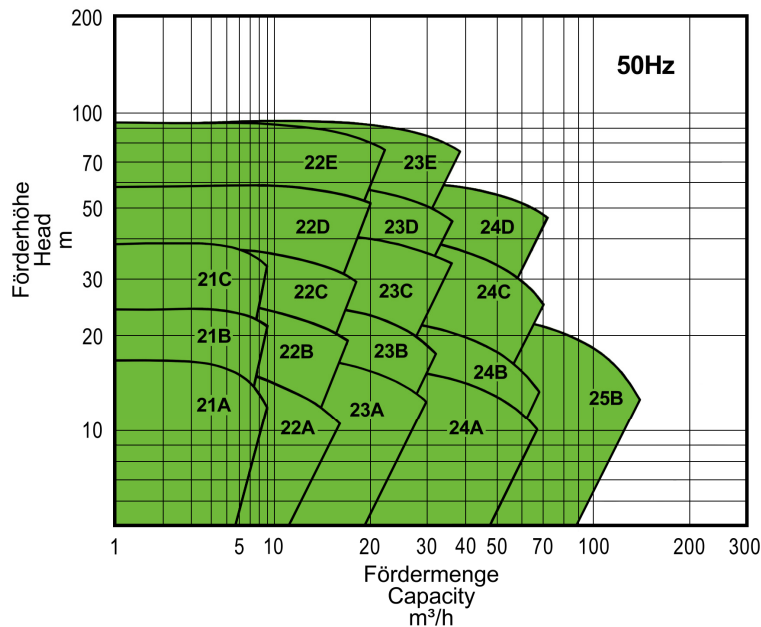

Materials (Standard design)

Part	Code
Casing(s)	1.4408
Impeller	1.4408
Gaskets	1.4401 / Graphite spiral wounded
Bearing housing	1.4401
Bearing	Special Carbon or with Silicium Carbide coated bearing surface
Shaft sleeves	1.4401 / Metco
Thrustwasher	1.4401 / Wolfram carbide 1.4401 / Chromoxide
Motor housing	1.0040
Stator shell	1.0040
Can	Hastelloy
Rotor/Stator end cover	1.4401
Base / Motor support	1.0040

Other materials on request

Driver

- Integral 3-phase asynchronous motor IP66 and Explosion Protection acc. to Directive 94/9/EC (ATEX 95)
- The motors are in accordance with VDE/EN requirements.
- Thermal winding protection