

H12R SEALED H12R-MC MAG-DRIVE

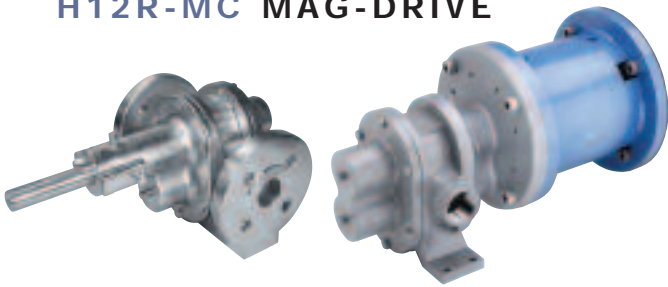

H-SERIES
GEAR PUMP



Sealed,
Long-Coupled

Sealed or Mag-Drive,
Close-Coupled

PERFORMANCE CURVES

1 CPS Fluid (Water)

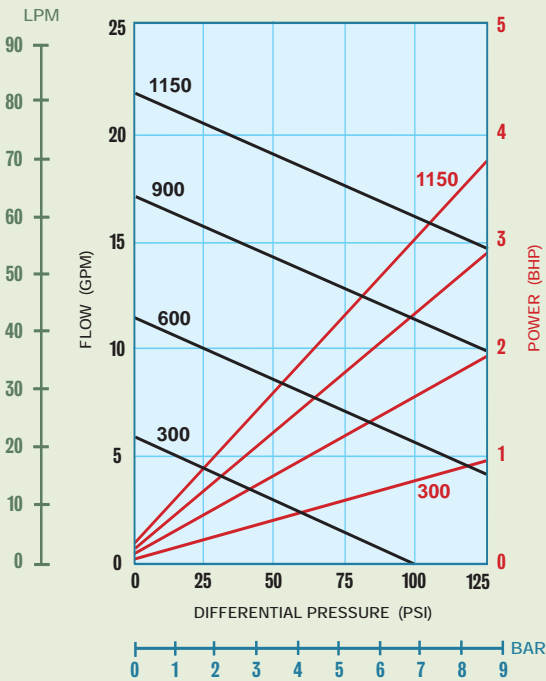

100 CPS Fluid (Oil)

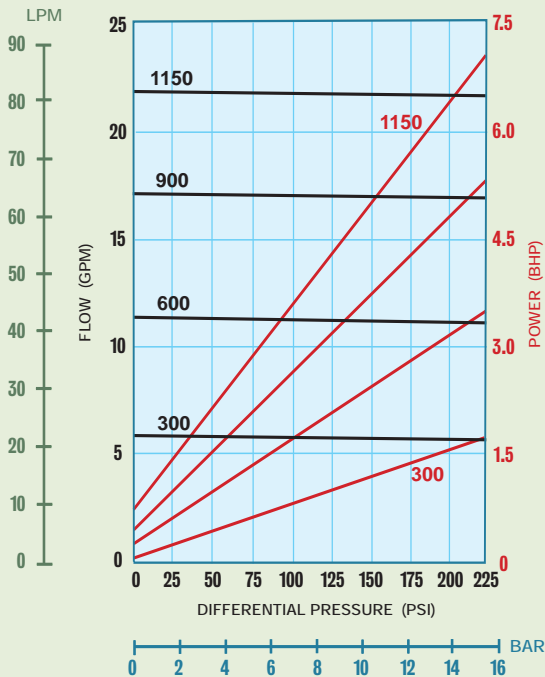

| | |
|-------------------------------|-------------------------------|
| PORT SIZE | 1 1/2" FLG or 1 1/4" NPT/BSPT |
| MAX FLOW | 22 GPM; 83 LPM |
| MAX DIFFERENTIAL PRESSURE | 225 PSI; 15.5 BAR |
| MAX DISCHARGE PRESSURE | 270 PSI; 18.6 BAR |
| MAX TEMPERATURE | 500°F; 260°C |
| MIN TEMPERATURE | -40°F; -40°C |
| MAX VISCOSITY | 100,000* CPS |
| NPSHR @ 1150 RPM | 5 FT; 1.5 M |
| LIFT (DRY) | 15 FT; 4.5 M |
| WEIGHT (without motor) | |
| SEALED, Long-Coupled | 52 LBS; 24 KGS |
| SEALED, Close-Coupled | 77 LBS; 35 KGS |
| MAG-DRIVE, Close-Coupled | 95 LBS; 43 KGS |

* Higher viscosities possible. Contact factory.

Dimensional Data (inches)

H12R Sealed, Long-Coupled

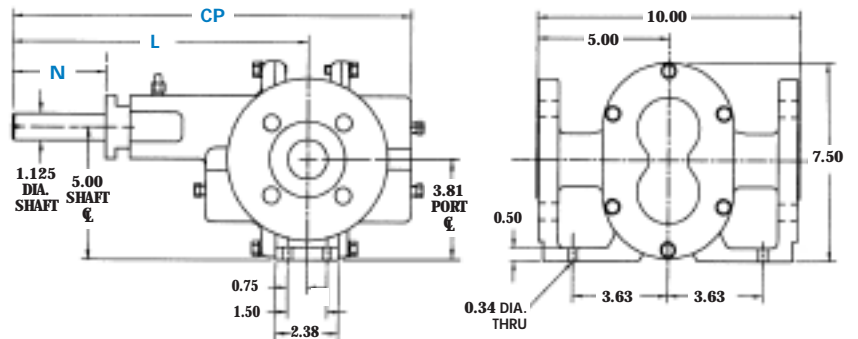

| DIMENSION | SEAL CONFIGURATIONS | |
|-----------|----------------------------------|----------|
| | SINGLE & DOUBLE MECHANICAL SEALS | PACKING |
| CP(1) | 13.69 | 13.69 |
| L | 9.75 | 9.75 |
| N | 2.56 | 2.28 (2) |

NOTES: (1) Add .31 inches for Bearing Flush Plugs.
(2) Minimum dimension.

Dimensional Data (inches)

H12R-MC & H12R Sealed, Close-Coupled

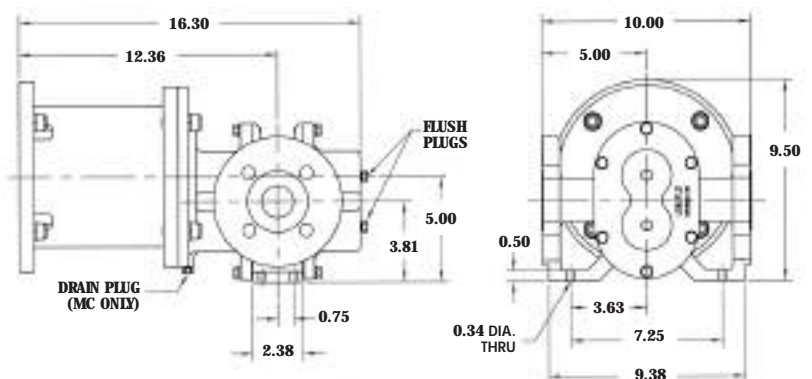



OFFICIAL DISTRIBUTORS FOR:

**VIKING
PUMP**

A Unit of IDEX Corporation

Viking Gear Pumps

Liquiflo 

Liquiflo Gear Pumps



FINISH THOMPSON INC.

Finish Thompson Drum & Centrifugal Pumps



Codip Air Operated PTFE Diaphragm Pumps

MICROPUMP

Micropump Gear Pumps

HNP M

HNP Mikrosysteme

HNP Gear Pumps

WANNER
Hydra-Cell
Seal-less Pump Technology

Hydra-Cell High Pressure Diaphragm Pumps



M Pumps, Centrifugal,
Turbine and Vane Pumps

ISMATEC

Ismatec Peristaltic Pumps

 **FLUID** METERING, INC.

Fluid Metering Piston Pumps

