

KC Series

SEALLESS CENTRIFUGAL PUMPS



Superior design – Only one of many FTI advantages

Diseño superior – Solamente una de muchas ventajas del FTI

FTI Design Advantages

The superior FTI design offers many performance advantages over traditional ceramic mag pumps. The unique application of small rare earth magnets, carbon bushings, and spindle design contribute to an unmatched extended run-dry capability. The cantilevered design of the ceramic spindle provides added impact resistance reducing breakage, friction losses, and heat build-up. Rugged polypropylene or PVDF housings provide excellent chemical and corrosion resistance.

Rare-Earth-Magnet Advantages

Neodymium rare-earth magnets increase pump operating life. Incredible magnetic power handles high specific gravity with no impeller trimming. Smaller magnet size allows a lighter weight rotating impeller while increasing performance. FTI rotating parts are 1/7th the weight of conventional ceramic magnetic pumps.

User Advantages

The integrity of FTI’s magnetic technology application, coupled with expert thermoplastic mold engineering, provides reliable, uninterrupted pump performance unachievable in ceramic mag pumps. Extended run-dry capability, decreased downtime, and product reliability are sound economic advantages for KC Series users.

Ventajas del Diseño de FTI

El diseño superior de las bombas FTI ofrece muchas ventajas sobre las bombas centrifugas de acople magnético. Las carcasas de polipropileno o PVDF son robustas y proporcionan una excelente resistencia a la corrosión de muchos productos químicos. La singular utilización de pequeños imanes de Tierras Raras, bujes de carbón y el diseño de la flecha, contribuyen para proporcionar una inigualable capacidad para funcionar en seco por más tiempo. El diseño del eje de cerámica le da una resistencia adicional al impacto, reduciendo el riesgo de ruptura las pérdidas por fricción y el incremento de la temperatura.

Ventajas de Los Imanes de Tierras Raras

Los imanes de Tierra Raras incrementan la vida útil de la bomba. Esta increíble fuerza magnética maneja fluidos de alta gravedad específica sin necesidad de recortar los impelentes. El tamaño reducido de los imanes permite tener un impelente rotatorio de peso ligero incrementando la eficiencia. Las bombas FTI pesan la séptima parte de lo que pesan las bombas con imanes de cerámica convencionales.

Ventajas para el Usuario

La utilización integral de la tecnología magnética de FTI, en combinación con la experta ingeniería de termoplásticos moldeados, aseguran el funcionamiento confiable e ininterrumpido de la bomba; inalcanzable en las bombas magnéticas tradicionales. La incomparable seguridad de la bomba, con la confianza adicional de poder trabajar la bomba en seco por más tiempo, disminuye las interrupciones en la operación y ofrece beneficios económicos importantes a los usuarios de las bombas de la serie KC.

Rare-Earth Magnets

Los Imanes de Tierras Raras

-  Neodymium
-  Samarium Cobalt
-  Alnico (Ceramic)
-  Ferrite (Ceramic)
-  Steel
-  Lode Stone

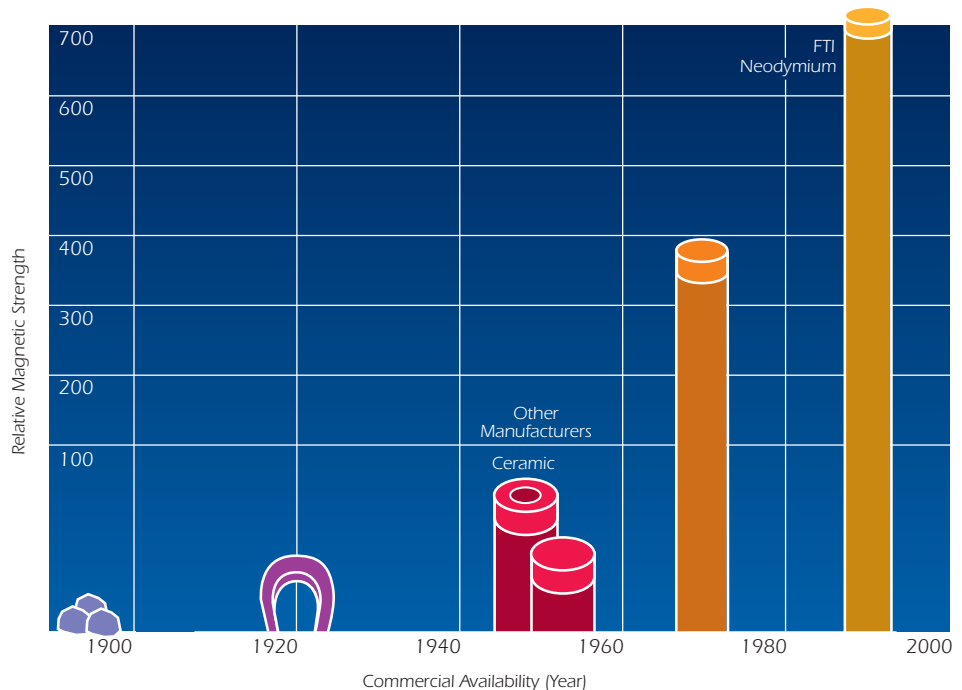

KC Series Sealless Centrifugal Pumps

1/8 to 1 HP

Bombas de la Serie KC Centrifugas (sin Sello)

1/8 a 1 HP
.06 a .75 kW



KC3/4/5
PP



KC3/4/5
PVDF

*Also available:
KC3 open drip proof motor



KC5.5/6/6H
PP



KC7/8
PP



KC10
PP



KC5.5/6/6H
PVDF



KC7/8
PVDF



KC10
PVDF

KC Series Sealless Centrifugal Pumps

1-1/2 to 10 HP

Bombas de la Serie KC Centrifugas (sin Sello)

1-1/2 a 10 HP
1.1 a 7.5 kW



KC11
PP



KC22
PP



KC32
PP



KC11
PVDF



KC22
PVDF



KC32
PVDF

KC Series Features

Características de la Serie KC

*Also available in multi-stage and vertical models.

†with carbon bushing (con el buje del carbón)

Features*

- Run dry capability 24 hrs. or more for KC5.5 through KC11, 10 minutes for KC22/32. Under a minute for KC3, 4, 5.†
- Specific gravities to 1.8
- Accepts standard NEMA 56C, 145TC, 184TC, 213TC or IEC metric motors (excludes KC3, 4 & 5)
- Modular design for component interchangeability
- Unmatched coupling strength
- Chemical resistant polypropylene or PVDF materials
- No environmental contamination
- Discharge port o-ring available on selected models
- Temperatures: PP – 180°F (82°C)
PVDF – 220°F (104°C)

Características*

- La capacidad seca del funcionamiento es 24 horas o más para KC5.5 por KC11, 10 minutos para KC22/32. Bajo minuto para KC3, 4 y 5.†
- Gravedades específicas de hasta 1.8
- Pueden acoplarse a motores NEMA 56C, 145TC, 184TC, 213TC o métricos IEC (excepto KC3, 4 & 5)
- Diseño modular para intercambiabilidad de componentes
- Fuerza de acoplamiento magnético incomparable
- Materiales resistentes a productos químicos, polipropileno o PVDF
- No contaminan el medio ambiente
- Anillo en la descarga disponible en algunos modelos
- Temperaturas de operación:
PP – 82°C (180°F)
PVDF – 104°C (220°F)

Performance Curves

Curvas de Funcionamiento

KC 3, 4, 5

- Maximum 24 to 31 ft. head (5.0 to 6.5 m)
- Maximum 13.5 to 16.2 gpm flow (2.4 to 3.1 m³/hr)
- Maximum 1.8 sg

KC 5.5, 6, 6H, 7, 8, 10

- Maximum 37 to 55 ft. head (7.8 to 11.8 m)
- Maximum 31 to 69 gpm flow (5.7 to 12.6 m³/hr)
- Maximum 1.8 sg

KC 11, 22, 32

- Maximum 33 to 151 ft. head (7 to 32.6 m)
- Maximum 53 to 241 gpm flow (9.6 to 43.8 m³/hr)
- Maximum 1.8 sg

KC 3, 4, 5

- Altura máxima 5.0 a 6.5 m
- Caudal máximo 2.4 a 3.1 m³/hr
- Gravedad específica máxima 1.8

KC 5.5, 6, 6H, 7, 8, 10

- Altura máxima 7.8 a 11.8 m
- Caudal máximo 5.7 a 12.6 m³/hr
- Gravedad específica máxima 1.8

KC 11, 22, 32

- Altura máxima 7 a 33 m
- Caudal máximo 9.6 a 43.8 m³/hr
- Gravedad específica máxima 1.8

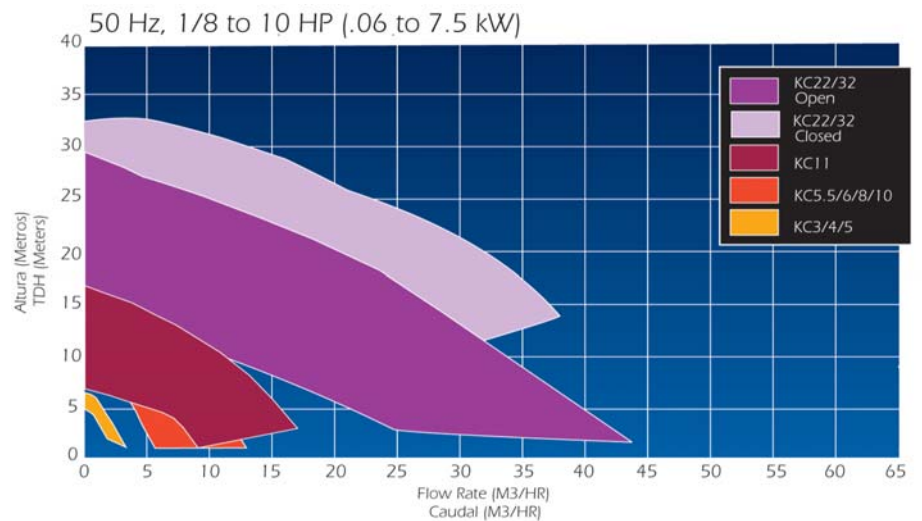
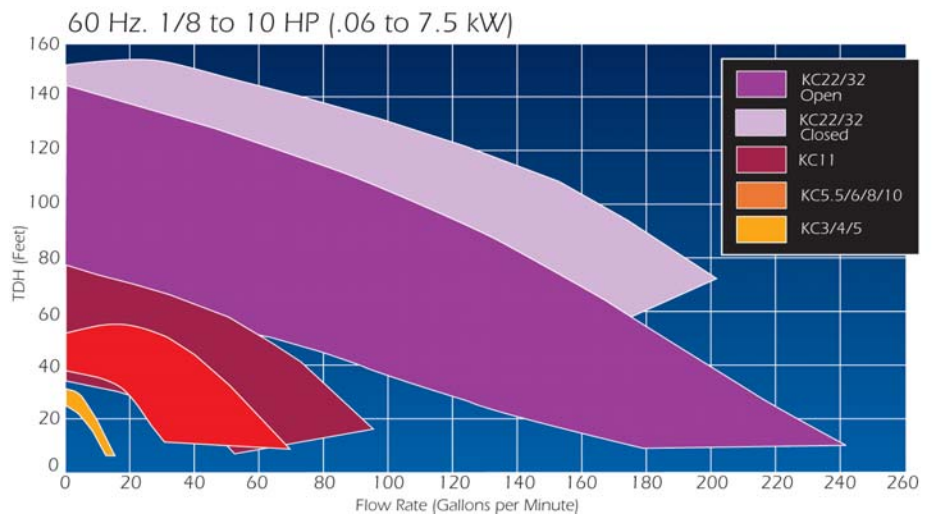

Typical Pump Components

Componentes Típicos de la Bomba

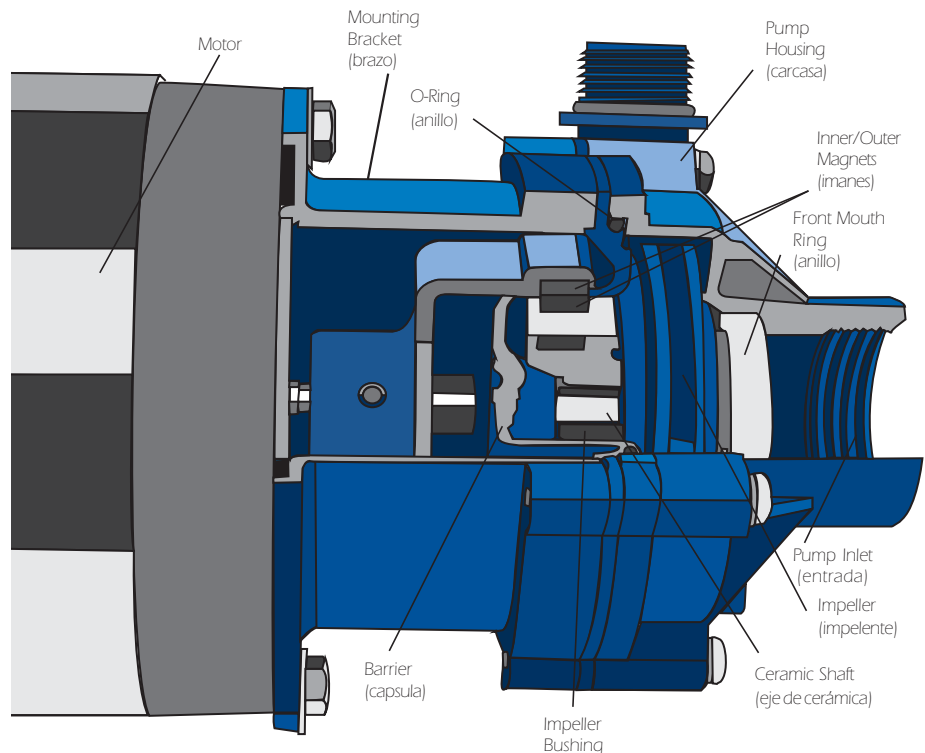

FINISH THOMPSON INC.

921 Greengarden Road • Erie, PA 16501-1591 U.S.A.
Ph 814-455-4478 • Fax 814-455-8518

Email fti@finishthompson.com • www.finishthompson.com

Toll Free USA & Canada 1-800-934-9384

Literature ID No. FT97-620I, 1-19-04



OFFICIAL DISTRIBUTORS FOR:

**VIKING
PUMP**

A Unit of IDEX Corporation

Viking Gear Pumps

Liquiflo 

Liquiflo Gear Pumps



FINISH THOMPSON INC.

Finish Thompson Drum & Centrifugal Pumps



Codip Air Operated PTFE Diaphragm Pumps

MICROPUMP

Micropump Gear Pumps

HNP M

HNP Mikrosysteme

HNP Gear Pumps

WANNER
Hydra-Cell
Seal-less Pump Technology

Hydra-Cell High Pressure Diaphragm Pumps



M Pumps, Centrifugal,
Turbine and Vane Pumps

ISMATEC

Ismatec Peristaltic Pumps

 **FLUID** METERING, INC.

Fluid Metering Piston Pumps

