



**DICKOW  
PUMPEN**



**Centrifugal Pumps with Shaft Sealing  
and Priming Stage**

**Type HZS / HZSA**

## General

The selfpriming multistage DICKOW-centrifugal pump is designed for handling hydrocarbons and other volatile liquids.

## Applications

The HZS-type is used in tank farms, for offloading of rail cars and trucks, filling of storage tanks, feeding hydrant systems on air fields and for other applications where priming of empty suction pipes is required.

The HZSA-type with low NPSH-requirements and gas handling capability is developed for pumping liquified petroleum gas (LPG). Typical application is the filling of LPG-trucks in refineries.

The performance range is subdivided to achieve best efficiencies for all service conditions.

With a wide selection of materials and the possibility of applying several shaft sealing systems as well as a hermetically sealed permanent magnetic coupling, the HZS/HZSA-pumps are suitable for handling almost all kinds of liquids which are free of abrasive solids and of suitable viscosity.

## Hazardous area

Together with the required Ex-drive motors, the HZS/HZSA-pumps can be applied in hazardous area Group II, Category 2. The pumps meet the basic safety and health requirements of Explosion-proof Directive 94/9 EC and are suitable for plants with increased safety requirement.

## Construction

HZS/HZSA-pumps are single or multistage horizontal centrifugal pumps, combined with integrated gas-handling resp. selfpriming side channel stage on the discharge side.

## Suction- and discharge casing

The pump flanges of HZS-pumps are provided generally in vertical top position to grant a certain quantity of liquid in the pump which is necessary for priming empty suction pipes and lifting pumpage from under ground storage facilities. To obtain low NPSH-values, the suction casings of the HZS-pumps are designed as inlet spirals with a nominal flange diameter one size larger than the discharge casings.

Suction and discharge casing are provided with sturdy feet for mounting on base plate.

The HZSA-pumps, used for applications with suction liquid level above pump centerline, have end suction design to obtain lowest NPSH-values.

## Impellers

The closed impellers are hydraulically balanced by wear ring gaps and balance holes, the anti-friction bearings are carrying only minor loads and further balancing devices are not necessary. For lowest NPSH-values, the impeller of the first stage is designed as a suction impeller with enlarged impeller eye.

## Bearing

The HZS-pump shaft is carried by generously dimensioned grease-lubricated double-row angular ball bearings and a roller bearing, located outside the pumped liquid. These bearings can be regreased through grease nipples, provided in the bearing cover.

The HZSA-pumps are provided with a Silicon Carbide sleeve bearing on the suction side which is - to avoid dry running - connected to the discharge side.

## Wear rings

Suction- and discharge casings, intermediate casings and diffusers are generally equipped with interchangeable wear rings. If requested, the pumps can also be equipped with impeller and casing wear rings.

## Priming stage

The side channel stage is capable to evacuate the suction line and therefore to selfprime if initially filled with operating liquid. During the priming phase the side channel stage works like a positive displacement pump.

The displacement effect is created by a rotating liquid ring which enters and exits the side channel in a piston fashion by each rotation. This is generated by an interrupter in the side channel which separates suction and pressure area. The piston effect conveys the gas from suction to discharge side. The priming stage works automatically, no auxiliary vent equipment required.

When pumping LPG, attention must be paid to gas entrainment by vapour bubbles. In practice, these pumps can handle this liquid-gas-mixtures without auxiliary device. Due to the increased pressure in the side channel stage, the gas bubbles turn to liquid gas-phase again.

Suction pipe must be as short as possible and counter pressure on discharge side as low as possible in order to prevent long suction phase.

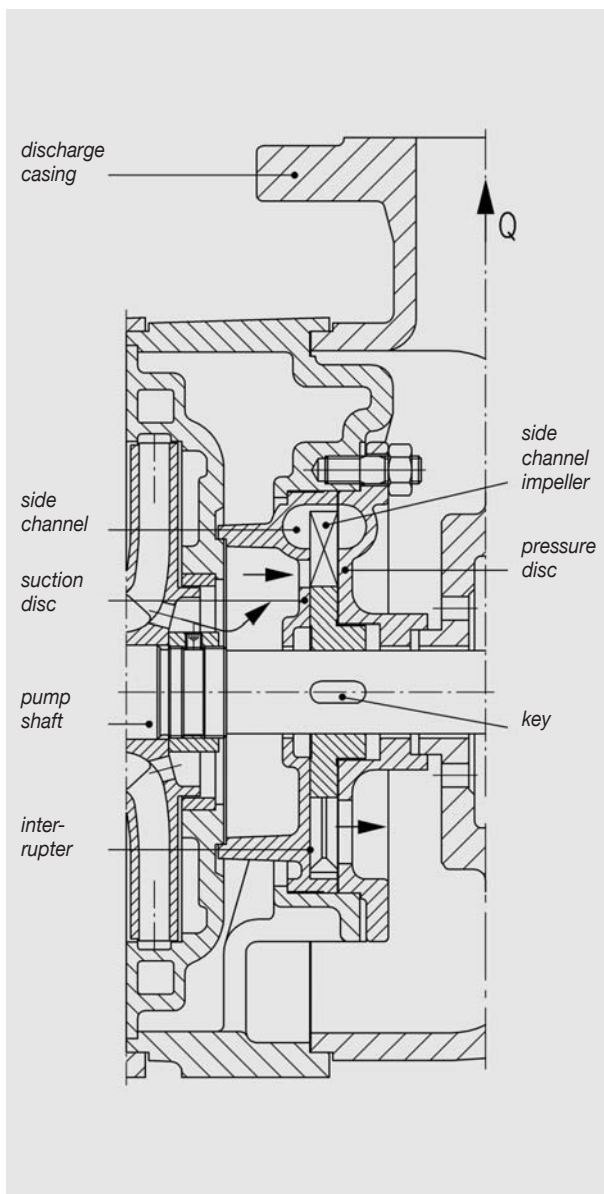

## Materials

Standard materials for HZS/HZSA-pumps are as follows:

Special materials available on request.

Pump part	Material
Suction- and discharge casing	EN-GJS-400-18-LT 1.4408 (G-X5 CrNiMo 18.10) GP 240 GH
Intermediate casing, venting device	EN-GJS-400-18-LT 1.4408 (G-X5 CrNiMo 18.10) GP 240 GH
Impellers and diffusers	EN-GJL-250 1.4408 (G-X5 CrNiMo 18.10)
Priming impeller	1.4457 (G-X25 CrNiMo 25.9)
Suction- and pressure disc	EN-GJL-250 1.4408 (G-X5 CrNiMo 18.10)
Pump shaft	1.4021 (X20 Cr 13) 1.4571 (X10 CrNiMoTi 18.10)
Seal casing	EN-GJS-400-18-LT 1.4408 (G-X5 CrNiMo 18.10)

## Priming stage / side channel stage

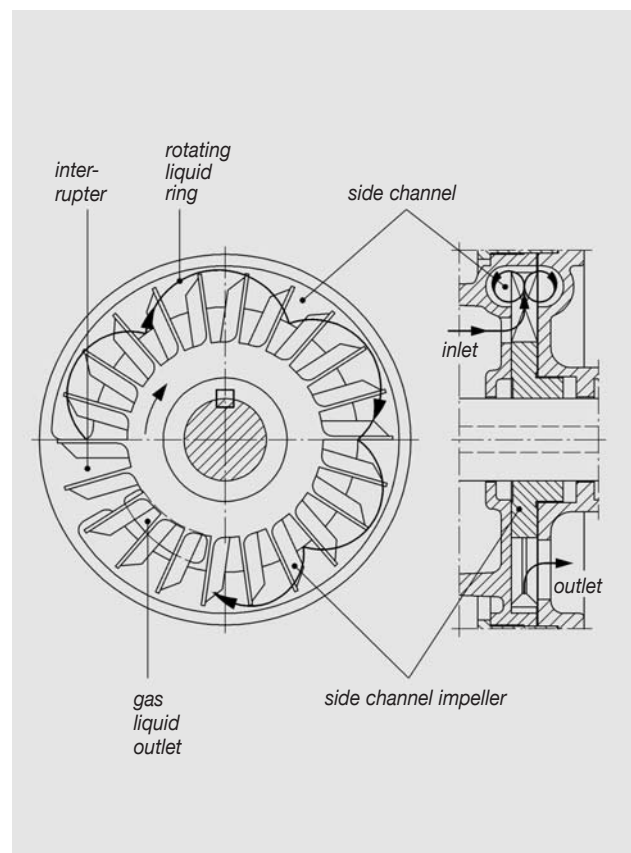

# HZS-Design

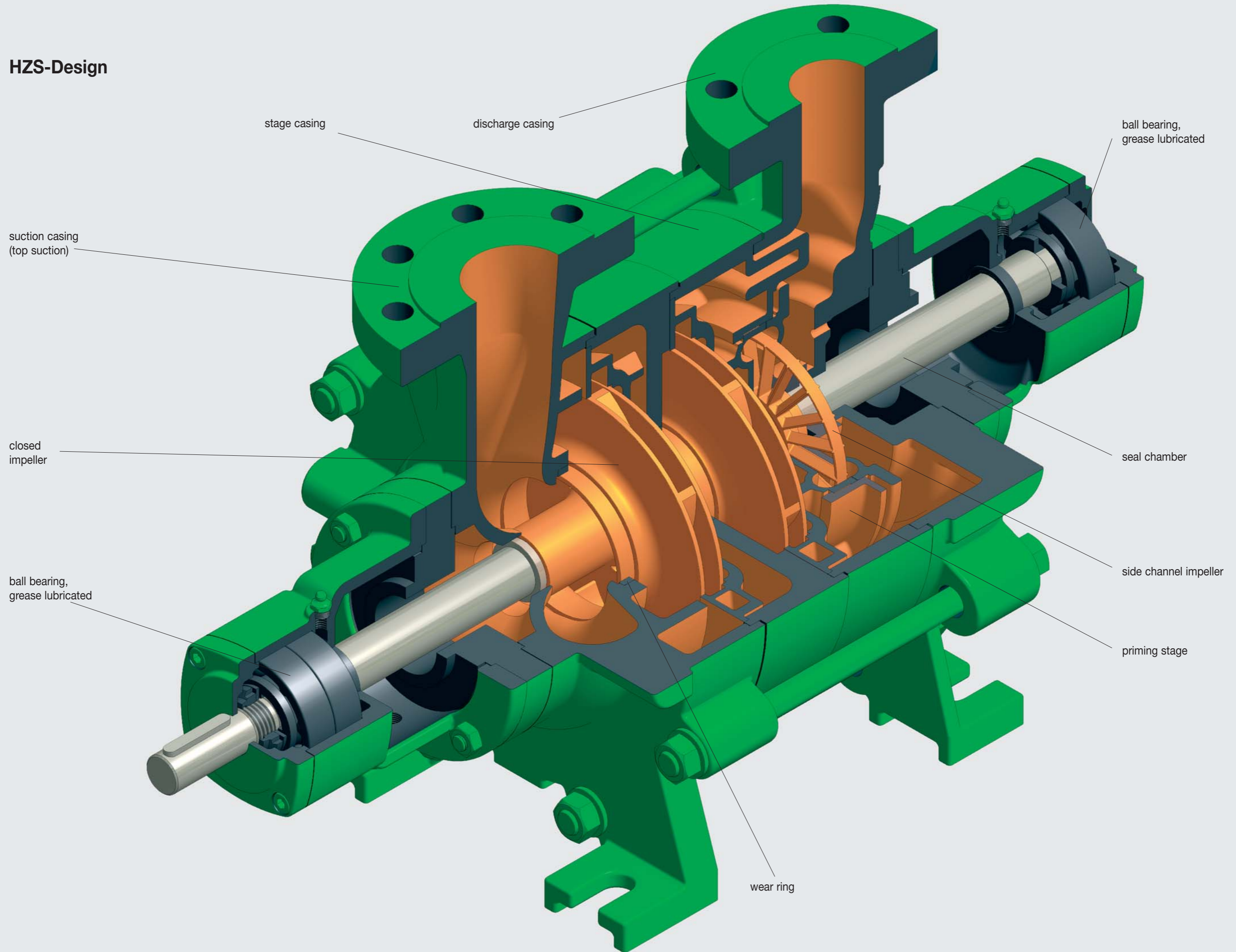

## Shaft sealing systems

The following shaft sealings can be applied, depending on the pumped liquid and customer's specification:

### Examples of available seals

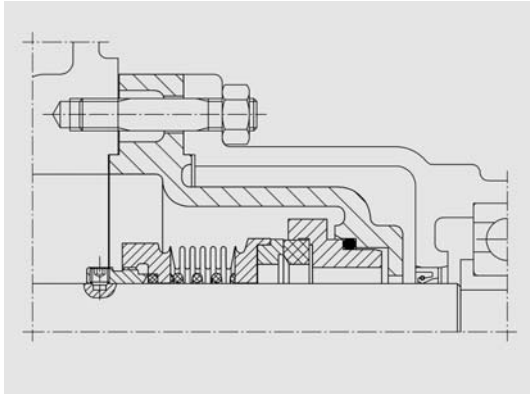

Single bellows mechanical seal,  
system Dickow N6.

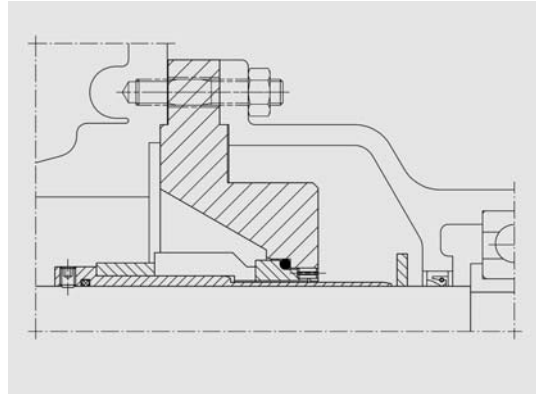

Single mechanical seal,  
acc. to EN 12756.

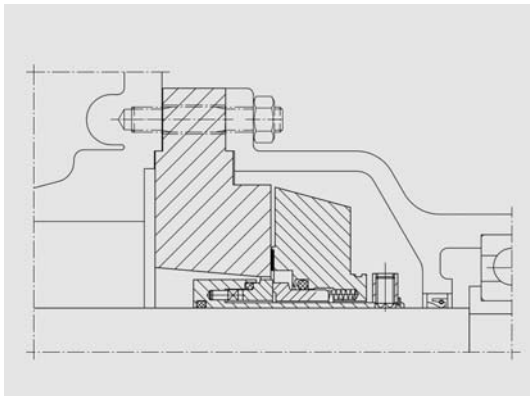

Single mechanical seal, cartridge type,  
for quick and easy maintenance.

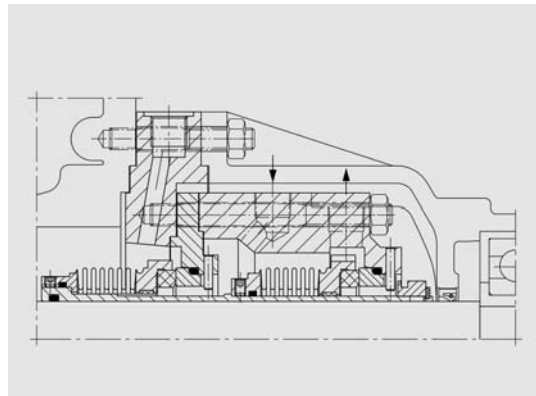

Tandem bellows mechanical seal  
with Plan 52, system Dickow Cart N9,  
for quick and easy maintenance.

Further sealing options are available on request.

## Sectional drawings

### Standard design HZS, selfpriming

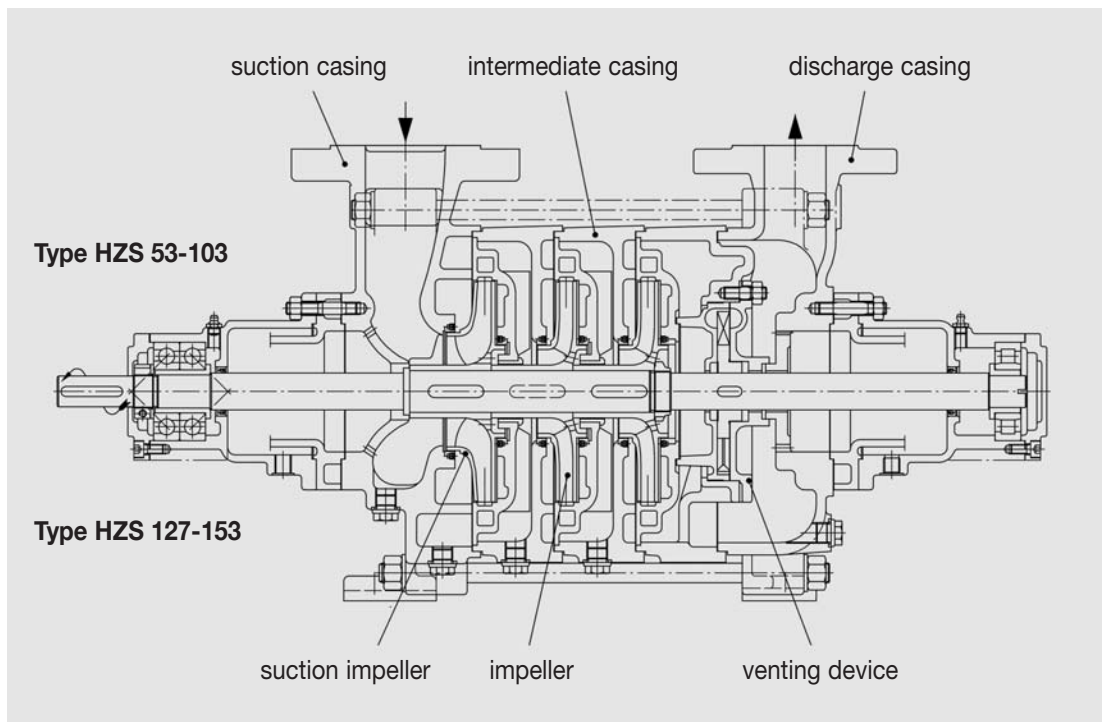

### Standard design HZSA, to handle liquified gas

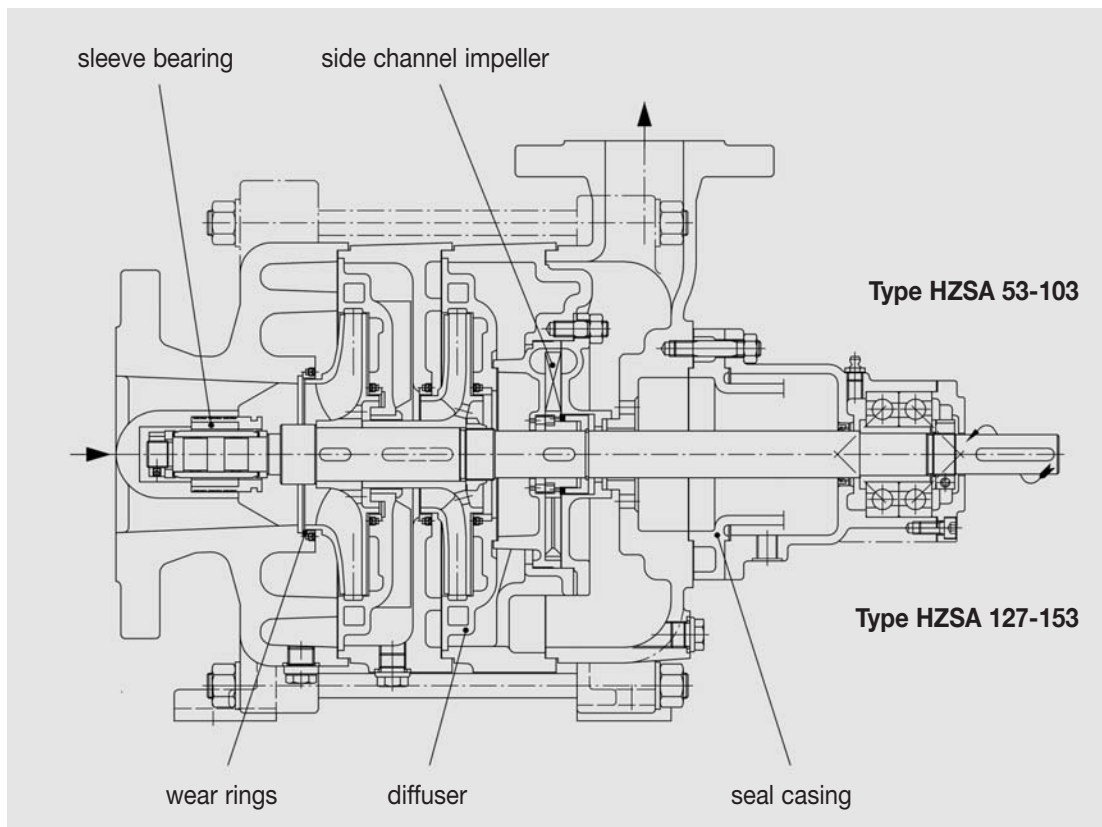

## Performance range

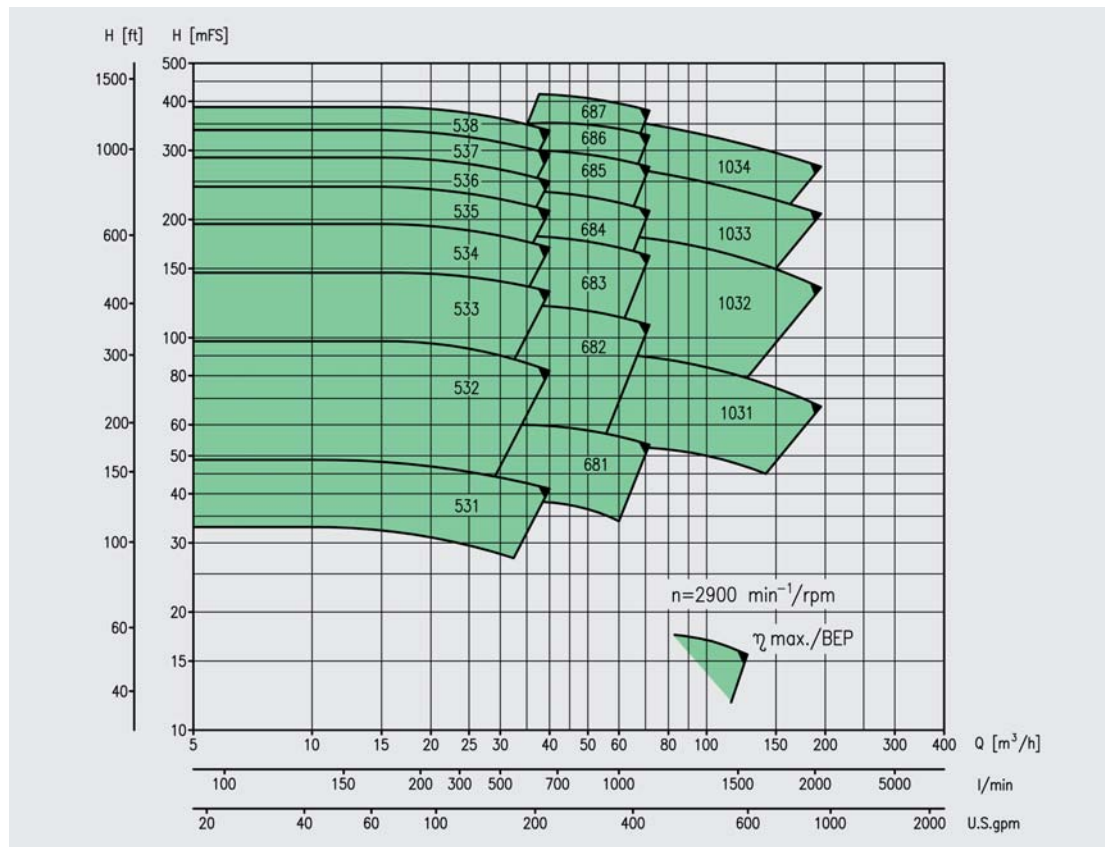
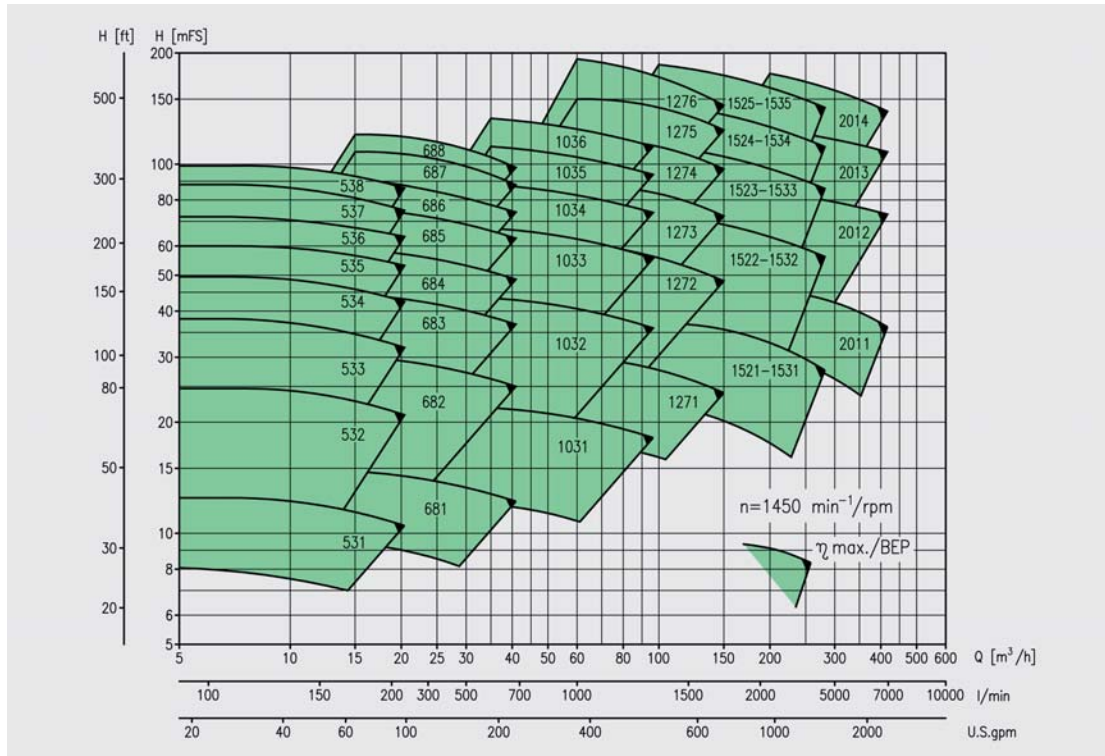

Performance curves for the individual pump sizes, also for 1750 / 3500 rpm, with NPSH-values and power consumption, are available on request.

