

# Quick Guide Inline Filter F-MI4-T

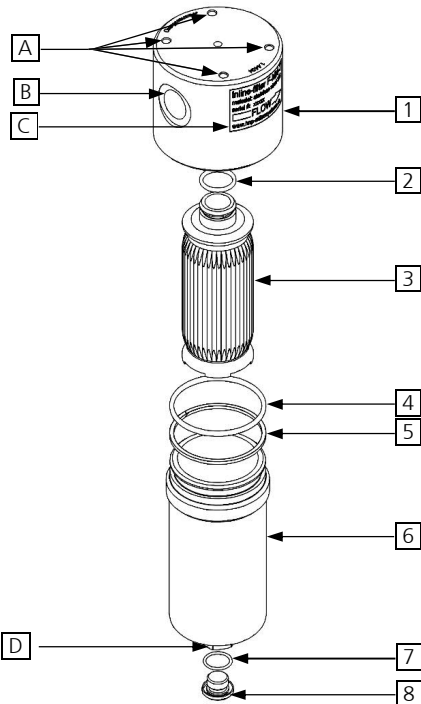

## Technical Data

Dimensions	Value	Pressures	max. Value
Filter area (depends on filter tissue)	approx. 407...450 cm <sup>2</sup> (62...69,75 sq.in.)	Operating pressure (depends on temperature)	200 bar (2900 psi) till 80 °C (176 °F)
Dimensions (Ø x H)	Ø 80 x 173 mm (Ø 3,15...6,81 in.)		180 bar (2610 psi) till 130 °C (266 °F)
Empty volume	200 ml (12,2 cu.in.)		165 bar (2390 psi) till 180 °C (356 °F)
		Differential pressure	155 bar (2245 psi) till 230 °C (446 °F)
			140 bar (2230 psi) till 260 °C (500 °F)
			20 bar (290 psi)

## Items and descriptions

Item no.	Description	Material
1	Filter head	1.4404
2	O-ring Ø 18,3 x 2,4 mm	refer to table "Sealing materials..." below
3	Filter element (mesh sizes)	1.4404 (10, 25, 50, 100 µm)
4	O-ring Ø 54 x 3 mm	refer to table "Sealing materials..." below
5	Support ring for O-ring Ø 54 x 3 mm	PTFE
6	Filter housing	1.4404
7	O-ring Ø 15,1 x 1,6 mm	refer to table "Sealing materials..." below
8	Drain plug G 1/4"	1.4404
A	Mounting holes M6 (4 times)	
B	Fluidic connection G 1/2" (2 times, only inlet port shown)	
C	Label with specifications and flow direction	
D	Hexagon bolt AF 21	

## ⚠ Safety instructions

All of the following tasks must be carried out only by professional and qualified personnel.

The filter must be operated within its specifications. Manipulation, misuse and damaging of the filter are forbidden.

It is only allowed to use original-spare parts.

The internal safety instructions for the used medium must be observed

## Sealing materials and operating temperature ranges

Sealing material	Temperature range
-v FPM	-15...+200 °C (+5...+392 °F)
-e1 EPDM (FDA compliant)	-40...+140 °C (-40...+284 °F)
-f2 FFPM (Kalrez® Spectrum 6375)	-20...+260 °C (-4...+500 °F)
-f3 FFPM (Kalrez® Spectrum 6221, FDA compliant)	-15...+260 °C (+5...+500 °F)

## Installation/Assembly

- The filter should be placed upstream of the component to be protected (i.e. pump)
- Use the mounting holes [A] to mount the filter in the system – the filter housing [6] must point downwards
- ⚠ **Attention!** Fastening the filter only by the fluidic connections [B] is not allowed!
- Ensure a tension free connection of the system tubing to the fluidic connections [B]
- [1] *Instead of the drain plug [8] you can also connect a drain line to the G 1/4"-thread.*

## Commissioning

- Ensure media supply
- Switch system on

## Decommissioning

- Ensure system is shut down, depressurized and eventually cooled down
- Interrupt media supply

## Exchange of filter element

- Required tools / assistive equipment: thread lubricant, Allen wrench size width across flats (AF) 5, screw-wrench AF 21

- Decommissioning (see above)
- Unscrew drain plug [8] carefully with Allen wrench AF 5 out of filter housing [6]. If necessary, hold filter housing [6] at the hexagon bolt AF 21 [D] with screw-wrench
- Capture drain plug [8] and rests of liquid
- ⚠ **Attention!** The drain plug comes with an O-ring [7]!
- Unscrew filter housing [6] at the hexagon bolt AF 21 [D] out of the filter head [1]
- Remove filter element [3] from filter head [1] by pulling and simultaneous slight turning and shaking
- Clean all parts and inspect for damage (especially seals [2], [4], [7] and threads) – replace components if necessary
- If a new support ring [5] is required, place him beneath the O-ring [4], with the concave side facing the filter head [1]
- Eventually attach O-ring [2] on the new or cleaned filter element [3]
- Moisten O-ring [2] with volatile medium such as demineralized water or isopropanol (alternatively with the conveying medium) and carefully insert by hand the filter element [3] by wiggling it into the filter head [1] until it stops

- Insert the drain plug [8] including O-ring [7] into the filter housing [6] and fasten it hand-tight with the Allen wrench AF 5
- Apply thread lubricant on the thread of the filter housing [6]
- Moisten the O-ring [4] with volatile medium such as demineralized water or isopropanol (alternatively with the conveying medium or thread lubricant)
- ⚠ **Attention!** An assembly without lubricant can lead to damage to threads and O-rings!
- Screw the filter housing [6] carefully by hand into the filter head [1]
- [1] *For a faster commissioning, the filter housing [6] can be filled in advance with liquid to about 2/3.*
- Screw the filter housing [6] by the hexagon bolt AF 21 [D] until limit stop, then unfasten 1/4 of a turn
- ⚠ **Attention!** The thread of the filter housing [6] must no longer be visible!
- Perform a pressure test and make a visual inspection of all sealing points
- Commissioning (see above)

## Contact

HNP Mikrosysteme GmbH  
Bleicherufer 25 · D-19053 Schwerin

phone +49 385 52190-301  
fax +49 385 52190-333

e-mail info@hnp-mikrosysteme.de  
http://www.hnp-mikrosysteme.de