

# Quick Guide Inline Filter F-MI3

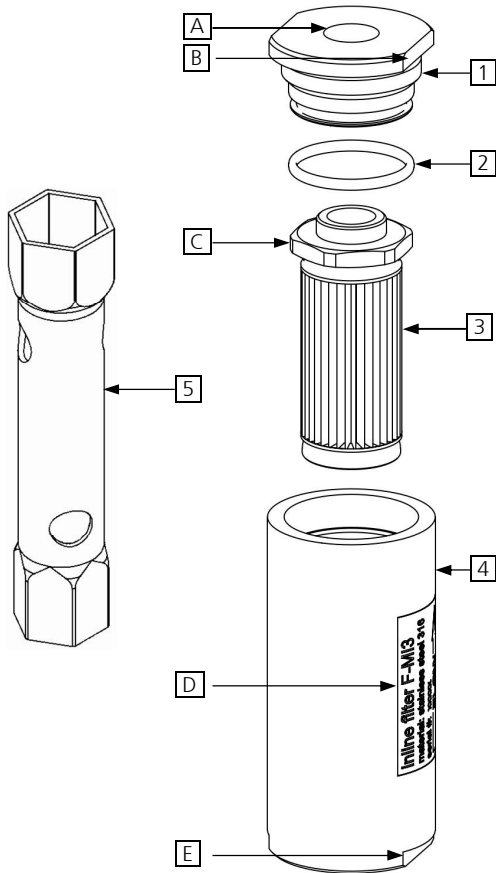

## Technical Data

Dimensions	Value	Pressures	max. Value
Filter area (depends on filter tissue)	approx. 135...150 cm <sup>2</sup> (20,93...23,25 sq.in)	Operating pressure (depends on temperature)	200 bar (2900 psi) till 130 °C (266 °F) 185 bar (2680 psi) till 180 °C (356 °F) 170 bar (2460 psi) till 230 °C (446 °F) 160 bar (2000 psi) till 275 °C (527 °F)
Dimensions (Ø x H)	Ø 48 x 105 mm (Ø 1,89 x 4,13 in.)	Differential pressure	10 bar
Empty volume	65 ml (3,97 cu.in.)		

## Items and descriptions

Item no.	Description	Material
1	Filter cover	1.4404
2	O-ring Ø 31,42 x 2,62 mm	refer to table "Sealing materials..." below
3	Filter element (mesh sizes)	1.4404 (3, 10, 25, 40, 100 µm)
4	Filter housing	1.4404
5	Deep socket wrench AF 32 (special tool, optional available, item No. 92 00 29 09)	
A	Fluidic connection 3/8" NPT (2 times, only outlet port shown)	
B, E	Spanner flat AF 41	
C	Hexagon AF 32	
D	Label with specifications and flow direction	

## Sealing materials and Operating temperature ranges

Sealing material	Temperature range
-v FPM	-15...+200 °C (+5...+392 °F)
-e1 EPDM (FDA compliant)	-50...+140 °C (-58...+284 °F)
-f2 FFPM (Kalrez® Spectrum 6375)	-20...+275 °C (-4...+527 °F)
-f3 FFPM (Kalrez® Spectrum 6221, FDA compliant)	-15...+260 °C (+5...+500 °F)
-f4 FFPM (Perlast® ICE G90LT)	-46...+240 °C (-51...+464 °F)

## ⚠ Safety instructions

All of the following tasks must be carried out only by professional and qualified personnel.

The filter must be operated within its specifications. Manipulation, misuse and damaging of the filter are forbidden.

It is only allowed to use original spare parts. The internal safety instructions for the used medium must be observed.

## Installation/Assembly

- The filter should be placed upstream of the component to be protected (i.e. pump)
- Fasten the filter in the system using a Ø 48 mm pipe clamp (not included in the scope of delivery) - the outlet port **A** should point upwards
  - ⓘ The filter may only be fastened via fluidic connections **A** as long as pipes are connected which are themselves fastened directly in front of or behind the filter in the system.
- Ensure a tension free connection of the system tubing to the fluidic connections **A**
  - ⚠ **Attention!** Basically, for fluidic connectors with NPT-threads use an appropriate thread sealant (i.e. PTFE-tape)!

## Commissioning

- Ensure media supply
- Switch on the system

## Decommissioning

- Ensure system is shut down, depressurized and eventually cooled down
- Interrupt media supply

## Exchange of filter element

- Required tools / assistive equipment: thread lubricant, open-end wrench width across flats (AF) 41, wrench AF 32 (alternatively deep socket wrench AF 32 **5**), bench vice (alternatively a second wrench AF 41)
- Decommissioning (see above)
- Empty the filter in the system
- Remove the filter from the system
- Clamp the filter cover **1** on the wrench flat AF 41 **B** in the bench vice
- Screw the filter housing **4** from the filter cover **1** using a wrench AF 41 **E**
- Unscrew filter element **3** from filter cover **1** using wrench AF 32

- Clean all parts and inspect for damage (especially O-ring **2** and threads) – replace components if necessary
- Carefully insert the new or cleaned filter element **3** by hand into the filter cover **1**
- ⚠ **Attention!** Do not tighten by hand (deformation possible)!
- Tighten the filter element **3** hand-tight using a wrench or socket wrench **5**
- Lubricate the thread on the filter cover **1** with thread lubricant
- Moisten the O-ring **2** with volatile medium such as demineralized water or isopropanol (alternatively with the pumped medium or thread lubricant)
  - ⚠ **Attention!** An assembly without lubricant can lead to damage to threads and O-rings!
- Carefully put the filter housing **4** over the filter element **3** and screw it onto the filter cover **1**
- Screw the filter housing **4** tight until limit stop using the AF 41 wrench flats **E**
- Install the filter into the system according to the installation/assembly instructions
- Perform a pressure test and make a visually inspect of all sealing points
- Commissioning (see above)

## Contact

HNP Mikrosysteme GmbH  
Bleicherufer 25 · D-19053 Schwerin

phone +49 385 52190-301  
fax +49 385 52190-333

e-mail info@hnp-mikrosysteme.de  
http://www.hnp-mikrosysteme.de