

G10 PRO SERIES

Maximum Flow Rate: 33.4 l/min (8.8 USgpm)
Maximum Pressure: 103 bar (1500 psi) for Metallic Pump Heads
24 bar (350 psi) for Non-metallic Pump Heads

WANNER™ HYDRA-CELL® PRO SEAL-LESS PUMP TECHNOLOGIES

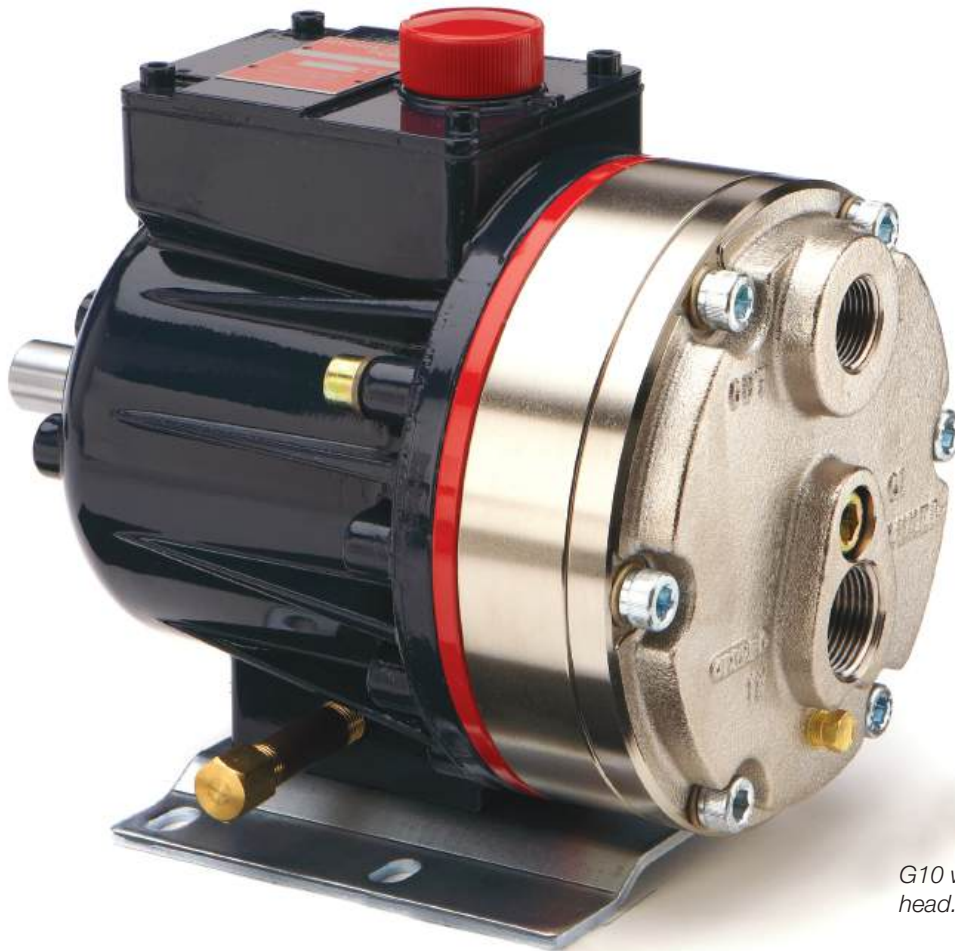

UK
CA CE

G10 with Cast Iron pump head.

A higher standard of pump performance and energy efficiency.

- Integrates **Wanner Hydra-Cell® Pro** seal-less pump technologies for the highest levels of volumetric and energy efficiencies, up to 90% across the full rpm range.
- Reliably handles a wide range of viscosities and shear sensitivities, corrosive liquids, abrasives, slurries and suspended solids.
- No mechanical dynamic seals, packing, or cups to leak, wear or replace – reduces maintenance, costs and downtime.
- Can run dry indefinitely without damage to the pump.
- Seal-less design API 674 pumps that also exceed API 675 standards for accuracy, linearity and repeatability.
- Pumped media is 100% contained – prevents degradation, contamination and environmental risks.
- Patented ADPC (Advanced Diaphragm Position Control) and hydraulic oil management system protect diaphragms under closed or restricted inlet conditions.
- Reduced ownership costs – acquisition, operation, service, maintenance, and energy use.

G10 Pro Series | Performance

Capacities

Model	Max. Input rpm	Max. Flow Capacities @69 bar (1000 psi)		Max. Inlet Pressure		Max. Discharge Pressure					
		l/min	USgpm	bar	psi	Metallic Heads		Polypropylene Heads		PVDF Heads	
						bar	psi	bar	psi	bar	psi
G10-X	1450	30.6	8.1	17	250	69	1000	17	250	24	350
G10-E	1750	33.4	8.8	17	250	69	1000	17	250	24	350

Model	Max. Input rpm	Max. Flow Capacities @103 bar (1500 psi)		Max. Inlet Pressure		Max. Discharge Pressure Metallic Heads	
		l/min	USgpm	bar	psi	bar	psi
G10-X	790	15.1	4.26	17	250	103	1500
G10-E	790	14.7	3.87	17	250	103	1500

Performance and specification ratings apply to G10 configurations unless specifically noted otherwise.

Metering & Dosing

API 675 Performance Characteristics of Steady State Accuracy $\pm 1\%$, Linearity $\pm 3\%$ and Repeatability $\pm 3\%$ can be achieved at speeds up to 790 rpm and pressures up to 103 bar (metallic pump heads) or speeds up to 1440 rpm and pressures up to 24 bar (non-metallic pump heads) or up to 69 bar (metallic pump heads) for X-cam pumps only.

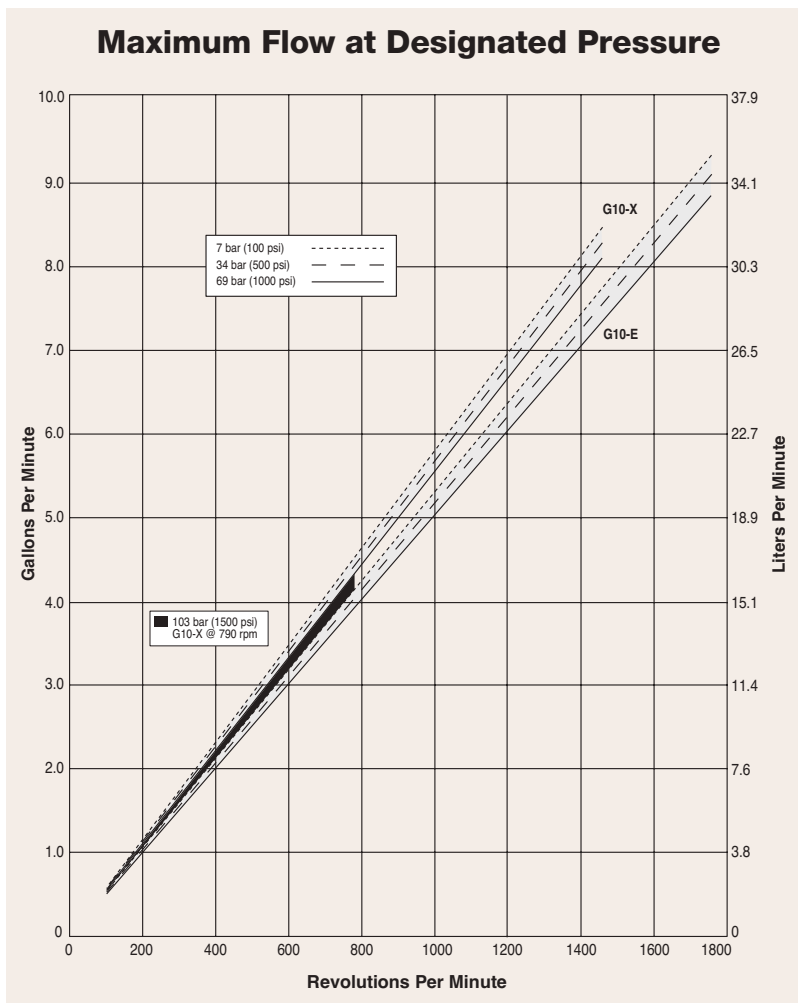

- True positive displacement pumping action achieves overall efficiency of $>90\%$, targeting improvements at lower speeds and higher pressures.

Due to the Wanner Engineering Continuous Improvement Program, specifications and other data are subject to change.

G10 Pro Series | Specifications

Flow Capacities @ 69 bar (1000 psi) 4-pole Motor @ 50 Hz

Model	rpm	l/min	USgpm
G10-X	1450	30.6	8.12
G10-E	1450	27.7	7.39

Flow Capacities @ 69 bar (1000 psi) 6-pole Motor @ 50 Hz

Model	rpm	l/min	USgpm
G10-X	960	20.2	5.37
G10-E	960	18.3	4.89

Delivery @ 103 bar (1500 psi)

Model	litres/rev	gal/rev
G10-X	0.0205	0.0054
G10-E	0.0186	0.0049

Delivery @ 69 bar (1000 psi)

Model	litres/rev	gal/rev
G10-X	0.0211	0.0056
G10-E	0.0191	0.0051

Maximum Discharge Pressure

Metallic Heads:	69 bar (1000 psi) @1450 rpm (G10-X)
	69 bar (1000 psi) @1750 rpm (G10-E)
	103 bar (1500 psi) @790 rpm (G10-X)
Non-metallic Heads:	17 bar (250 psi) Polypropylene
	24 bar (350 psi) PVDF

Maximum Inlet Pressure

17 bar (250 psi)

Maximum Operating Temperature

Metallic Heads:	121°C (250°F) - Consult factory for correct component selection for temperatures from 71°C (160°F) to 121°C (250°F).
Non-metallic Heads:	60°C (140°F)

Maximum Solids Size 500 microns

Calculating Required Power

$$\frac{15 \times \text{rpm}}{63,000} + \frac{\text{gpm} \times \text{psi}}{1,460} = \text{electric motor hp}$$

$$\frac{15 \times \text{rpm}}{84,428} + \frac{\text{l/min} \times \text{bar}}{511} = \text{electric motor kW}$$

Attention!

When using a variable frequency drive (VFD) controller, calculate the hp or kW at minimum and maximum pump speed to ensure the correct hp or kW motor is selected. Note that motor manufacturers typically de-rate the service factor to 1.0 when operating with a VFD.

Calculating Pulley Size

$$\frac{\text{motor pulley OD}}{\text{pump rpm}} = \frac{\text{pump pulley OD}}{\text{motor rpm}}$$

Inlet Port	1 inch BSPT
	1 inch NPT
	150lb ANSI RF Flange
Discharge Port	3/4 inch BSPT
	3/4 inch NPT
	600lb ANSI RF Flange
Shaft Diameter	22.2 mm (7/8 inch)
Shaft Rotation	Reverse (bi-directional)
Bearings	Tapered roller bearings
Oil Capacity	1.05 litres (1.1 US quarts)
Weight	Metallic Heads: 21.8 kg (48 lbs.)
	Non-metallic Heads: 15.9 kg (35 lbs.)

Net Positive Suction Head (NPSHr)

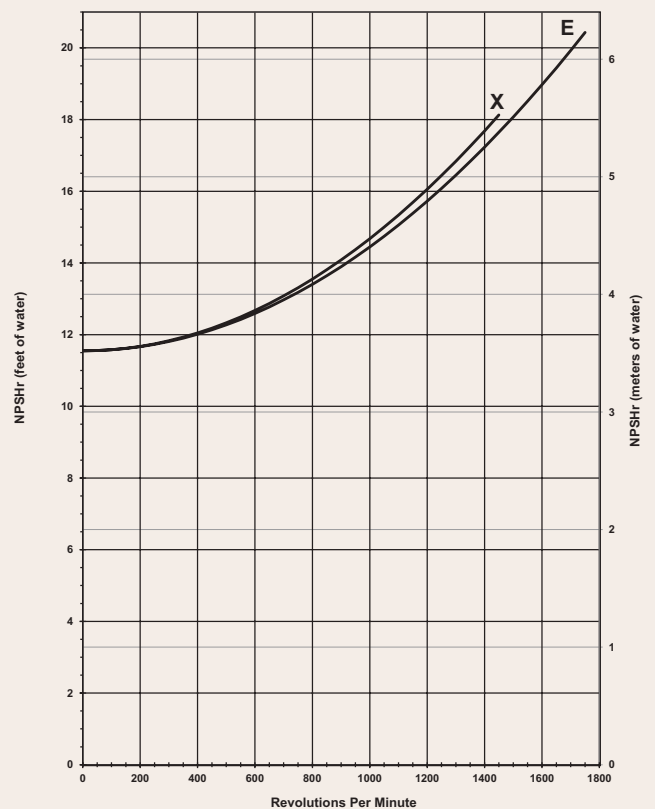

Suction Lift

Each Hydra-Cell pump has different lift capability depending on model size, cam angle, speed, and fluid characteristics. To ensure that your specific lift characteristics are met, refer to the inlet calculations regarding friction, and acceleration head losses in your Hydra-Cell Product Manual. Compare those calculations to the NPSHr curves above.

Due to the Wanner Engineering Continuous Improvement Program, specifications and other data are subject to change.

Baseplate Assembly with Motor Adaptor for IEC 90 Motor Frame

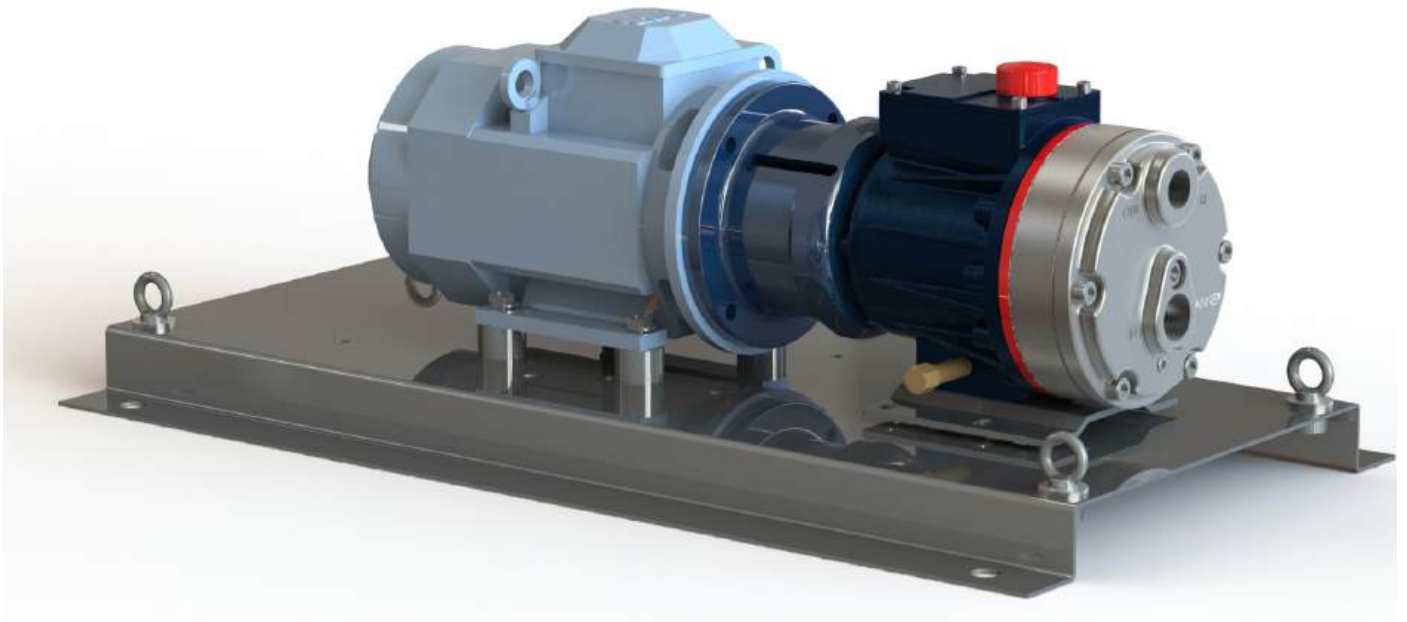

Dimensions in mm

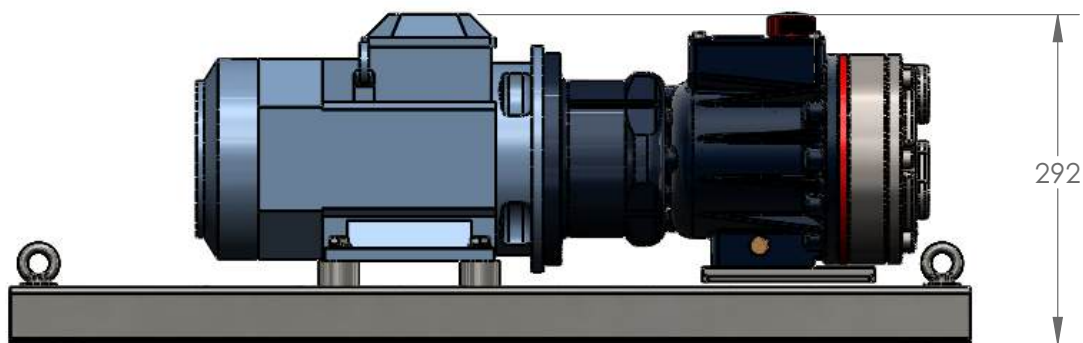
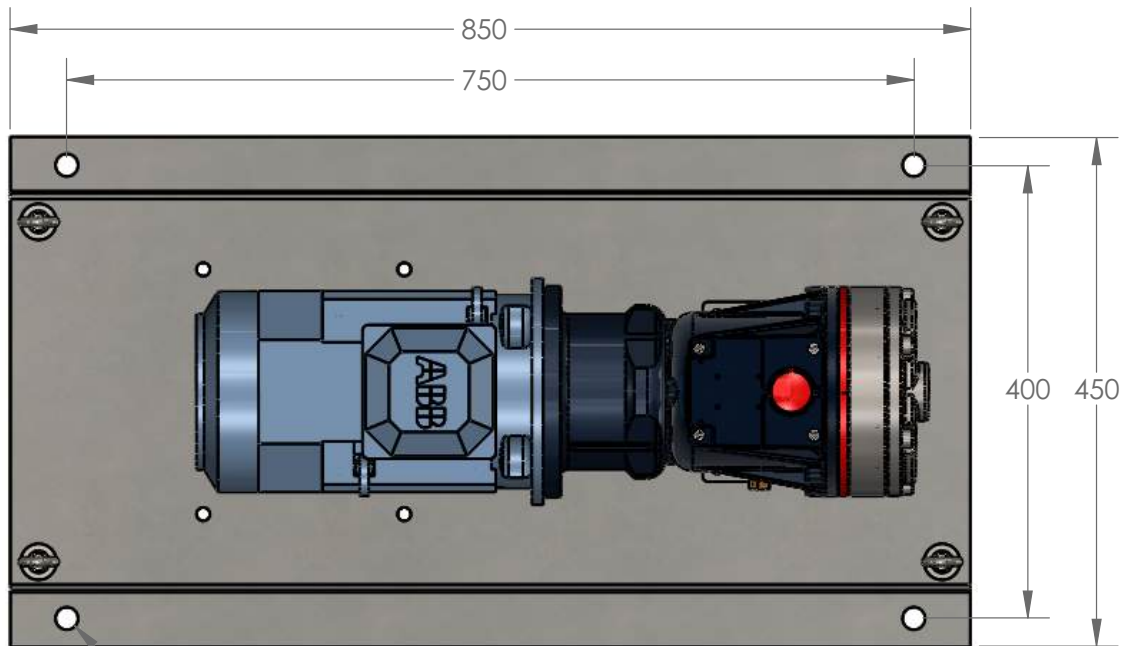

Baseplate Assembly Long-coupled for IEC 90 Motor Frame

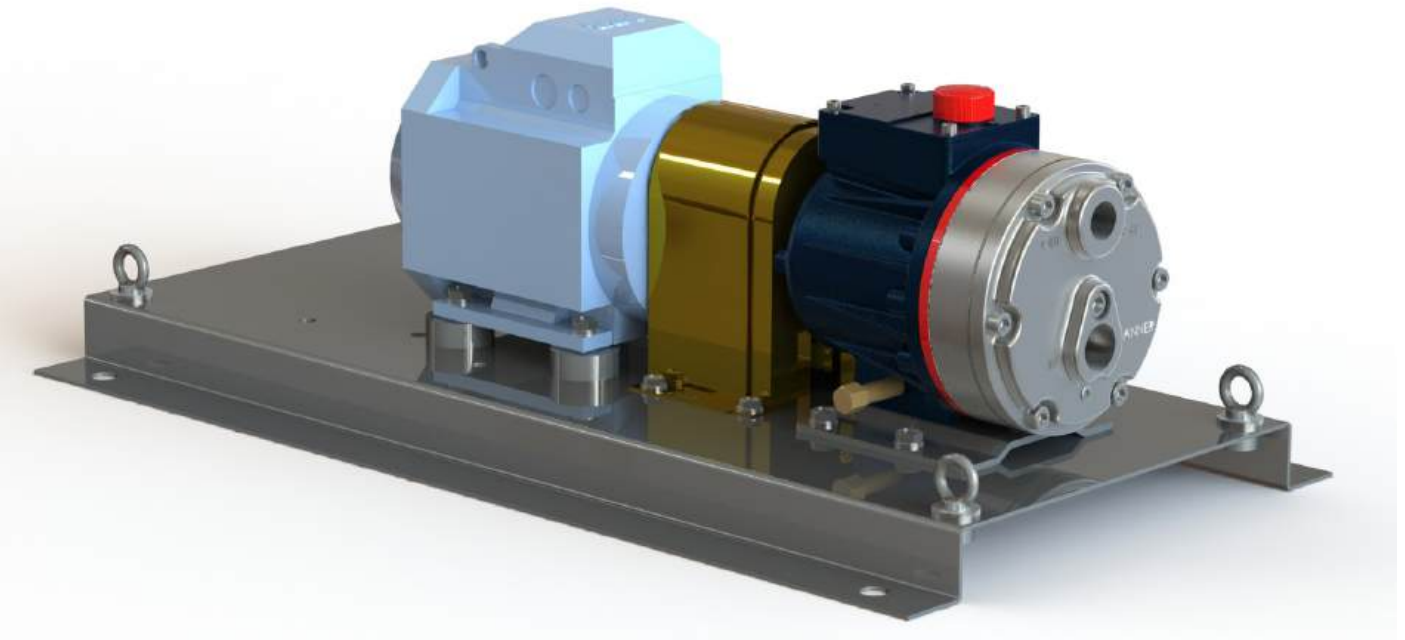

Dimensions in mm

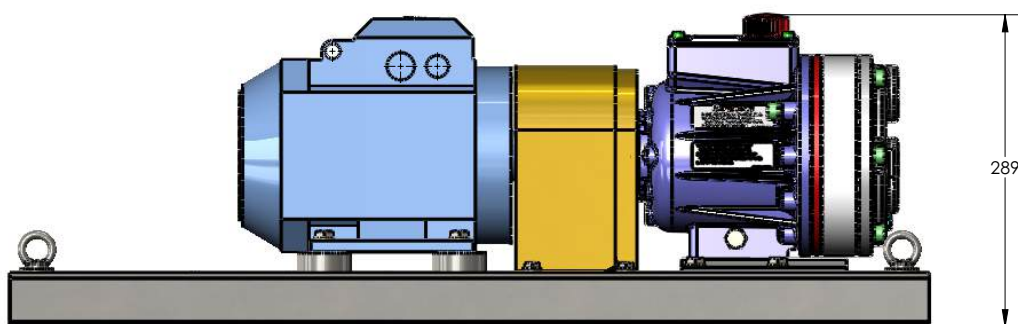
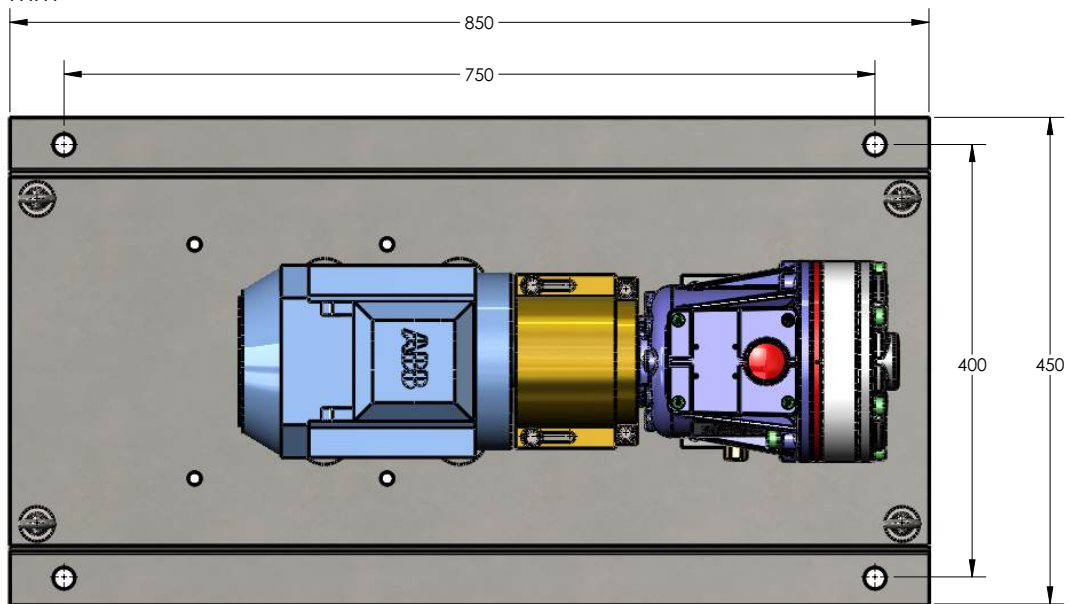

Baseplate Assembly with Motor Adaptor for IEC 100 Motor Frame

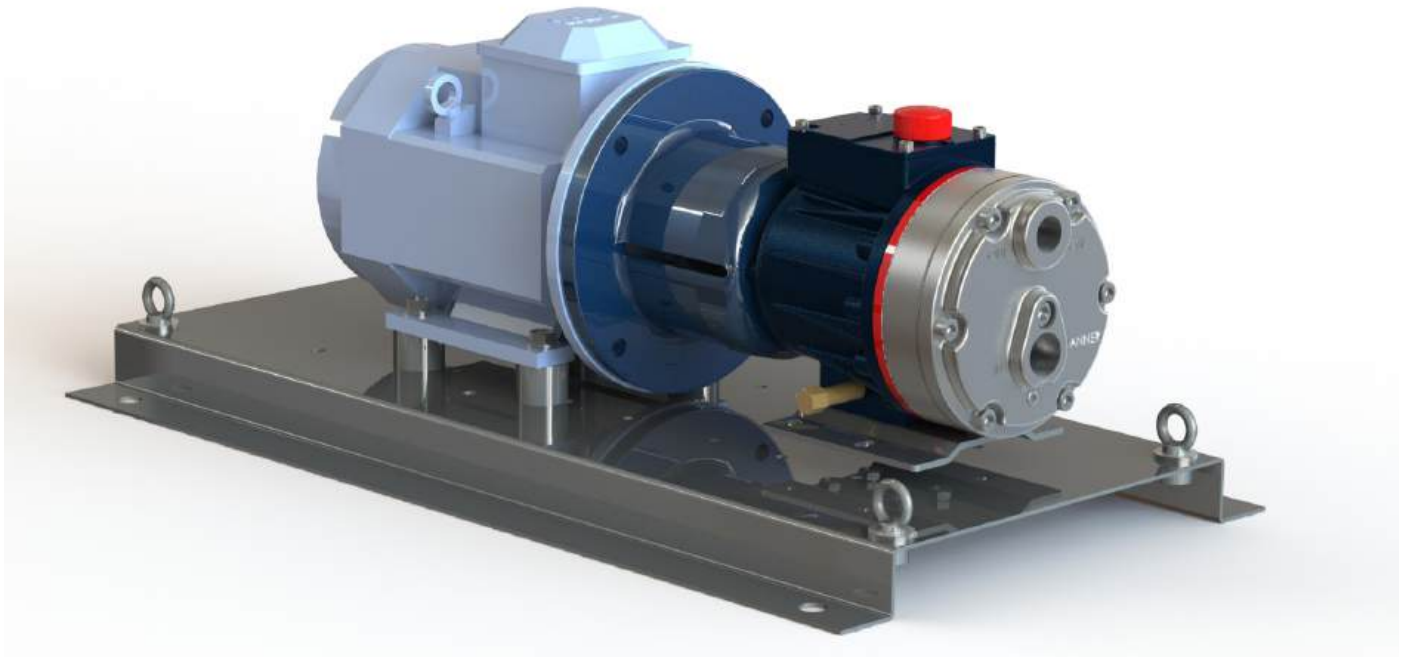

Dimensions in mm

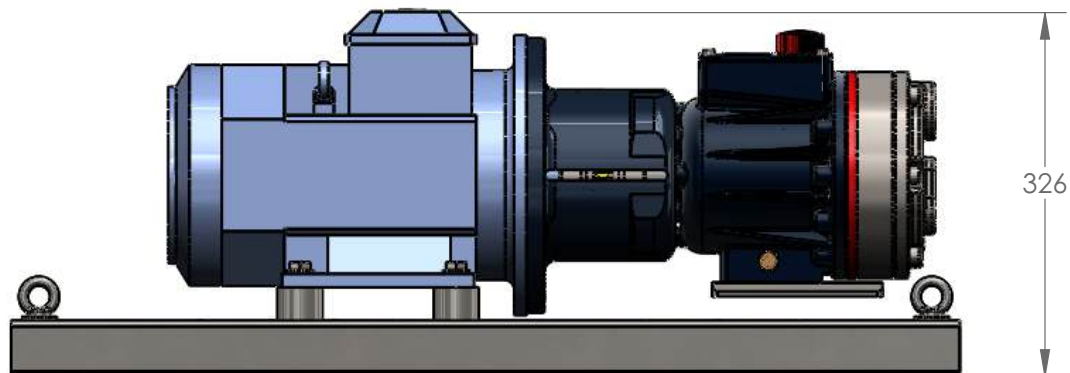
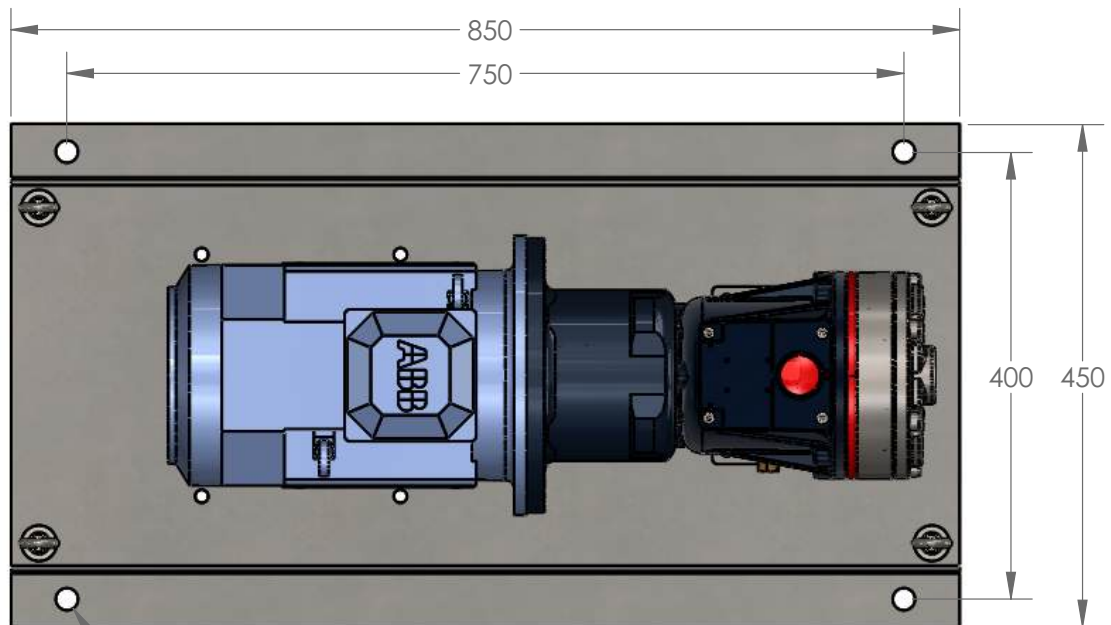

Baseplate Assembly Long-coupled for IEC 100 Motor Frame

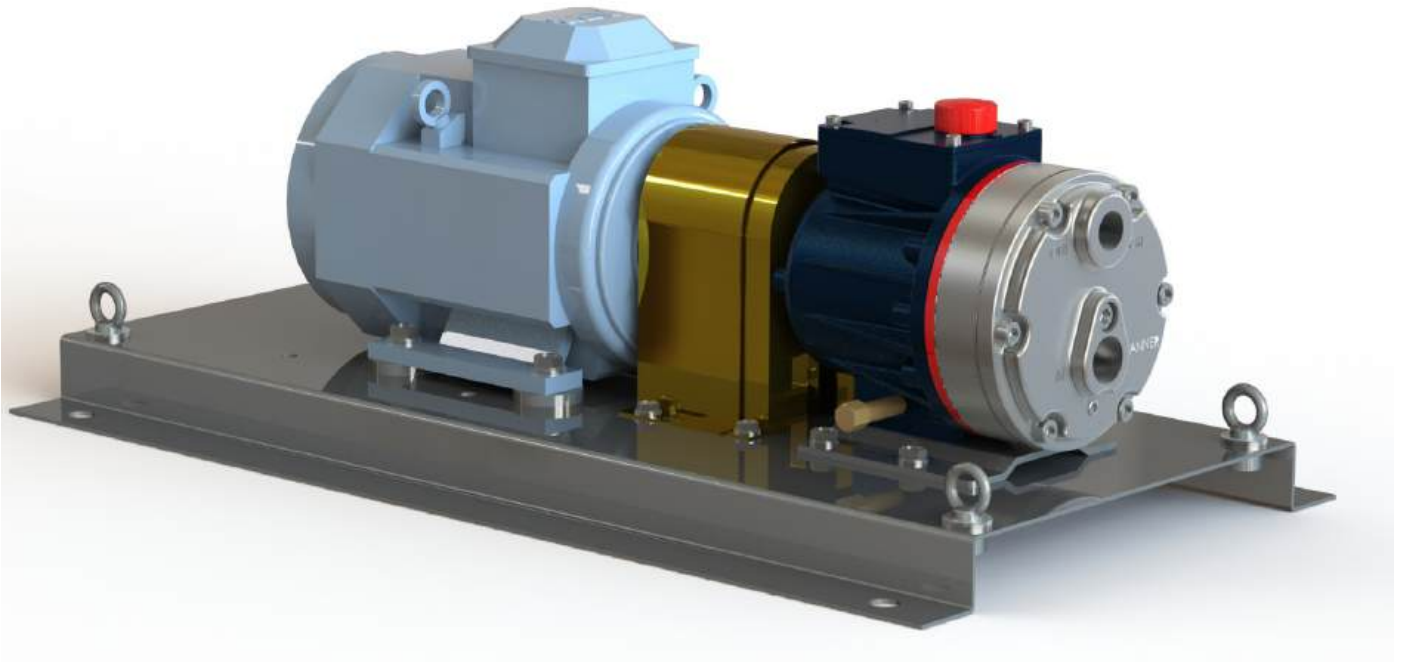

Dimensions in mm

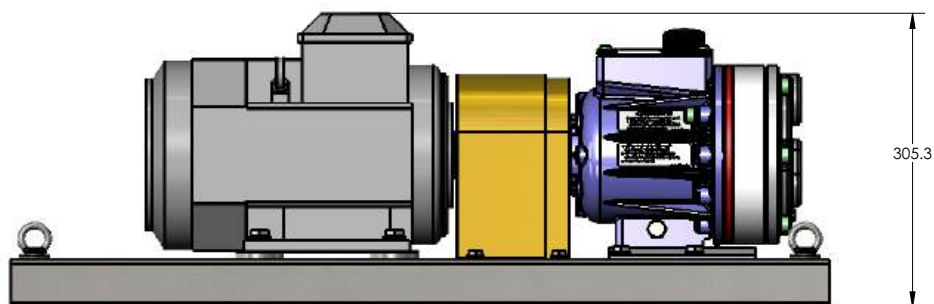
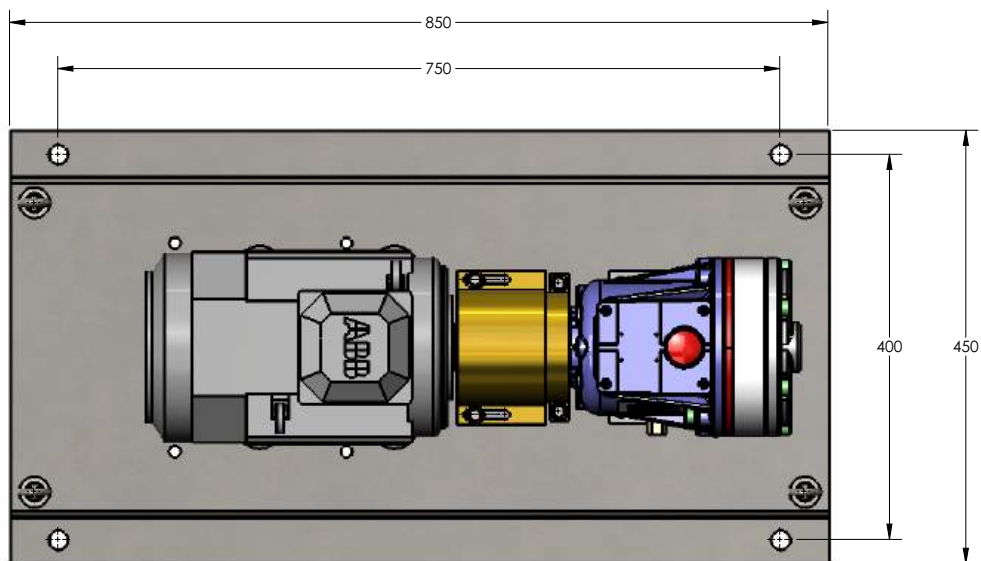

Baseplate Assembly with Motor Adaptor for IEC 132 Motor Frame

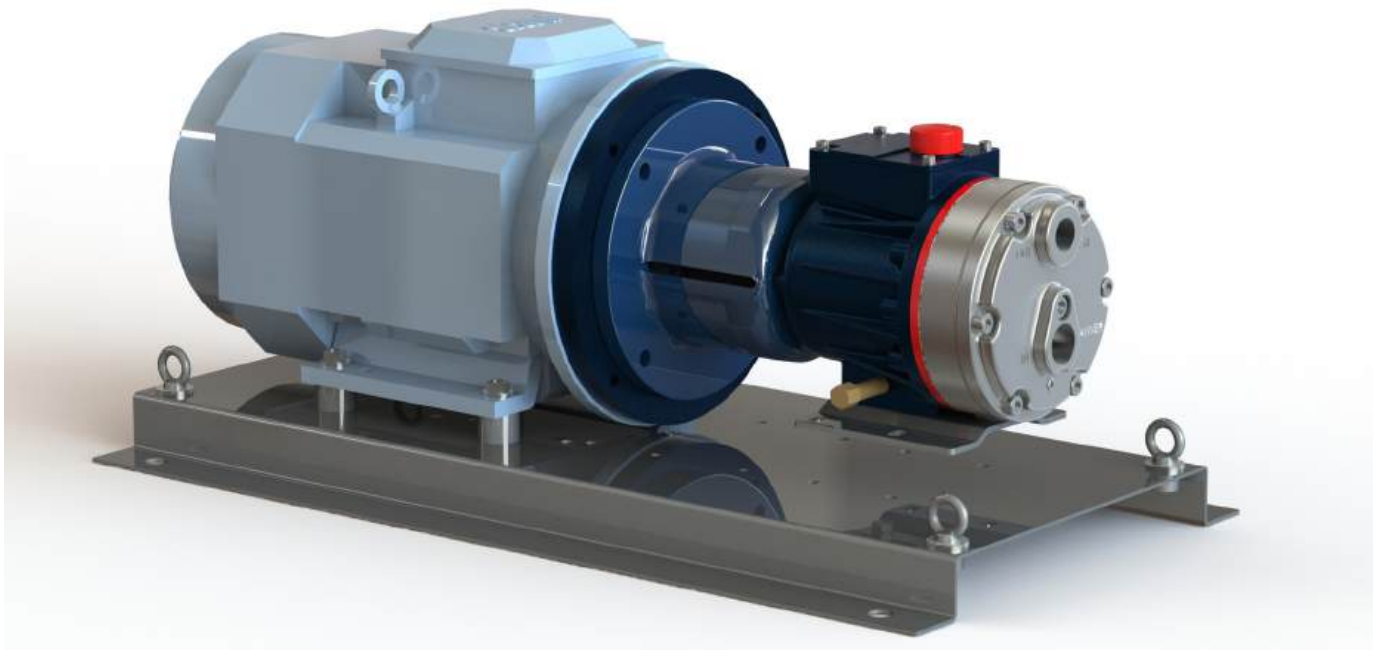

Dimensions in mm

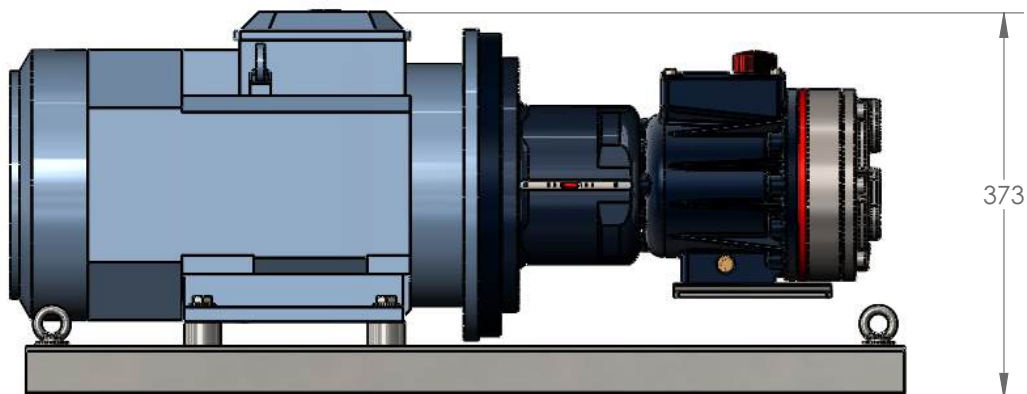
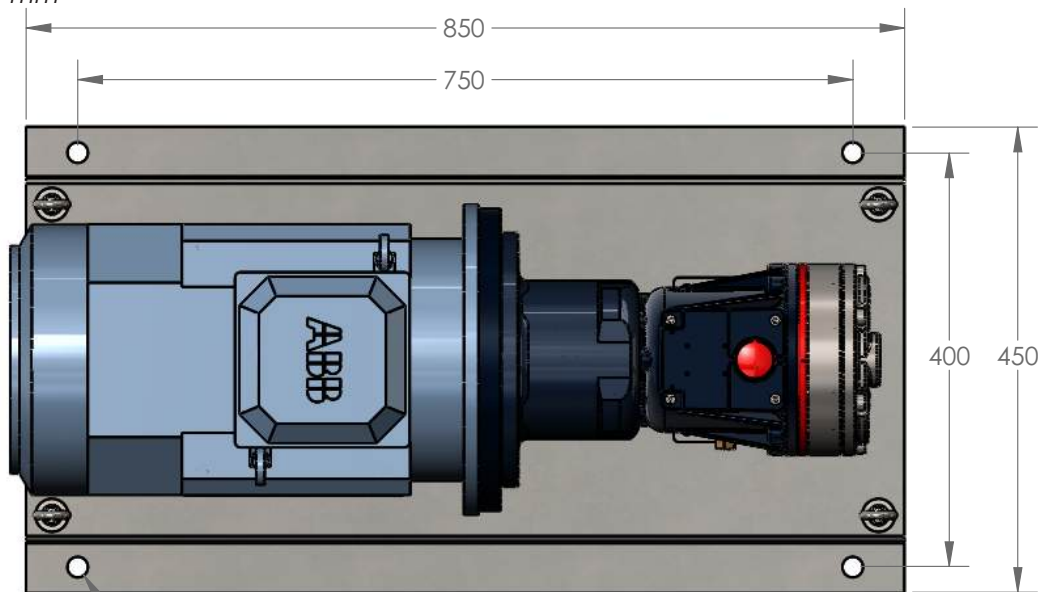

Baseplate Assembly Long-coupled for IEC 132 Motor Frame

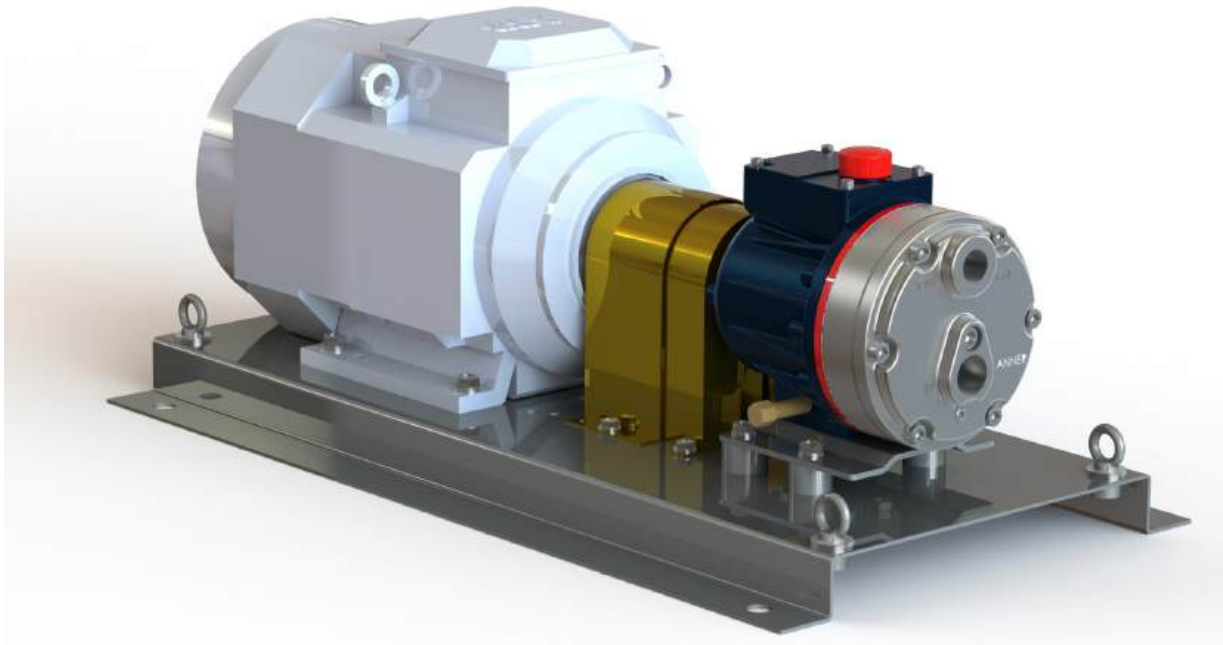

Dimensions in mm

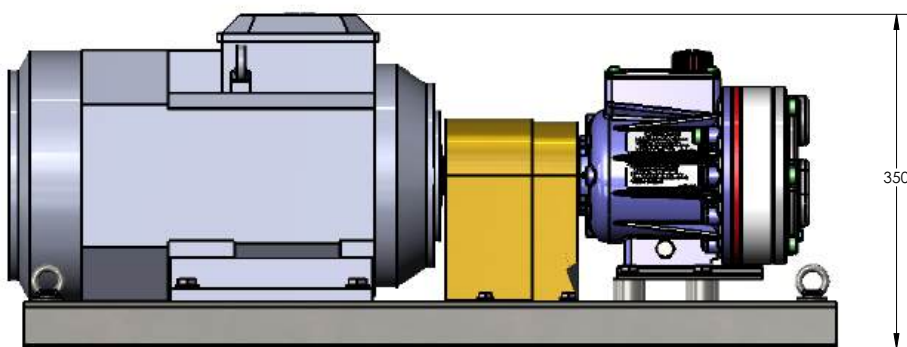
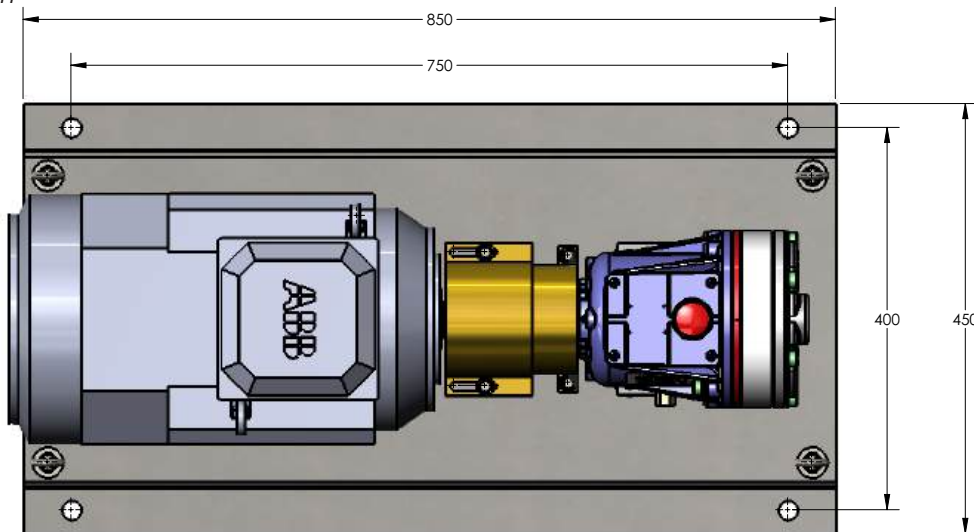

G10 Pro Series | Representative Drawings

G10 Models with Metallic Pump Head mm (Inches)

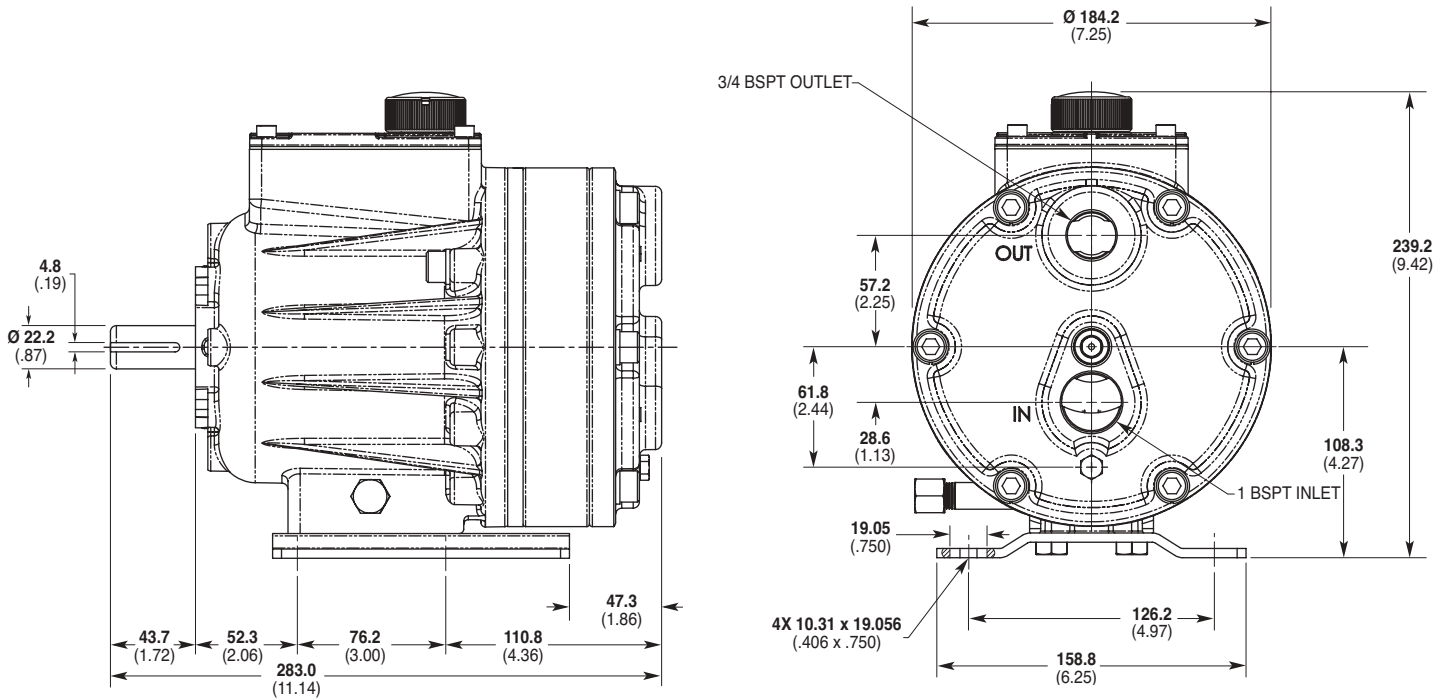

G10 Models with Non-metallic Pump Head mm (Inches)

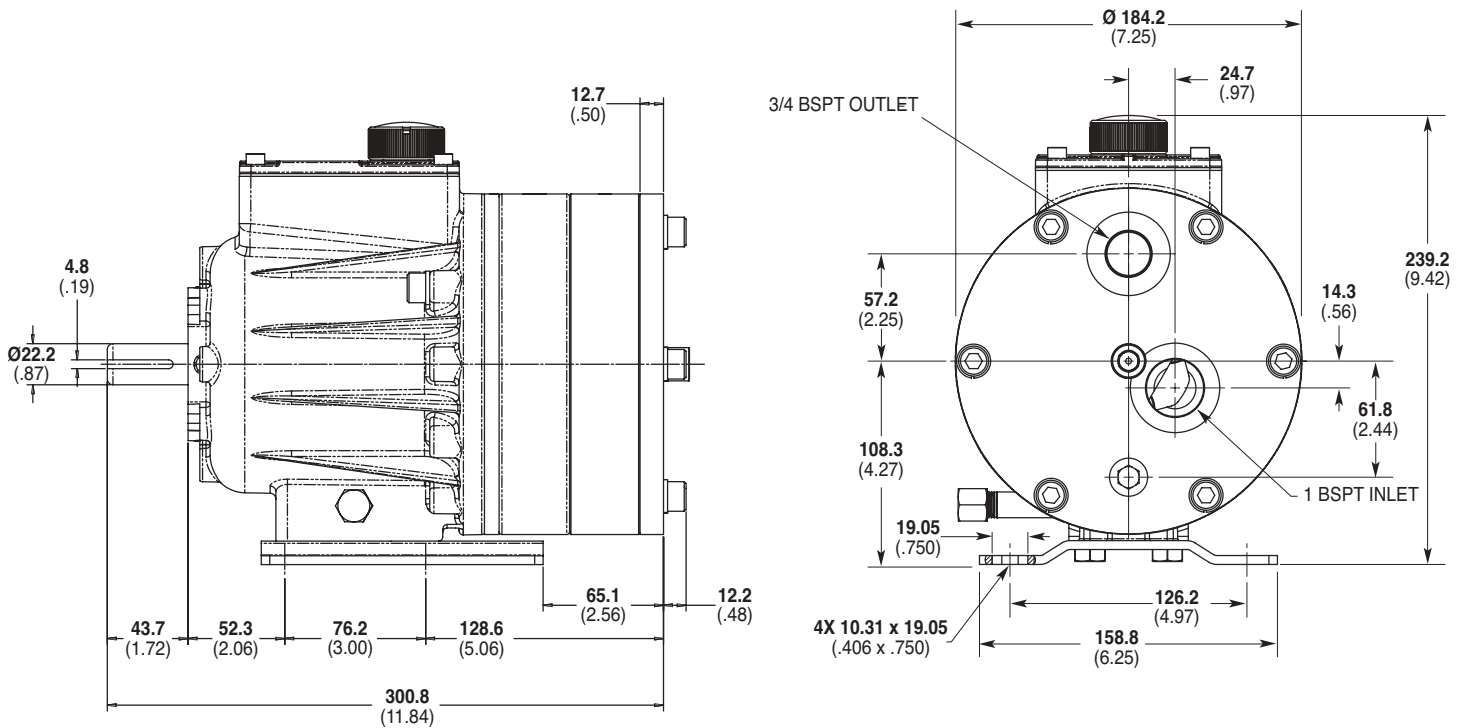

Note: Dimensions are for reference only. Contact factory for certified drawings.

G10 Pro Series | Representative Drawings

G10 Models with ANSI RF Flanges mm (Inches)

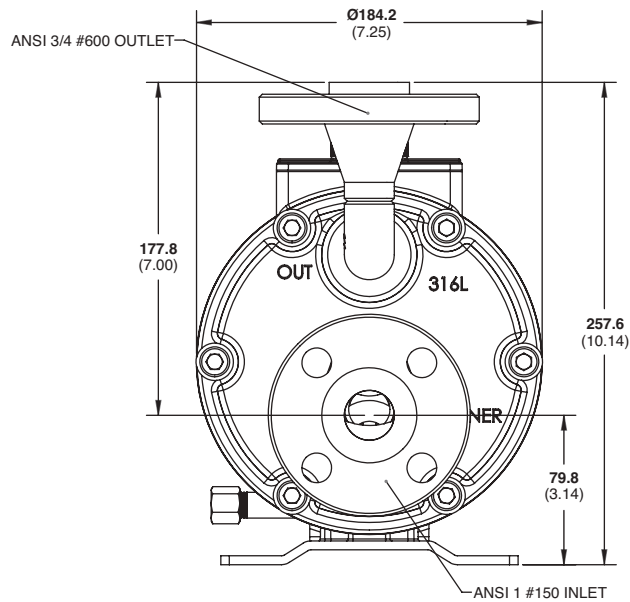
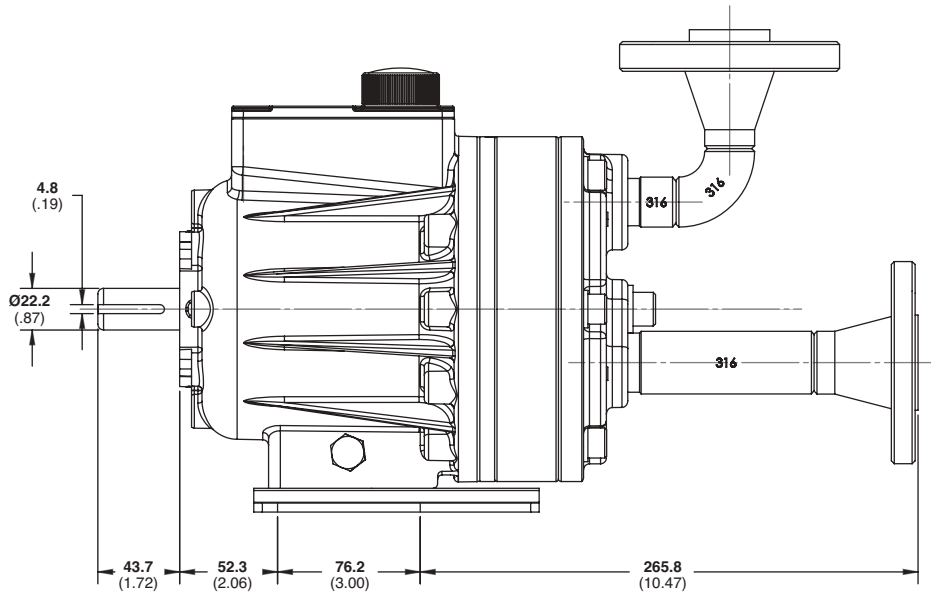

Note: Dimensions are for reference only. Contact factory for certified drawings.

Pump/Motor Adapter mm (Inches)

Part Number: A04-003-1200

Must be ordered separately for G10 models for use with IEC 80 - 90 frame motors, B5 flange.

NEMA adaptor available - consult factory.

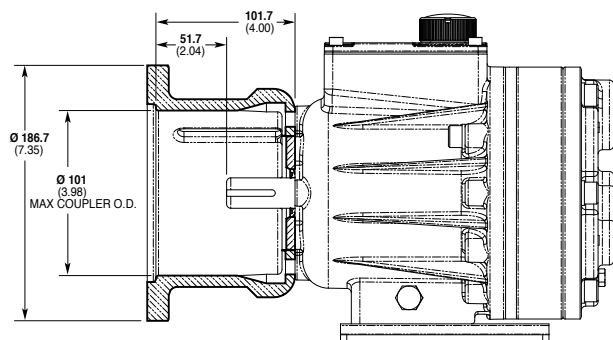

Part Number: A04-004-1200

Must be ordered separately for G10 models for use with IEC 100 - 112 frame motors, B5 flange.

NEMA adaptor available - consult factory.

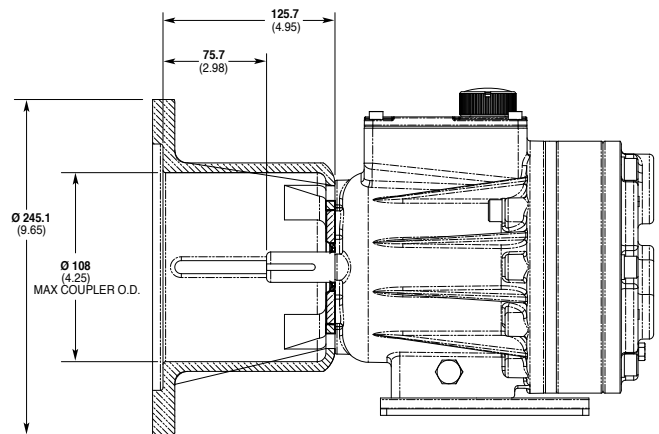

Valve Selection

A seal-less **C62 Pressure Regulating Valve** is recommended for Hydra-Cell G10 pumping systems, especially for high-pressure requirements or when handling dirty fluids.



A **C22 Pressure Regulating Valve** provides a capable, lower-cost alternative to C62 valves for Hydra-Cell G10 pumping systems.



G10 Pro Series | Options

Contact Wanner International for:

- Motors, bases, couplings and other pump accessories
- Hydra-Oil selection and specification information
- Design considerations, installation guidelines, and other technical assistance in pump selection
- Process liquid end built with NACE and 3.1 traceable material certification



G10 with Polypropylene pump head.



D10 with Brass pump head.



G10 with Stainless Steel pump head.



D10 with 316L Stainless Steel pump head and ANSI flanges.

Ordering Information

A complete G10 Series Model Number contains 12 digits including 9 customer-specified design and materials options, for example: G10XKBTHFECA.

1	2	3	4	5	6	7	8	9	10	11	12
G	1	0		P							

Digit	Order Code	Description
1-3	G10	Pump Configuration Shaft-driven (BSPT Ports or ANSI Flanges)* *Pump/motor adaptors ordered separately. See page 12.
4	X E	Hydraulic End Cam Max 30.6 l/min (8.1 USgpm) @ 1450 rpm Max 27.7 l/min (7.3 USgpm) @ 1450 rpm
5	P	Pump Head Version Hydra-Cell Pro <i>See lower right for ATEX Certification Kit Options.</i>
6	B C G M N R - S T	Pump Head Material Brass Cast Iron (Nickel-plated) Duplex Alloy 2205 Stainless Steel (with Hastelloy followers & follower screws) PVDF (with Hastelloy C followers & follower screws) Polypropylene (with Hastelloy C followers & follower screws) 316L Stainless Steel ANSI flange class 316L Stainless Steel standard manifold with custom ANSI or DIN flange options, contact Wanner international with flange specification for part number. 316L Stainless Steel Hastelloy CW12MW
7	A E G J K P T	Diaphragm & O-ring Material Aflas diaphragm / PTFE o-ring EPDM (requires EPDM-compatible oil - Digit 12 oil code C) FKM PTFE (available with E cam only; 1200 rpm max.) FFKM diaphragm / PTFE o-ring Neoprene Buna-N
8	C D H S T	Valve Seat Material Ceramic Tungsten Carbide 17-4 Stainless Steel 316L Stainless Steel Hastelloy C

Digit	Order Code	Description
9	C D F N T	Valve Material Ceramic Tungsten Carbide 17-4 Stainless Steel Nitronic 50 Hastelloy C
10	E T	Valve Springs Elgiloy Hastelloy C
11	C H M P T Y	Valve Spring Retainers Celcon 17-7 Stainless Steel (used with metallic heads only) PVDF Polypropylene Hastelloy C (used with metallic heads only) Nylon
12	A B C E G H	Hydra-Oil 10W30 standard-duty oil 40-wt for continuous-duty (use with 316L SST pump head - standard) 30-wt EPDM-compatible oil Food-contact oil 5W30 cold-temp severe-duty synthetic oil 15W50 high-temp severe-duty synthetic oil

G10 Pump Housing is standard as Cast Aluminum.

Upgrade to Ductile Iron available.

G10 (Plastic Heads Only).

Available with 316 Support Faceplate Kit.



ATEX Certification Kit Options

As a separate line on your order, please add the required ATEX Certification Kit Option.

- ATEX 2014/34/EU Certified, Category 2, Zone 1
- ATEX 2014/34/EU Certified, Category 3, Zone 2





- All options include Certificate, Oil Level Monitor or Sight Glass, Earth Stud & Secondary ATEX Label.
- Extra oil is required to fill the oil bowl during installation of ATEX pumps. This oil is not included and must be ordered separately.
- ATEX is not available with non-metallic pump heads.

Partners in over 70 countries



WANNER™
Global Sales and Technical Support



Americas

-  Minneapolis, Minnesota USA
-  Wichita Falls, Texas USA
-  São Paulo, Brazil
-  Buenos Aires, Argentina

EMEA | Australia

-  Hampshire, United Kingdom
-  Cairo, Egypt
-  Düsseldorf, Germany
-  Lyon, France

Asia | Pacific

-  Kowloon, Hong Kong
-  Shanghai, China
-  Jakarta, Indonesia

India

-  Mumbai, India
-  New Delhi
-  Bangalore
-  Gujarat

Wanner worldwide

GLOBAL SALES & TECHNICAL SUPPORT

WANNER ENGINEERING, INC.

WORLD HEADQUARTERS & MANUFACTURING

Minneapolis, Minnesota USA
t: 612-332-5681
e: sales@wannereng.com
Hydra-Cell.com

REGIONAL OFFICE

Wichita Falls, Texas USA
t: 940-322-7111
e: sales@wannereng.com

LATIN AMERICAN OFFICE

São Paulo, Brazil
t: +55 (11) 99582-1969
e: mmagoni@wannereng.com
Hydra-Cell-Pumps.com.br

WANNER INTERNATIONAL, LTD.

UNITED KINGDOM

Church Crookham, Hampshire UK
t: +44 (0) 1252 816847
e: support@wannerint.com
Hydra-Cell.co.uk

WANNER PUMPS, LTD.

Kowloon, HONG KONG
t: +852 3428 6534
e: sales@wannerpumps.com
WannerPumps.com

Shanghai, CHINA
t: +86-21-6876 3700
e: sales@wannerpumps.com
WannerPumps.com

WANNER INDIA PVT. LTD.

Mumbai, INDIA
t: +91 (22) 22044766
e: support@wannerindia.com
WannerIndia.com



OFFICIAL UK DISTRIBUTOR

Michael Smith Engineers Limited
Web: www.michael-smith-engineers.co.uk
Email: info@michael-smith-engineers.co.uk
Freephone: 0800 316 7891