

G20 PRO SERIES

3.8 l/min (1.0 USgpm)
103 bar (1500 psi) for Metallic Pump Heads
24 bar (350 psi) for Non-metallic Pump Heads

WANNER™ HYDRA-CELL® PRO SEAL-LESS PUMP TECHNOLOGIES



UK CA CE



G20 Close-coupled with Brass pump head

A higher standard of pump performance and energy efficiency.

- Integrates **Wanner Hydra-Cell® Pro** seal-less pump technologies for the highest levels of volumetric and energy efficiencies, up to 90% across the full rpm range.
- Reliably handles a wide range of viscosities and shear sensitivities, corrosive liquids, abrasives, slurries and suspended solids.
- No mechanical dynamic seals, packing, or cups to leak, wear or replace – reduces maintenance, costs and downtime.
- Can run dry indefinitely without damage to the pump.
- Seal-less design API 674 pumps that also exceed API 675 standards for accuracy, linearity and repeatability.
- Pumped media is 100% contained – prevents degradation, contamination and environmental risks.
- Reduced ownership costs – acquisition, operation, service, maintenance, and energy use.
- Valve set design and material options reliably handle a wide range of viscosities and shear sensitivities, plus corrosive liquids, abrasives, slurries and particulates.

WANNER™

G20 Pro Series | Performance

Capacities

Model	Max. Input rpm	Max. Flow Capacities @69 bar (1000 psi)		Max. Inlet Pressure		Max. Discharge Pressure					
		l/min	USgpm	bar	psi	Metallic Heads		Polypropylene Heads		PVDF Heads	
						bar	psi	bar	psi	bar	psi
G20-X	1750	3.82	1.01	17	250	69	1000	17	250	24	350
G22	1750	3.82	1.01	17	250	103	1500	17	250	24	350

Performance and specification ratings apply to G20 and G22 configurations unless specifically noted otherwise.

Metering & Dosing

API 675 Performance Characteristics of Steady State Accuracy $\pm 1\%$, Linearity $\pm 3\%$ and Repeatability $\pm 3\%$ can be achieved at speeds up to 1050 rpm and pressures up to 24 bar (non-metallic pump heads) or up to 103 bar (metallic pump heads) for X-cam pumps only.

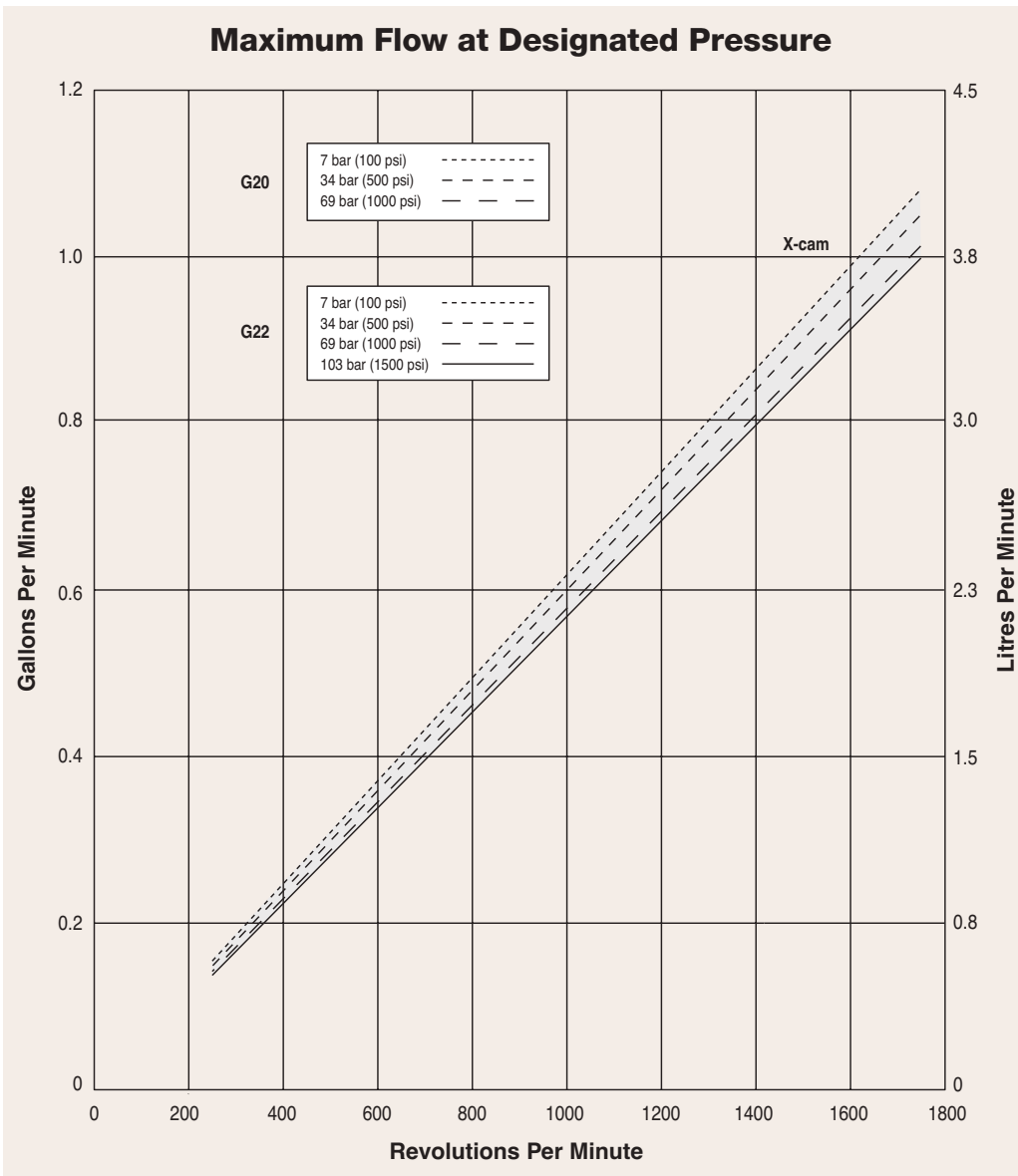

- True positive displacement pumping action achieves overall efficiency of $>90\%$, targeting improvements at lower speeds and higher pressures.

Due to the Wanner Engineering Continuous Improvement Program, specifications and other data are subject to change.

G20 Pro Series | Specifications

Flow Capacities @ 69 bar (1000 psi) 4-pole Motor @ 50 Hz

Model	rpm	l/min	USgpm
G20-X	1450	3.19	0.87

Flow Capacities @ 69 bar (1000 psi) 6-pole Motor @ 50 Hz

Model	rpm	l/min	USgpm
G20-X	960	2.11	0.57

Delivery @ 69 bar (1000 psi)

Model	litres/rev	gal/rev
G20-X	0.0022	0.0006

Maximum Discharge Pressure

Metallic Heads:	G20 to 69 bar (1000 psi)
Non-metallic Heads:	17 bar (250 psi) Polypropylene 24 bar (350 psi) PVDF

Maximum Inlet Pressure

17 bar (250 psi)

Maximum Operating Temperature

Metallic Heads: 121°C (250°F) - Consult factory for correct component selection for temperatures from 71°C (160°F) to 121°C (250°F).

Non-metallic Heads: 60°C (140°F)

Maximum Solids Size

200 microns

Inlet Port

1/2 inch BSPT

1/2 inch NPT

Discharge Port

3/8 inch BSPT

3/8 inch NPT

Shaft Diameter

G20: 19 mm (3/4 inch) hollow shaft
G22: 19 mm (3/4 inch)

Shaft Rotation

Reverse (bi-directional)

Bearings

Precision ball bearings

Oil Capacity

0.12 litres (0.125 US quart)

Weight

Metallic Heads: 5.5 kg (12 lbs.)

Non-metallic Heads: 4.1 kg (9 lbs.)

Calculating Required Power

$$\frac{\text{rpm} + 1000}{7000} + \frac{\text{gpm} \times \text{psi}}{1,460} = \text{electric motor hp}$$

$$\frac{\text{rpm} + 1000}{9383} + \frac{\text{l/min} \times \text{bar}}{511} = \text{electric motor kW}$$

Attention!

When using a variable frequency drive (VFD) controller, calculate the hp or kW at minimum and maximum pump speed to ensure the correct hp or kW motor is selected. Note that motor manufacturers typically de-rate the service factor to 1.0 when operating with a VFD.

Calculating Pulley Size

$$\frac{\text{motor pulley OD}}{\text{pump rpm}} = \frac{\text{pump pulley OD}}{\text{motor rpm}}$$

Due to the Wanner Engineering Continuous Improvement Program, specifications and other data are subject to change.

Net Positive Suction Head (NPSHr)

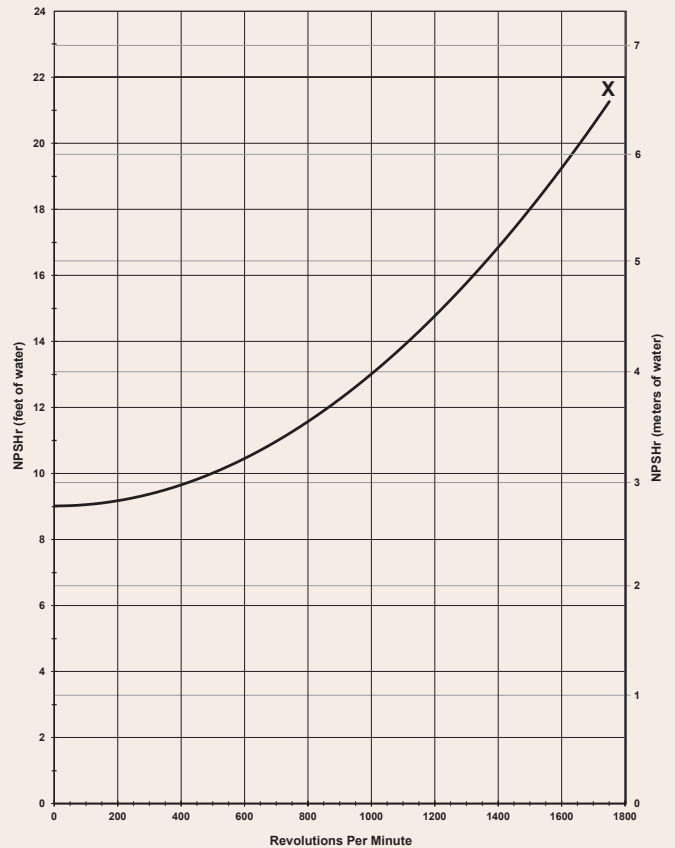

Suction Lift

Each Hydra-Cell pump has different lift capability depending on model size, cam angle, speed, and fluid characteristics. To ensure that your specific lift characteristics are met, refer to the inlet calculations regarding friction, and acceleration head losses in your Hydra-Cell Product Manual. Compare those calculations to the NPSHr curves above.

Baseplate Assembly with Motor Adaptor for IEC 80 Motor Frame

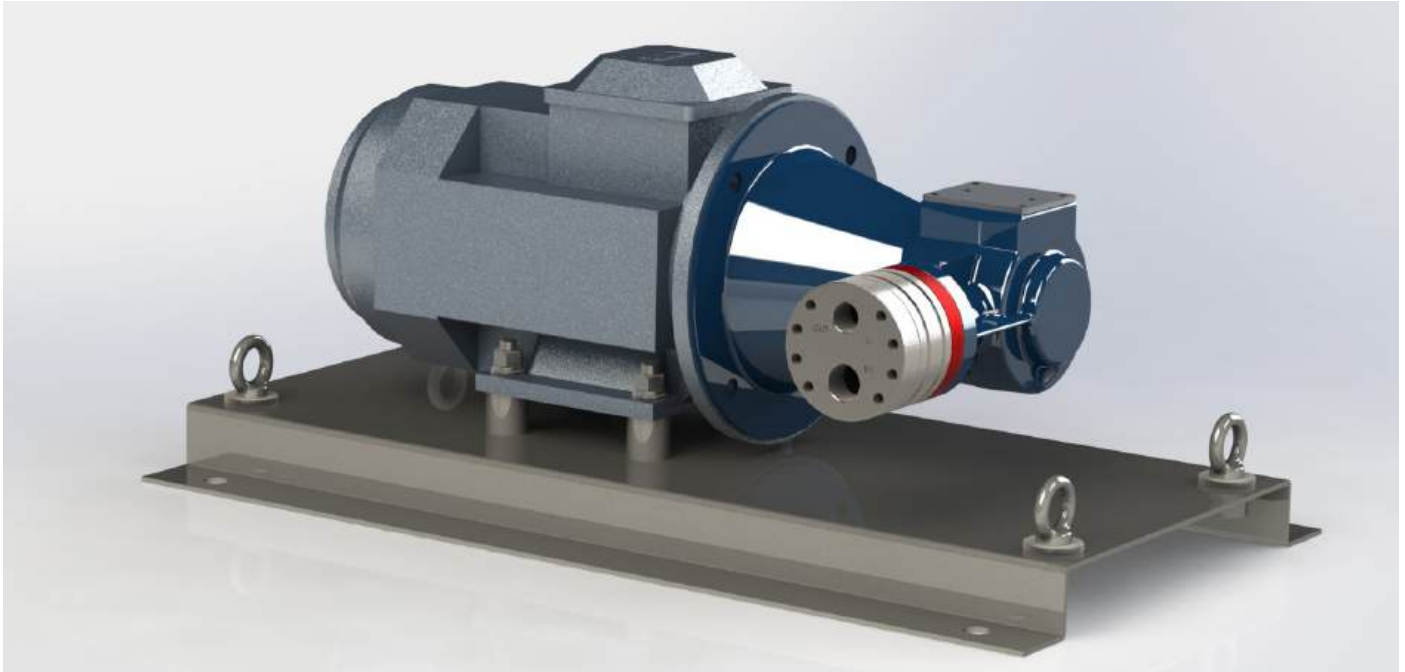

Dimensions in mm

G22 pump shown

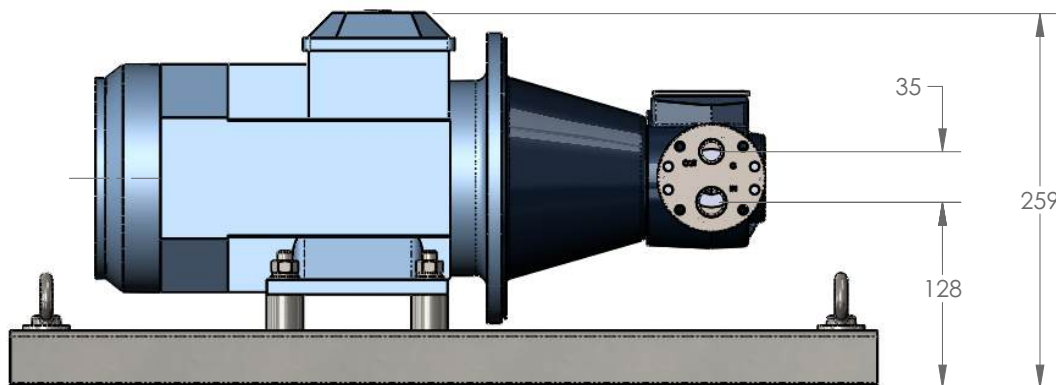
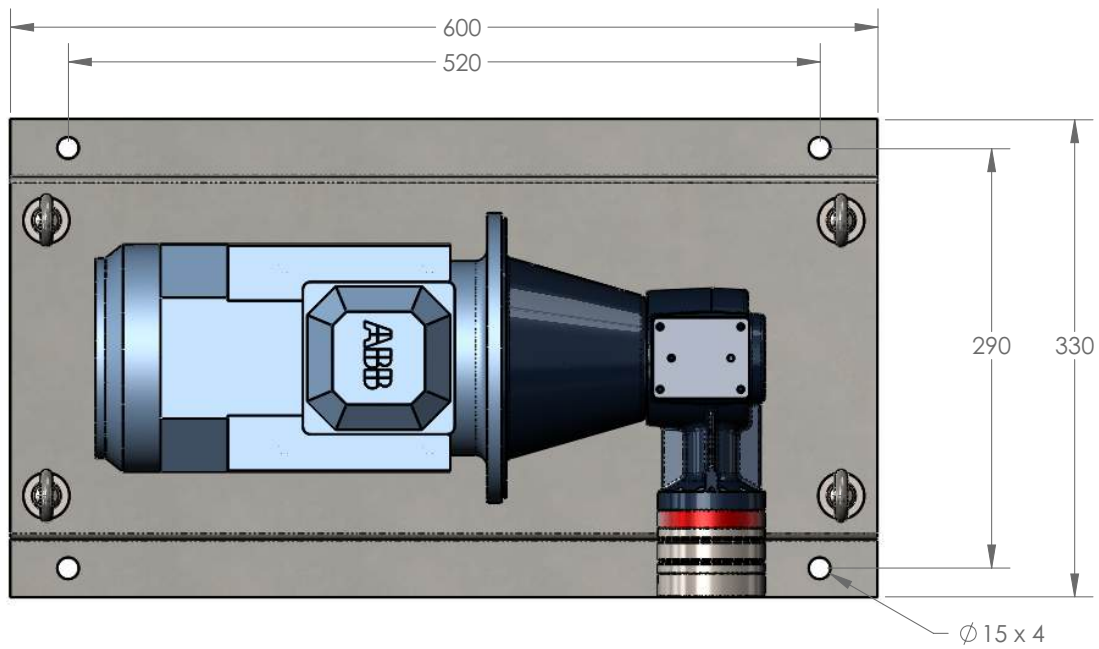

G20 Pro Series | Representative Drawings

G20 Models with Metallic Pump Head mm (Inches)

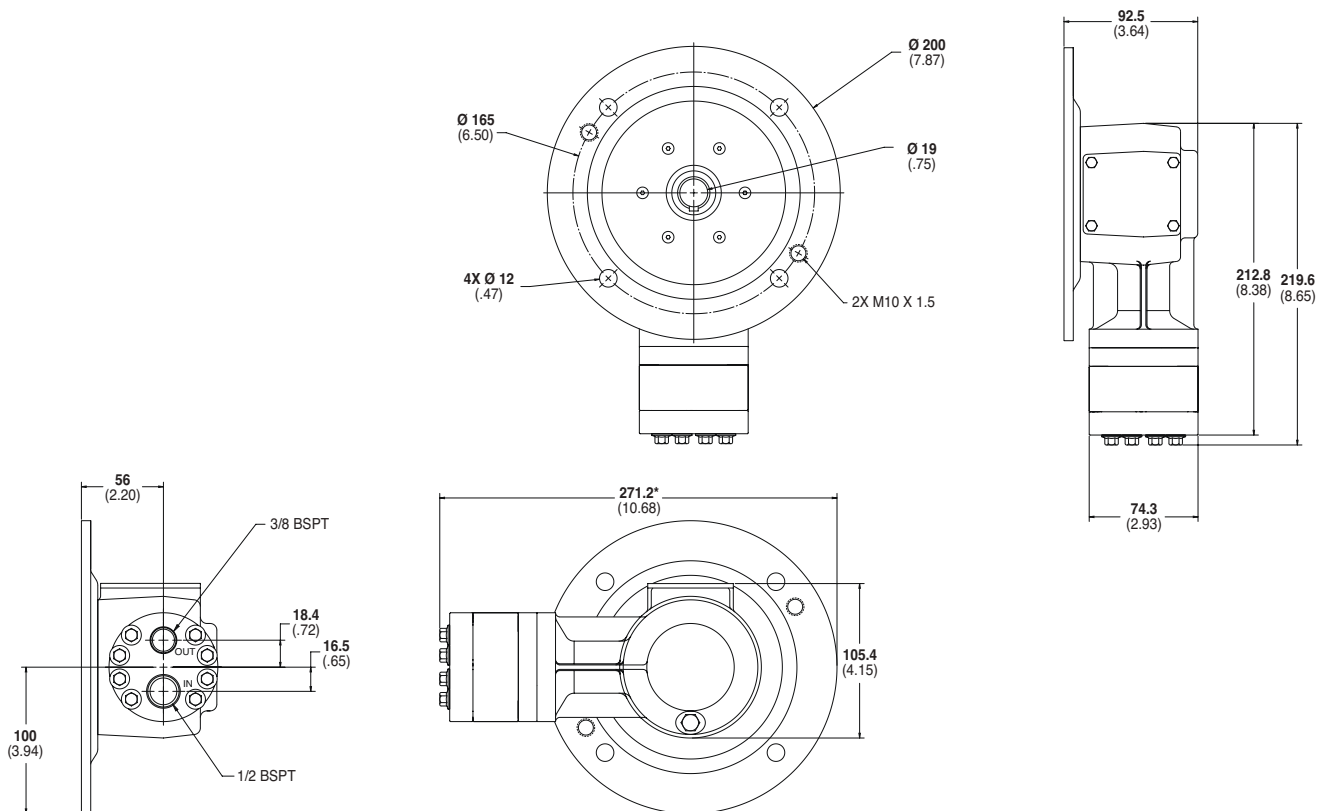

G20 Models with Non-Metallic Pump Head mm (Inches)

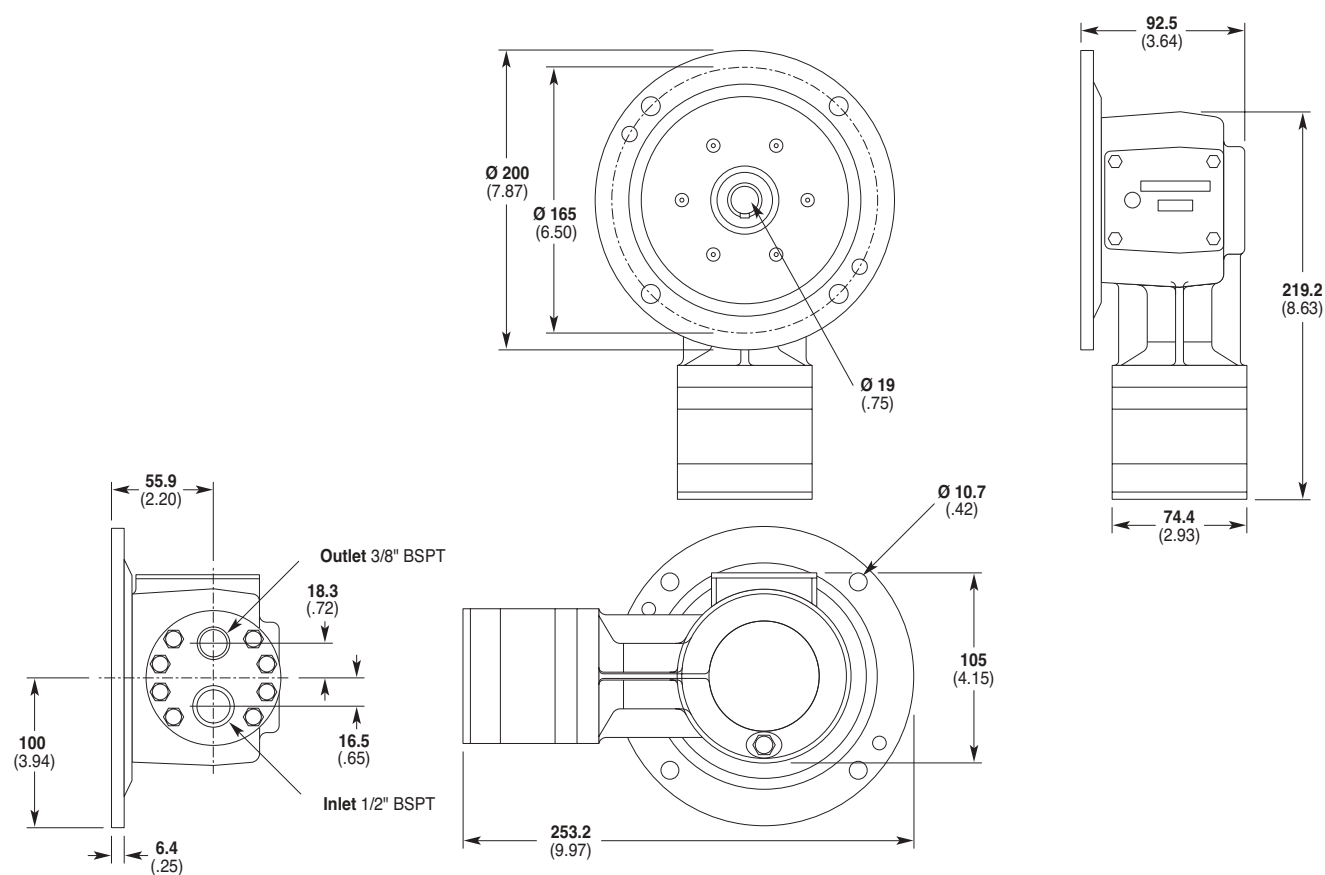

Note: Dimensions are for reference only. Contact factory for certified drawings.

G22 Models with Metallic Pump Head mm (Inches)

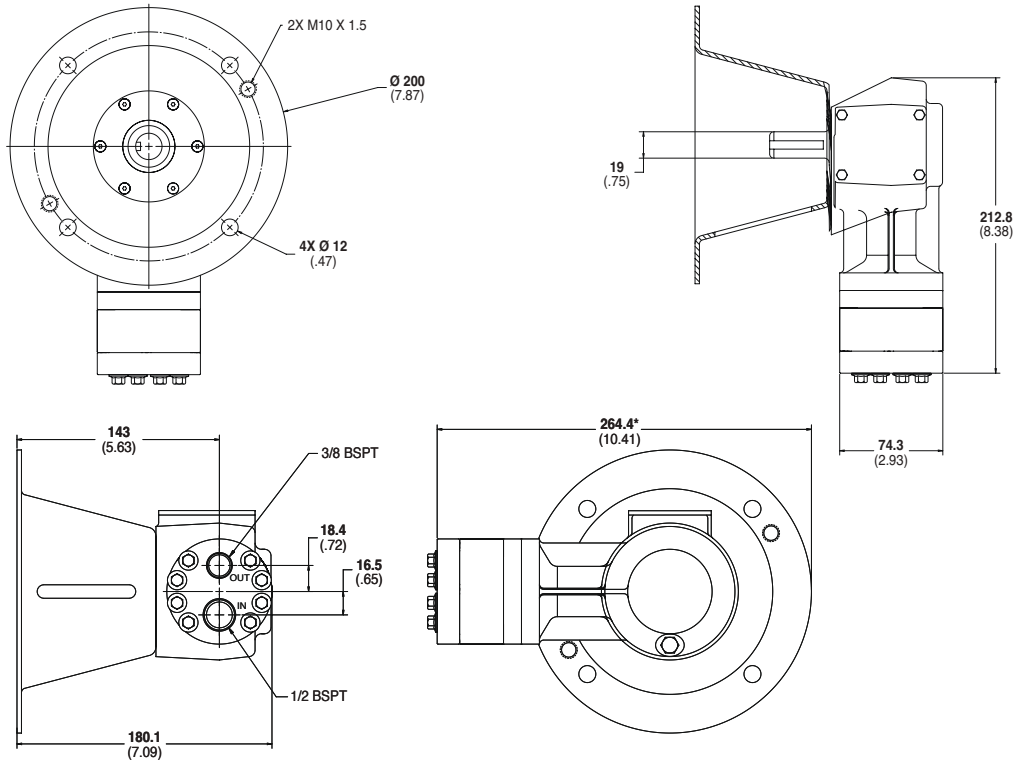

G22 Models with Non-Metallic Pump Head mm (Inches)

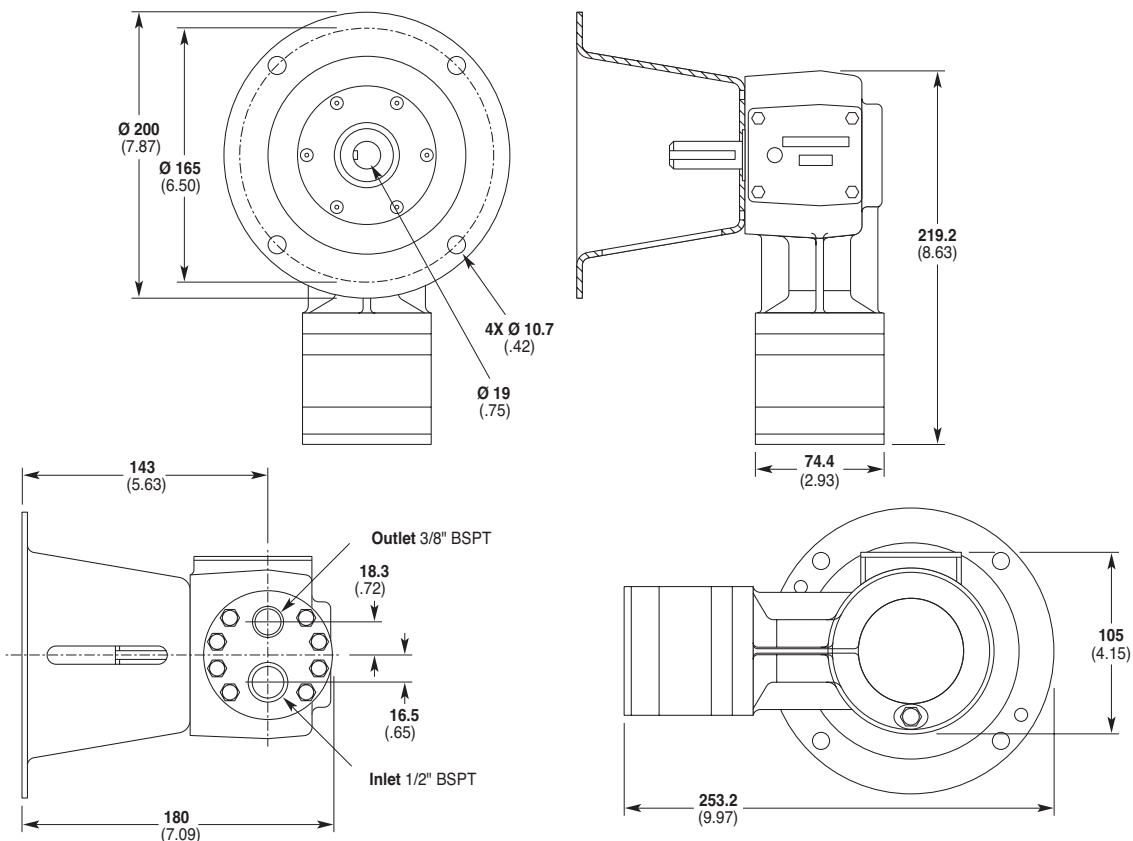

Drawings shows assembly with motor adapter A04-006-1200

Note: Dimensions are for reference only. Contact factory for certified drawings.

Pump/Motor Adapter mm (Inches)

Part Number: A04-006-1200

Must be ordered separately for G22 models (optional for G21 models) for use with IEC 80 and 90 frame motors, B5 flange.

NEMA adaptor available - consult factory.

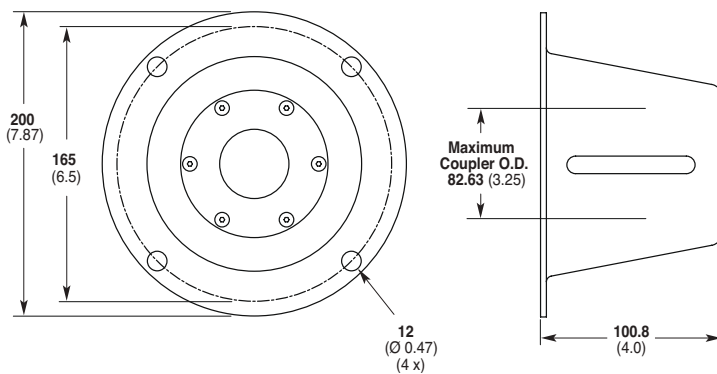

Valve Selection

A Hydra-Cell G20, G21 or G22 pumping system uses a **C46 Pressure Regulating Valve**.



G20 Pro Series | Options

Contact Wanner International for:

- Motors, bases, couplings and other pump accessories
- Hydra-Oil selection and specification information
- Design considerations, installation guidelines, and other technical assistance in pump selection
- Process liquid end built with NACE and 3.1 traceable material certification



G20 Close-coupled with Polypropylene pump head



G22 Flexible-coupled with Stainless Steel pump head

Ordering Information

A complete G20 Series Model Number contains 12 digits including 9 customer-specified design and materials options, for example: G20GAPGHFEGG.

1	2	3	4	5	6	7	8	9	10	11	12
G	2		X	D							

Digit	Order Code	Description
1-3		Pump Configuration
	G20	Suitable for close coupling to IEC 80 motor (BSPT Ports)
	G22	For use with pump/motor adaptor (BSPT Ports)* *Pump/motor adaptors ordered separately. See previous page.
4		Hydraulic End Cam
	X	Max 3.19 l/min (0.87 USgpm) @ 1450 rpm
5		Pump Head Version
	D	BSPT Ports (for all G20 & G22 pumps) <i>See lower right for ATEX Certification Kit Options.</i>
6		Pump Head Material
	B	Brass
	M	PVDF
	P	Polypropylene
	S	316L Stainless Steel
	T	Hastelloy C
7		Diaphragm & O-ring Material
	A	Aflas diaphragm / PTFE o-ring
	E	EPDM (requires EPDM-compatible oil - Digit 12 oil code J)
	G	FKM
	J	PTFE
	P	Neoprene
	T	Buna-N
8		Valve Seat Material
	C	Ceramic
	D	Tungsten Carbide
	H	17-4 Stainless Steel
	S	316L Stainless Steel
	T	Hastelloy C

Digit	Order Code	Description
9		Valve Material
	C	Ceramic
	D	Tungsten Carbide
	F	17-4 Stainless Steel
	N	Nitronic 50
	T	Hastelloy C
10		Valve Springs
	E	Elgiloy
	T	Hastelloy C
11		Valve Spring Retainers
	C	Celcon
	H	17-7 Stainless Steel
	M	PVDF
	P	Polypropylene
	T	Hastelloy C
	Y	Nylon
12		Hydra-Oil
	G	5W30 cold-temp severe-duty synthetic oil
	J	20-wt EPDM-compatible oil
	K	Food-contact oil



ATEX Certification Kit Options

As a separate line on your order, please add the required ATEX Certification Kit Option.

- ATEX 2014/34/EU Certified, Category 2, Zone 1
- ATEX 2014/34/EU Certified, Category 3, Zone 2





- All options include Certificate, Oil Level Monitor or Sight Glass, Earth Stud & Secondary ATEX Label.
- Extra oil is required to fill the oil bowl during installation of ATEX pumps. This oil is not included and must be ordered separately.
- ATEX is not available with non-metallic pump heads.

Partners in over 70 countries



WANNER™
Global Sales and Technical Support



Americas

-  Minneapolis, Minnesota USA
-  Wichita Falls, Texas USA
-  São Paulo, Brazil
-  Buenos Aires, Argentina





EMEA | Australia

-  Hampshire, United Kingdom
-  Cairo, Egypt
-  Düsseldorf, Germany
-  Lyon, France

Asia | Pacific

-  Kowloon, Hong Kong
-  Shanghai, China
-  Jakarta, Indonesia

India

-  Mumbai, India
-  New Delhi
-  Bangalore
-  Gujarat

Wanner worldwide

GLOBAL SALES & TECHNICAL SUPPORT

WANNER ENGINEERING, INC.

WORLD HEADQUARTERS & MANUFACTURING

Minneapolis, Minnesota USA
t: 612-332-5681
e: sales@wannereng.com
Hydra-Cell.com

REGIONAL OFFICE

Wichita Falls, Texas USA
t: 940-322-7111
e: sales@wannereng.com

LATIN AMERICAN OFFICE

São Paulo, Brazil
t: +55 (11) 99582-1969
e: mmagoni@wannereng.com
Hydra-Cell-Pumps.com.br

WANNER INTERNATIONAL, LTD.

UNITED KINGDOM

Church Crookham, Hampshire UK
t: +44 (0) 1252 816847
e: support@wannerint.com
Hydra-Cell.co.uk

WANNER PUMPS, LTD.

Kowloon, HONG KONG
t: +852 3428 6534
e: sales@wannerpumps.com
WannerPumps.com

Shanghai, CHINA
t: +86-21-6876 3700
e: sales@wannerpumps.com
WannerPumps.com

WANNER INDIA PVT. LTD.

Mumbai, INDIA
t: +91 (22) 22044766
e: support@wannerindia.com
WannerIndia.com



OFFICIAL UK DISTRIBUTOR

Michael Smith Engineers Limited
Web: www.michael-smith-engineers.co.uk
Email: info@michael-smith-engineers.co.uk
Freephone: 0800 316 7891