

P500 Series Electronic Precision Metering Pumps

Maximum Flow Rate: 1243 L/hr

Maximum Pressure: 172 bar for Metallic Pump Heads

API 675

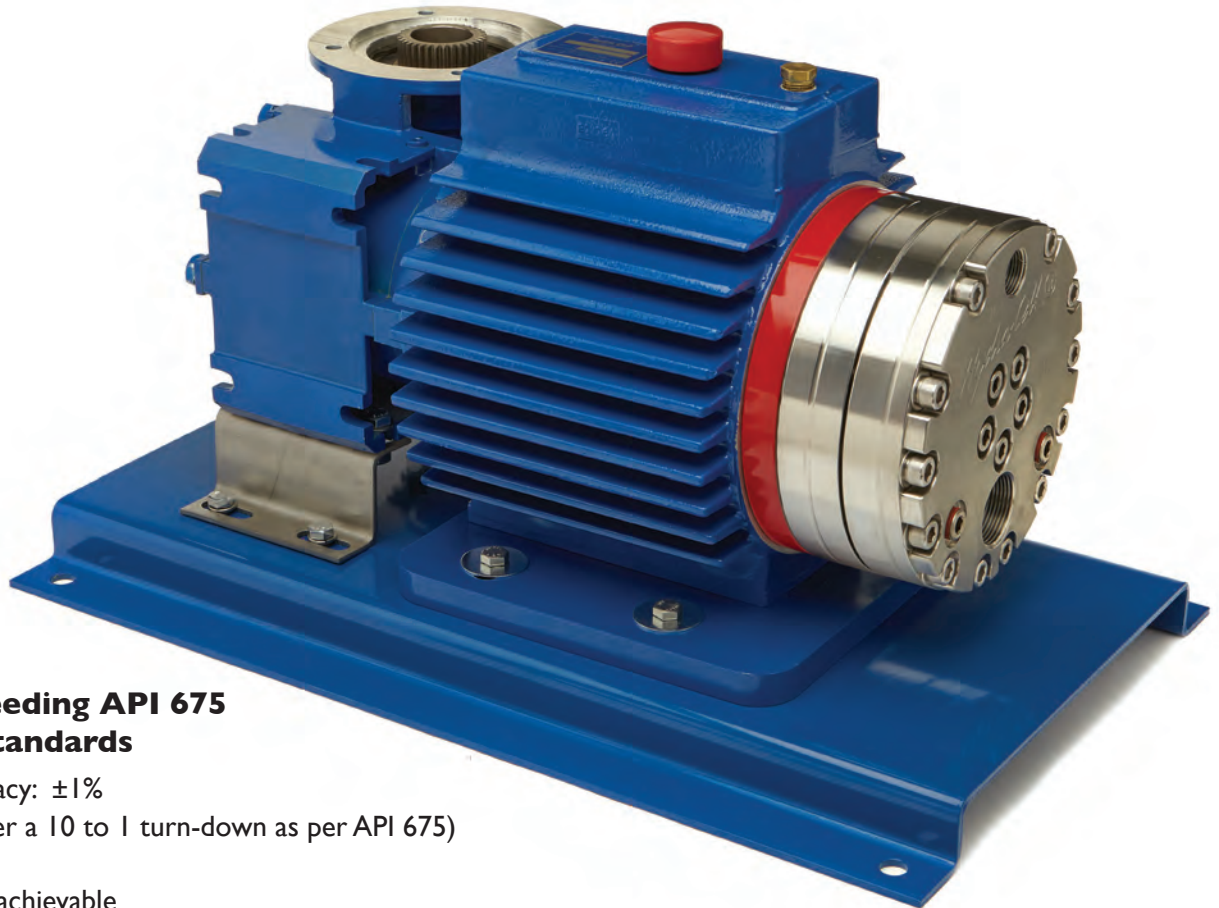

Meeting & Exceeding API 675 Performance Standards

- Steady State Accuracy: $\pm 1\%$
- Linearity: $\pm 3\%$ (over a 10 to 1 turn-down as per API 675)
- Repeatability: $\pm 3\%$
- Infinite turn-down achievable

Unique Multiple Diaphragm Design for Linear, Pulse-free Flow

Hydra-Cell Metering Solutions P500 pumps feature five diaphragms in one pump head. This unique design enables Hydra-Cell to provide virtually “pulse-free” flow without the need to buy expensive pulsation dampeners.

- Minimises pipe strain and other maintenance; enhances operator safety
- Reduces acceleration/friction losses in the suction line
- Provides accurate metering with linear, constant flow

Hydra-Cell P500 Pressure Trace

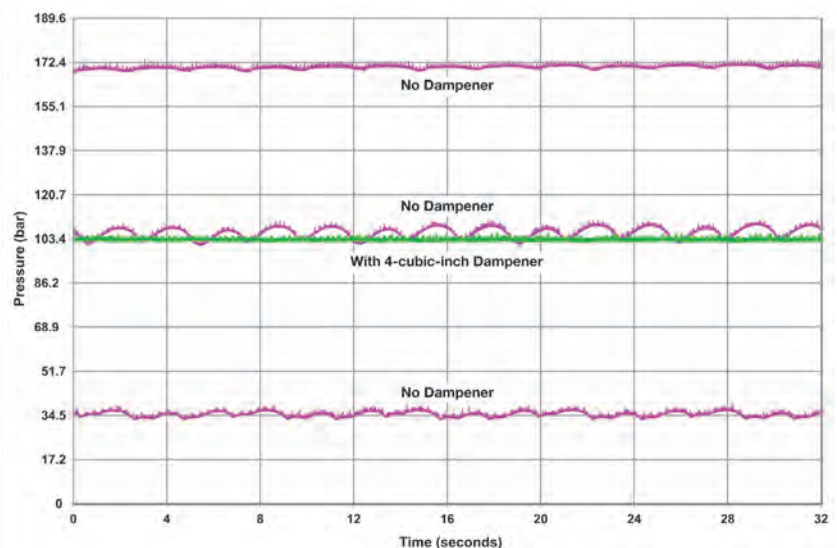

Hydra-Cell can eliminate the need for expensive pulsation dampeners because, as the graph shows, it provides virtually pulse-less flow.

Performance - Flow Capacities and Pressure Ratings

For Synchronous Speed, Self-cooled Motors

L/hr Maximum Flow at Designated Pressure

L/hr Metallic Pump Heads Only				Pump RPM	Gear Ratio	Motor RPM
7 Bar	34 Bar	103 Bar	172 Bar			
55.1	53.5	49.7	45.6	25	60:1	1500
66.2	64.4	60.3	55.8	30	50:1	
83.2	81.2	76.3	71.5	37.5	40:1	
111.3	108.7	102.9	97.2	50	30:1	
133.7	130.8	124.2	117.7	60	25:1	
167.3	163.9	156.1	148.5	75	20:1	
223.3	219.1	209.3	199.8	100	15:1	
335.3	329.5	315.7	302.4	150	10:1	
447.3	439.8	422.0	405.1	200	7.5:1	
671.4	660.1	634.8	N/A	300	5:1	
895.4	881.3	N/A	N/A	400	7.5:1	3000
1343.5	1322.7	N/A	N/A	600	5:1	

Notes:

1. The motor kW are based on ambient temperature conditions up to 40°C. For ambient temperatures above 40°C, please contact Wanner International.
2. Capacity data is shown for pumps with elastomeric diaphragms. Contact factory for performance characteristics of pumps with PTFE diaphragms.
3. Contact factory for performance specifications.
4. Based on using IE2 motors.
5. Maximum continuous motor speed is 1800 rpm at full pressure.
6. For intermittent or reduced pressure duties, please contact Wanner International.

Required Motor kW

0.18	0.37	0.55	0.75	1.1
1.5	2.2	4.0		

For 10:1 Turndown, Self-cooled Motors

L/hr Maximum Flow at Designated Pressure

L/hr Metallic Pump Heads Only				Pump RPM	Gear Ratio	Motor RPM
7 Bar	34 Bar	103 Bar	172 Bar			
55.1	53.5	49.7	45.6	25	60:1	1500
66.2	64.4	60.3	55.8	30	50:1	
83.2	81.2	76.3	71.5	37.5	40:1	
111.3	108.7	102.9	97.2	50	30:1	
133.7	130.8	124.2	117.7	60	25:1	
167.3	163.9	156.1	148.5	75	20:1	
223.3	219.1	209.3	199.8	100	15:1	
335.3	329.5	315.7	N/A	150	10:1	
447.3	439.8	422.0	N/A	200	7.5:1	
671.4	660.1	N/A	N/A	300	5:1	
895.4	N/A	N/A	N/A	400	7.5:1	3000
1343.5	N/A	N/A	N/A	600	5:1	

Notes:

1. The motor kW are based on ambient temperature conditions up to 25°C. For ambient temperatures above 25°C, Force-cooled Motors may be required. Please contact Wanner International.
2. Capacity data is shown for pumps with elastomeric diaphragms. Contact factory for performance characteristics of pumps with PTFE diaphragms.
3. Contact factory for performance specifications.
4. Based on using IE2 motors.
5. Maximum continuous motor speed is 1800 rpm at full pressure.
6. For intermittent or reduced pressure duties, please contact Wanner International.

See Page 6 for **Electronic Flow Rate Controller**.

Required Motor kW

0.37	0.55	0.75	1.1	1.5	2.2
3.0	4.0				

P500 Series

Specifications

Diaphragms per Liquid End	5
Flow Control	Electronic variable speed drive
Maximum Discharge Pressure	
Metallic Heads:	172 bar
Maximum Inlet Pressure	34 bar
Maximum Liquid Operating Temperature	
Metallic Heads:	121 °C - Consult factory for correct component selection for temperatures greater 71 °C.
Maximum Solids Size	500 microns
Inlet Port	1-1/4 inch BSPT
Discharge Port	3/4 inch BSPT
Shaft Rotation	Reverse (bi-directional)
Oil Capacity	2.1 litres
Weight (less motor)	
Metallic Heads:	88.5 kg
Dimensions (less motor)	
Metallic Heads:	368.3 mm W x 609.6 mm D x 353.1 mm H

Representative Drawings (mm)

Metallic Pump Heads

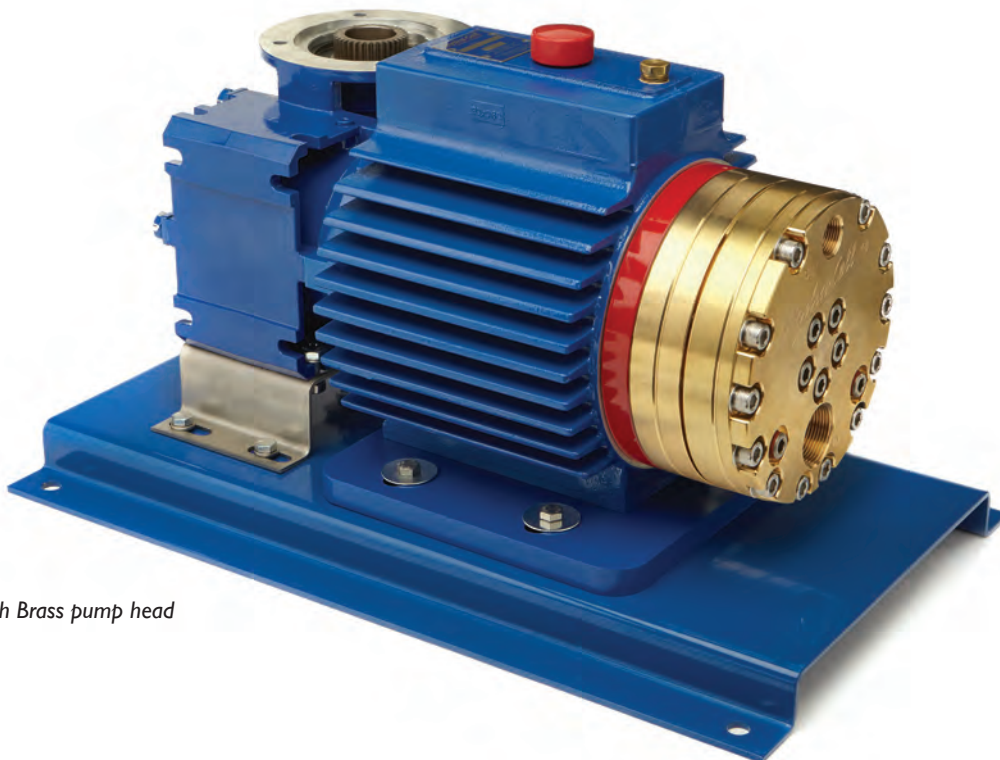
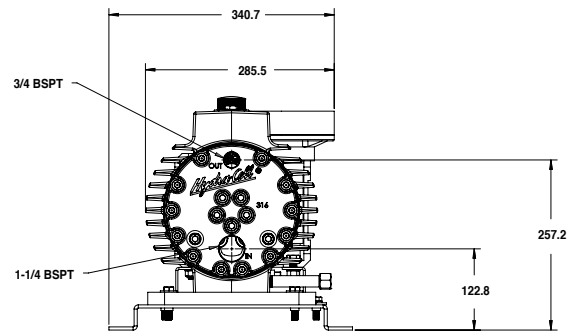
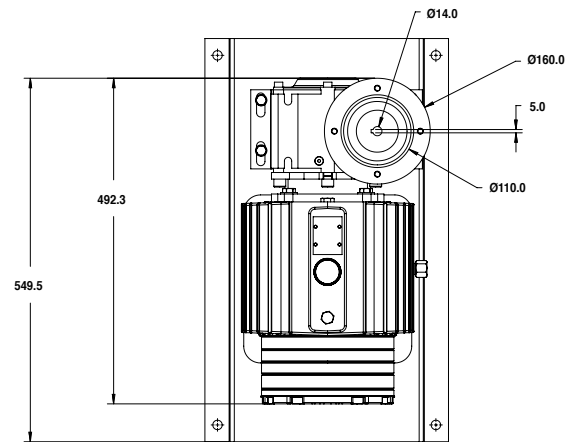

P500 with Brass pump head

Pump Ordering Information

A complete pump order number contains 13 digits based on the specified pump materials listed below. Contact your Hydra-Cell sales representative for accompanying motor drive options.

1	2	3	4	5	6	7	8	9	10	11	12	13
P	5	0	0									H

Pump Model Size (Digits 1-4)

P500 For all P500 Pumps (Non Kel-Cell)

Pump Version (Digit 5)

N NPT Ports (NEMA motors only)
M BSPT Ports (IEC motors only)

Pump Head / Retainer Material (Digit 6)

B Brass / Hastelloy C
S 316L Stainless Steel / Hastelloy C
T Hastelloy C / Hastelloy C

Diaphragm & O-ring Material / Oil (Digit 7)

A Atlas / PTFE o-ring (Synthetic oil)
G FKM (Standard oil)
S FKM (Food-contact oil)
X FKM (Synthetic oil)
T Buna-N (Standard oil)
F Buna-N (Food-contact oil)
Y Buna-N (Synthetic oil)

Check Valve Material (Digits 8-9) (Valve Spring / Valve Seat / Valve)

SS Elgiloy / Nitronic 50 / Nitronic 50
TT Hastelloy C / Hastelloy C / Hastelloy C
SD Elgiloy / Tungsten Carbide / Tungsten Carbide
TD Hastelloy C / Tungsten Carbide / Tungsten Carbide

Gearbox Ratio (Digits 10-12) IEC Motors

A60	60:1	(71 B5 Motor Frame)
B60	60:1	(80 B5 Motor Frame)
A50	50:1	(71 B5 Motor Frame)
B50	50:1	(80 B5 Motor Frame)
A40	40:1	(71 B5 Motor Frame)
B40	40:1	(80 B5 Motor Frame)
A30	30:1	(71 B5 Motor Frame)
B30	30:1	(80 B5 Motor Frame)
B25	25:1	(80 B5 Motor Frame)
C25	25:1	(90 B5 Motor Frame)
B20	20:1	(80 B5 Motor Frame)
C20	20:1	(90 B5 Motor Frame)
B15	15:1	(80 B5 Motor Frame)
C15	15:1	(90 B5 Motor Frame)
B10	10:1	(80 B5 Motor Frame)
C10	10:1	(90 B5 Motor Frame)
D10	10:1	(100/112 B14 Motor Frame)
B07	7.5:1	(80 B5 Motor Frame)
C07	7.5:1	(90 B5 Motor Frame)
D07	7.5:1	(100/112 B14 Motor Frame)
B05	5:1	(80 B5 Motor Frame)
C05	5:1	(90 B5 Motor Frame)
D05	5:1	(100/112 B14 Motor Frame)

Note: These are Wanner standard options. Other flange sizes are available upon request.

Base Plate (Digit 13)

H Carbon Steel (Epoxy painted) size 75

Notes:

1. Please consult factory for rpm below 6.
2. Constant torque drives are required to meet API 675 performance standards.
3. Ensure that the motor chosen is capable of delivering the torque and power required over the full range of adjustment. (Consult factory for values.)
4. IEC motor size has been calculated assuming IE2 performance as defined by IEC 60034-30.

Calibration Cylinders

Port Size	Cylinder Size (mL)	Cylinder Capacity (L/h)	Maximum Shaft (rpm)	Part Number BSPT Ports	Dimensions - mm	
					Height	Diameter
PVC Cylinders						
1/2"	200	24	75	111-001-B	482.6	38.1
3/4"	1000	120	300	111-003-B	558.8	63.5
1"	2000	240	600	111-004-B	508.0	94.0
2"	10000	1200	--	111-006-B	635.0	176.5.0
Glass Cylinders						
1/4"	30	3.6	36	111-010-B	355.6	35.6
1/2"	200	24	75	111-011-B	533.4	63.5
3/4"	1000	120	300	111-013-B	685.8	88.9
1"	2000	240	600	111-014-B	685.8	127.0

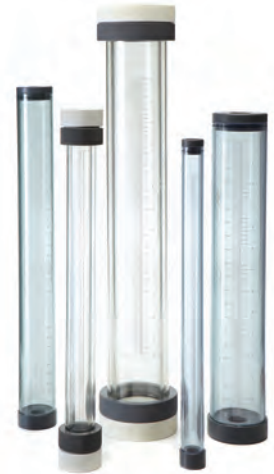

Back Pressure Valves

Port Size	Maximum Flow (L/h) Pulsating	Wetted* Materials	Pressure Adjustment Range (bar)	Maximum Temp (°C)	Part Number (BSPT Ports)
3/4" (DN 20)	1135	Polypropylene	0.7 - 10.3	90	111-341-B
	1135	PVDF	0.7 - 10.3	90	111-343-B
	1135	316 SST	0.7 - 10.3	149	111-346-B
	1135	Hastelloy C	0.7 - 10.3	149	111-350-B

* Diaphragm material is PTFE on all models. Other materials available on request.



Pressure Relief Valves

Port Size	Maximum Flow (L/h) Pulsating	Wetted* Materials	Pressure Adjustment Range (bar)	Maximum Temp (°C)	Part Number (BSPT Ports)
3/4" StdFlo (DN 20)	1135	Polypropylene	0.7 - 10.3	90	111-541-B
	1135	PVDF	0.7 - 10.3	90	111-543-B
	1135	316 SST	0.7 - 10.3	149	111-546-B
	1135	Hastelloy C	0.7 - 10.3	149	111-550-B
3/4" HiFlo (DN 20)	2271	Polypropylene	0.7 - 10.3	90	111-641-B
	2271	PVDF	0.7 - 10.3	90	111-643-B
	2271	316 SST	0.7 - 10.3	149	111-646-B
	2271	Hastelloy C	0.7 - 10.3	149	111-650-B
3/4" High Pressure (DN 20)	4542	316 SST	24 - 172	149	111-746-B
	4542	Hastelloy C	24 - 172	149	111-750-B

* Diaphragm material is PTFE on all models. Other materials available on request.

Metering and Dosing Control Options

Electronic Flow Rate Adjustment for Local Control

- Force-cooled Drives supplied as standard
- IP66 Standard
- Various flow rate adjustments options including:
 1. On-board potentiometer(s)
 2. On-board key-pad controller with flow rate display
 3. Removable, hand-held key-pad controller for authorised personnel only
 4. Use the 10:1 Turndown table on Page 2 to select the correct motor kW for ambient temperatures up to 25°C

Maximum Flow at Designated Pressure (see table on Page 2)



On-board keypad control



Hand-held keypad control

Control Freak™ for Sophisticated Local Control

- Option available to control up to 6 x Hydra-Cell pumps with one Hydra-Cell “Control Freak”
- Multiple Variable Frequency Drive (VFD) options
- Enables programming for flow rate or totalisation
- Allows up to 10 x separate batch sequences
- Built-in calibration mode



P500 Series

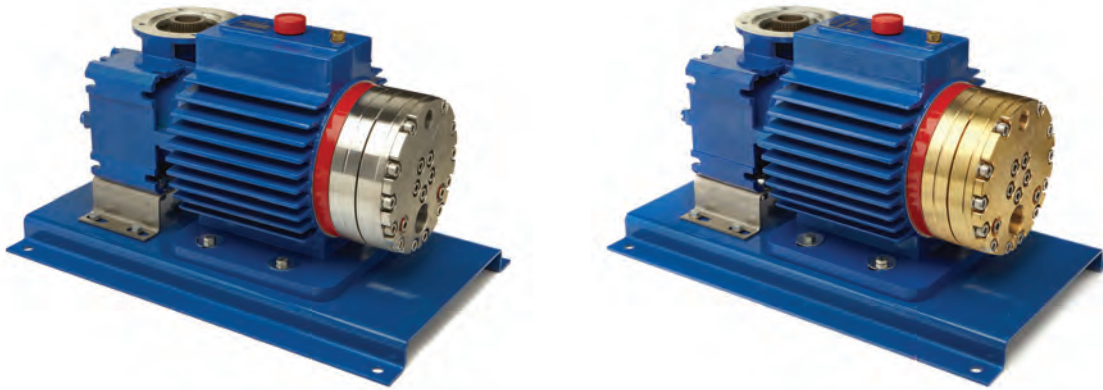

WANNER

Hydra-Cell[®]
Partners in over 70 Countries

Standards Compliance



- API 675 performance testing, both witnessed and non-witnessed available. (Consult your local Wanner office for further details.)

 **Wanner International Ltd.**

**WANNER INTERNATIONAL
UNITED KINGDOM**

8 & 9 Fleet Business Park
Sandy Lane • Church Crookham
Hampshire UK GU52 8BF
t +44(0) 252 816847
e: sales@wannerint.com

 **Wanner Engineering, Inc.**

**WANNER ENGINEERING
WORLD HEADQUARTERS &
MANUFACTURING
Minneapolis USA**

t+1 612-332-5681
e: sales@wannereng.com

**REGIONAL OFFICE
Texas USA**

t+1 940-322-7111
e: sales@wannereng.com

LATIN AMERICAN OFFICE

São Paulo, Brazil
t +55 (11) 99582-1969
e: sales@wannereng.com

 **Wanner Pumps Ltd.**

**WANNER PUMPS
Kowloon HONG KONG**
t +852 3428 6634
e: sales@wannerpumps.com

Shanghai CHINA

t +88 21 6876 3700
e: sales@wannerpumps.com

WANNER

Hydra-Cell[®]
Seal-less Pumping Technology

www.hydra-cell.co.uk