



**I Application**

The Aspir pump is a sanitary, side-channel, self-priming pump suitable for use in the food-processing, pharmaceutical and chemical industries. It is specially designed for pumping materials containing air or gas, and it can also be used for negative suction with prior priming as well as with filtration equipment. It can be used with wine, oil, syrups, volatile products such as alcohol, acetone and other solvents, or with products at temperatures close to boiling point. However, the main use of this pump is for CIP return.

**I Operating principle**

The impeller is housed between the inlet body and the venturi casing and it rotates in conjunction with the pump shaft. This arrangement, together with the rotation of the impeller and the arrangement of the side channel, creates a negative pressure inside the inlet body, which generates the suction force of the pump. At the same time, the fluid receives energy in the form of kinetic energy and pressure energy, and this impels it through the impeller casing.

**I Design and features**

- Cold-formed pump casing.
- Stainless steel investment casting inletbody and venturi.
- Investment casting star-shaped floating impeller.
- External mechanical seal prevents contact between the springs and the pumped product.
- Very robust stainless steel cast lantern.
- Stainless steel support.

**Mechanical seal**



**I Materials**

Parts in contact with pumped product	AISI 316
Other parts	AISI 304
Gaskets	EPDM according to FDA 177.2600
Mechanical seal	C/SiC/EPDM
Surface finish	Electropolished

**I Options**

- Mechanical seal in SiC/SiC.
- Gaskets in FPM and PTFE.
- Drain port.
- Connections: Clamp, SMS, RJT., etc.
- Bypass.



**I Technical specifications**

Maximum flow	56 m <sup>3</sup> /h	247 GPM
Maximum head	9 bar	130 PSI
Maximum suction pressure	40 mcl	58 PSI
Maximum suction height	7 m	10 PSI
Maximum working temperature	120 °C	248 °F
Maximum speed	1750 rpm	

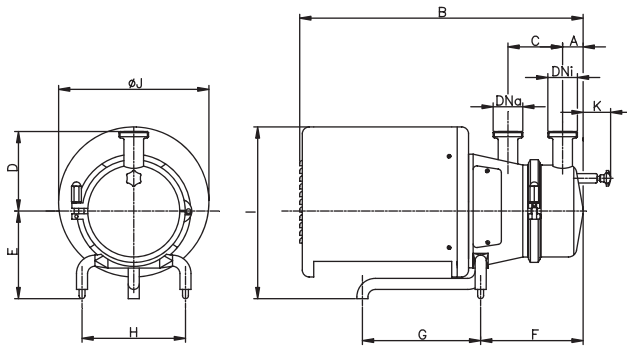
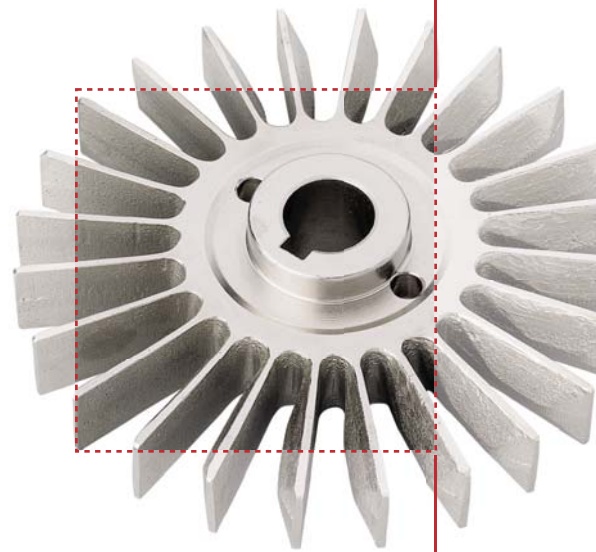

TYPE	Motor [kW]	DNa	DNi	A	B	C	D	E	F	G	H	I	ØJ	K
A-50	0.75	32 1½"	32 1½"	37	490	86	125	165	158	235	205	325	270	57
	2.2													
A-80	3	40 1½"	40 1½"	45	625	120	175	190	225	275	205	375	330	65
	4													
	5.5													
A-150	4	50 2"	50 2"	45	625	120	175	190	225	275	205	375	330	62
	5.5													
A-200	11	65 3"	65 3"	60	947	150	225	280	313	355	320	555	465	59
	15													

Dimensions for pumps with DIN 11851 connections.

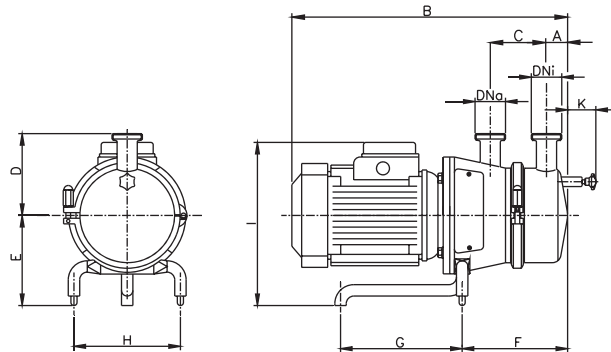

TYPE	Motor [kW]	DNa	DNi	A	B	C	D	E	F	G	H	I	K
A-50	0.75	32 1½"	32 1½"	37	420	86	125	165	158	235	205	275	57
	2.2												
A-80	3	40 1½"	40 1½"	45	550	120	175	190	225	275	205	326	65
	4				555							336	
	5.5												
A-150	4	50 2"	50 2"	45	555	120	175	190	225	275	205	336	62
	5.5												
A-200	11	65 3"	65 3"	60	825	150	225	280	313	355	320	524	59
	15				870								

Dimensions for pumps with DIN 11851 connections.



The information contained in this brochure is for guidance only. We reserve the right to modify any material or feature without notice in advance. For further information, please, consult our web site. [www.inoxpa.com](http://www.inoxpa.com)





# OFFICIAL DISTRIBUTORS FOR:

