

Reglo ICC

Independent Channel Control Peristaltic Pump

By providing individually addressable control of each fluidic channel, the new Ismatec® Reglo ICC eliminates the clutter of multiple pumps on the bench top as well as allowing you, the scientist, to solve your application complexity in a single pump. Long hailed in Europe as the gold standard of Swiss precision, Ismatec drives will now power four channels, each independently programmable from the pump or the computer.

Volumetric Dispense

- ▶ Continuous pumping or precision dispensing
- ▶ Flexibility of bi-directional flow in each channel
- ▶ Easy-to-use tubing cassettes allow quick changeovers
- ▶ Independent channel calibration minimizes the tube to tube differences resulting in the best calibration accuracy possible in a multichannel peristaltic pump
- ▶ New easy-to-use USB interface makes connections quickly

Technical Specifications

- ▶ Available with four channels, each with independent functionality
- ▶ Flow range per channel: 0.0002 to 35 mL/min
- ▶ PC control or keypad control



ISM4408

Pump Specifications

Motor Type	Stepper Motor (1/channel)
Speed Range	0.1–100 RPM
Speed Setting	RPM (Resolution = 0.01 RPM)
Flow Rate Range	0.0002–35 mL/min/channel (tubing dependent)
Number of Channels	2–4
Number of Rollers	8 Ertalyte® rollers standard; 6 and 12-roller options also available
Cassettes	MS/CA Click'n'Go (POM-C; alternatives available)
Dimensions (HxWxD)	6.7" (170 mm) x 5" (125 mm) x 8.1" (205 mm)* (*=for 3-channel model)
Weight	6 lbs. (2.7 kg)
Power Consumption	30 W (Max) Main Voltage: 100–264 V AC / 50/60 Hz (Requires use of included power supply, cables)
Protection Rating	IP 30
Differential Pressure	1.0 bar / 14.5 psi (Max)

Flow Rate Range

Tubing ID (mm)	Flow Rate (mL/min per channel)	
	0.1 RPM	100 RPM
	Minimum	Maximum
0.13	0.0002	0.11
0.25	0.0005	0.41
0.51	0.0017	1.7
0.76	0.0036	3.6
1.02	0.0063	6.3
1.22	0.0088	8.8
1.52	0.013	13
1.85	0.017	17
2.54	0.027	27
3.17	0.035	35

Available Tubing Sizes

Inner Diameter Range	0.13–3.17 mm (tubing material dependent)
Wall Thickness	0.8 mm

Please note: all tubing must have stoppers with correct spacing to be used with MS/CA cassettes

Environmental Conditions

	Operational	Storage
Temperature Range	-5 °C to +40 °C (+41 °F to +104 °F)	-10 °C to +50 °C (+14 °F to +122 °F)
Relative Humidity	up to 80% (non-condensing)	up to 80% (non-condensing)

Supported Communication Protocol

Each channel can be independently controlled via the front panel, USB interface, or RS-232 interface.

Rear Panel Connections:

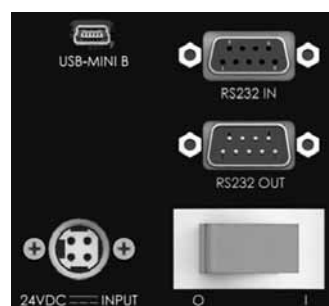

RS-232 In (DB9-female)
RS-232 Out (DB9-male)
USB 2.0, Mini-B

Operating Modes

- Flow Rate** Continuous operation at a set rate and direction
- Volume Over Time** Dispensing a desired volume over a desired time
- Volume** Dispensing a desired volume at a set flow rate
- Time Mode** Dispensing for a set time duration with a set flow rate
- Volume With Pause** Dispensing a set volume over multiple cycles with defined pause time in between
- Time With Pause** Dispensing for a set time duration over multiple cycles with defined pause time in between
- Calibration** Allows each channel to be calibrated for dispensed fluid volume accuracy

More complex routines are available through the use of the supplied software. Additionally, up to eight pumps can be connected to a computer at once, either by a USB hub or daisy chaining the RS-232 in/out connectors on the pump(s). (Note: For full functionality of each channel via RS-232 control, each pump must be directly connected to a serial interface such as Hypercom or PuTTY.) In the ICC daisy chain configuration, the pumps can either be controlled in legacy mode where all of the pump channels on an individual pump perform the same, or all of the individual channels are programmed with one channel command, similar to channels 2, and 3 (or 4).

Dimensions

- Overall Height:** 170 mm (~6.7")
- Overall Width:** 125 mm (~4.9")
- Overall Length:** 193 mm (~7.6")—2-channel
 205 mm (~8.1")—3-channel
 218 mm (~8.6")—4-channel

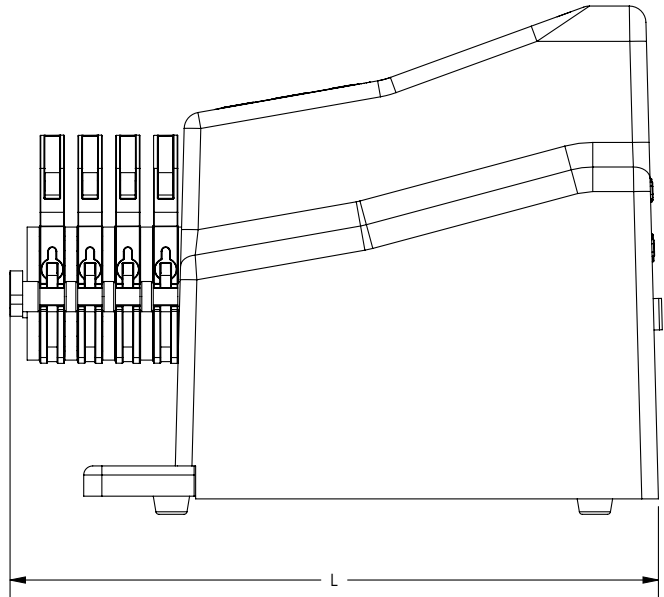
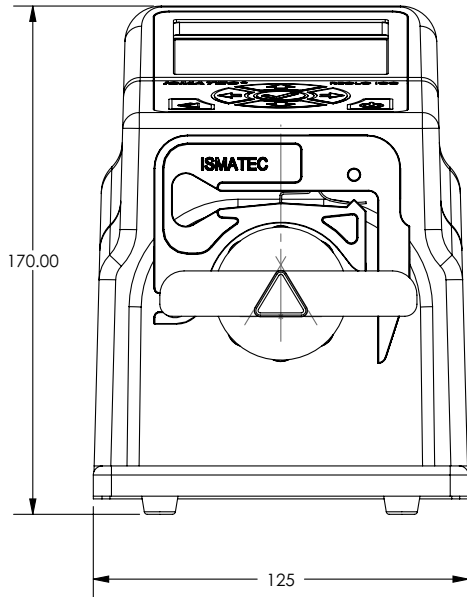

Ismatec® is a registered trademark of IDEX Health & Science LLC
 ©2013 IDEX Health & Science LLC
 IDX1767-PD/03.2013

www.idex-hs.com | North/South America +1 866 339 4653 | Europe +49 1801 808 800 | Asia +86 10 6566 9090





OFFICIAL DISTRIBUTORS FOR:

