



Model FT15S Metallic

AIR OPERATED DOUBLE DIAPHRAGM PUMPS

Specifications

Suction & Discharge Size:	1.5" x 1.5"
Porting Location:	Center
Connection Types*:	FNPT, BSPT
Air Inlet & Air Exhaust Size:	3/4" FNPT x 3/4" FNPT

*Optional ANSI/DIN/ISO flange connection upgrade available upon request

Capabilities

Maximum Flow Rate:	132 gpm (500 lpm)
Maximum Air Supply Pressure:	120 psi (8.3 bar)
Displacement Per Stroke:	0.31 gal (1.2 lit)
Minimum Air Inlet Pressure:	10 psig (0.7 bar)
Maximum Particle Size :	0.35 in (8.9 mm)
Sound Pressure:	77 dB(A)
Operating temperature:	Determined by elastomers

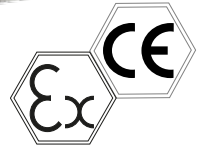

FT15 Performance

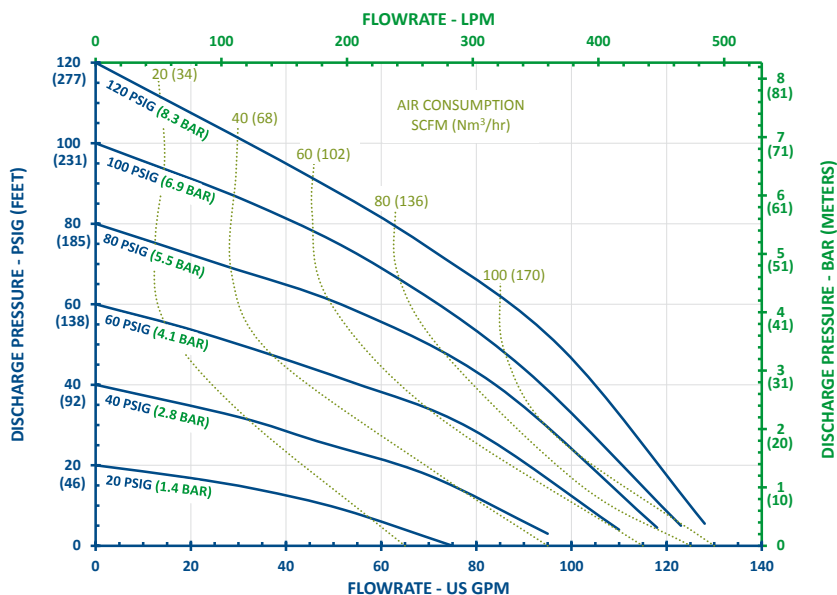

Note: Full stroke diaphragm allows performance to be equal for all elastomers.

Typical Applications

- Acids & Bases
- Plating Solutions
- Wastewater
- Paints, Inks, Solvents
- Ceramic Slip and Glaze
- Lubricants and Oils

Typical Industries

- Mining
- Paints and Coatings
- Ceramics
- Pulp and Paper
- Electroplating & Anodizing
- Wastewater
- Marine
- Chemical Manufacturing & Distribution
- OEM's

CHANGE IS IN THE AIR

Construction

Wetted Materials:	316SS
Diaphragm Materials:	Neoprene, Santoprene™, FKM, EPDM, PTFE, Buna, Hytrel®, Polyurethane
Air Valve:	GFRPP, Aluminum
Ball Materials:	Neoprene, Buna, EPDM, FKM, Santoprene™, PTFE, 316SS
Seat Materials:	Aluminum, 316SS, PTFE, Hytrel®, Buna, Neoprene, EPDM, FKM, Santoprene™, Polyurethane
O-ring Materials:	Neoprene, Buna, EPDM, FKM, PTFE, FEP/FKM

Santoprene™ is a registered trademark of Exxon Mobil Corp.
Hytrel® is a registered trademark of Dupont™

Dimensions

Maximum Height:	29-11/32 in (746 mm)
Maximum Width:	20-15/32 in (520 mm)
Maximum Depth:	12-27/32 in (326 mm)

Weight

316SS:	127 lb (57.6 kg)
--------	------------------

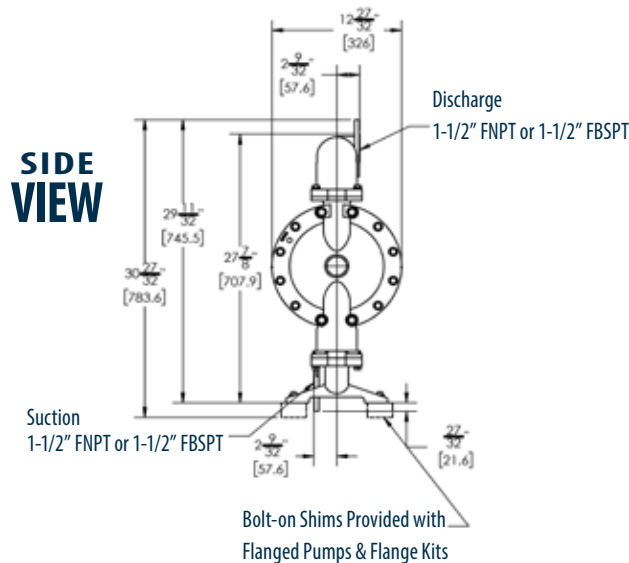
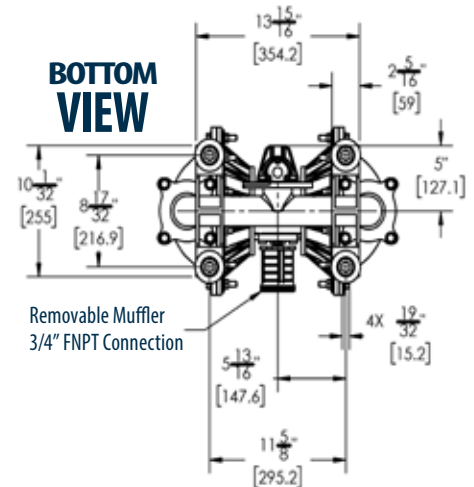
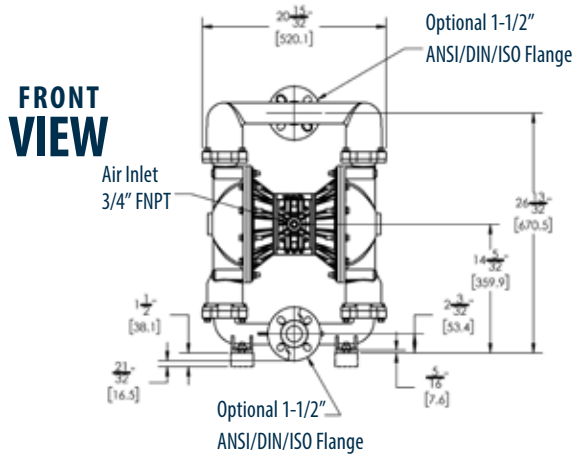

FTI AIR

921 GREENGARDEN ROAD ERIE, PA 16501
Tel: (800) 934-9384 • Fax: (814) 459-3460
www.FTIAIR.com



OFFICIAL UK DISTRIBUTOR:
Michael Smith Engineers Limited
www.michael-smith-engineers.co.uk
freephone: 0800 316 7891



Bolt-on Shims Provided with Flanged Pumps & Flange Kits