



Model FT20 Non-Metallic

AIR OPERATED DOUBLE DIAPHRAGM PUMPS

Specifications

Suction & Discharge Size:	2" x 2"
Porting Location:	End
Connection Types:	ANSI/DIN/ISO flange
Air Inlet & Air Exhaust Size:	3/4" FNPT x 3/4" FNPT

Capabilities

Maximum Flow Rate:	154 gpm (583 lpm)
Maximum Air Supply Pressure:	100 psig (6.9 bar)
Displacement Per Stroke:	0.31 gal (1.2 lit)
Minimum Air Inlet Pressure:	10 psig (0.7 bar)
Maximum Particle Size :	0.35 in (8.9 mm)
Sound Pressure:	77 dB(A)
Operating temperature:	Determined by elastomers



FT20 Performance

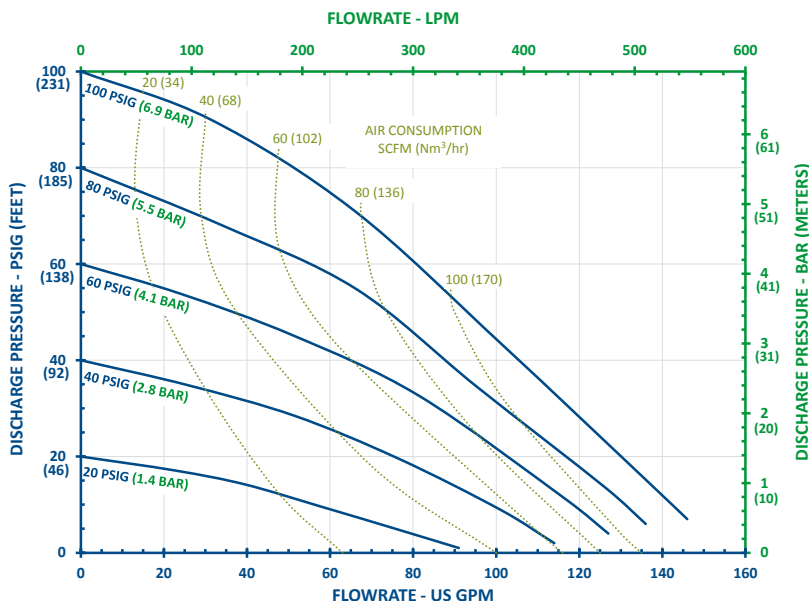

Note: Full stroke diaphragm allows performance to be equal for all elastomers.

Typical Applications

- Acids & Bases
- Plating Solutions
- Wastewater
- Paints, Inks, Solvents
- Ceramic Slip and Glaze
- Lubricants and Oils

Typical Industries

- Mining
- Paints and Coatings
- Ceramics
- Pulp and Paper
- Electroplating & Anodizing
- Wastewater
- Marine
- Chemical Manufacturing & Distribution
- OEM's

Construction

Wetted Materials:	Polypropylene, PVDF
Diaphragm Materials:	Neoprene, Santoprene™, FKM, EPDM, PTFE, Buna, Hytrel®, Polyurethane
Air Valve:	GFRPP, Aluminum
Ball Materials:	Neoprene, Buna, EPDM, FKM, Santoprene™, PTFE, 316SS
Seat Materials:	Polypropylene, PVDF
O-ring Materials:	Buna, FKM, Santoprene™, Polyurethane, FEP/FKM

Santoprene™ is a registered tradename of Exxon Mobil Corp.
Hytrel® is a registered tradename of Dupont™

Pat. <http://ftiair.com/resources/ip/>

CHANGE IS IN THE AIR

Dimensions

Maximum Height:	31-11/16 in (805 mm)
Maximum Width:	23-19/32 in (600 mm)
Maximum Depth:	12-27/32 in (326 mm)

Weight

Polypropylene:	67.0 lb (30.4 kg)
PVDF:	97.5 lb (44.2 kg)

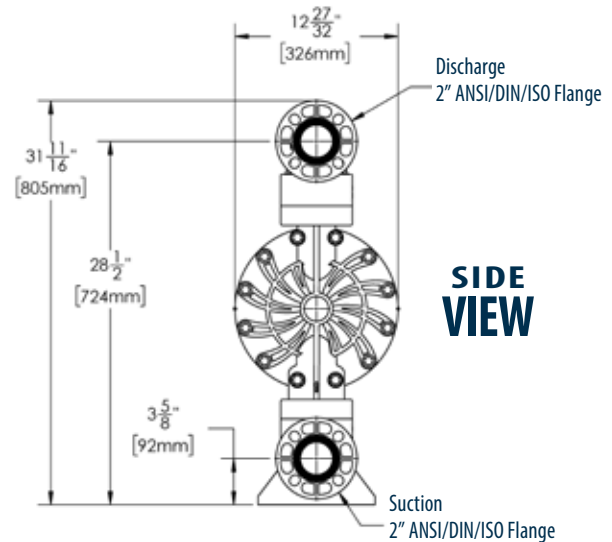
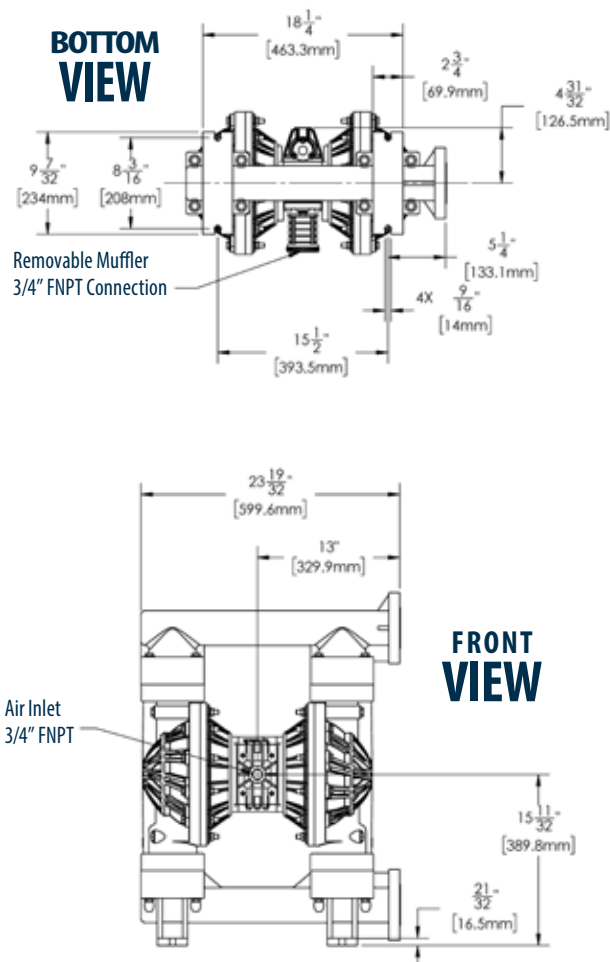

FTI AIR

921 GREENGARDEN ROAD ERIE, PA 16501
Tel: (800) 934-9384 • Fax: (814) 459-3460
www.FTIAIR.com



OFFICIAL UK DISTRIBUTOR:
Michael Smith Engineers Limited
www.michael-smith-engineers.co.uk
freephone: 0800 316 7891

